

floors is made by sewing a number of flexible strips 2, 3 to a loosely felted bat 1 of the heterogeneous fibres and cementing a thin flexible liner sheet 5 to the strips. The base 1 may be any fibrous material such as cotton, animal hair, or wood fibre. Preferably a low grade cotton is used. The strips 2, 3, sewn to the bat by rows of stitching 4, are preferably of paper. Two lines of stitching may be used to each strip, so that the

finished material may if desired be divided down the centre of the strips. The covering sheet 5 may be of paper or other material, applied to one or both sides of the base by means of an adhesive such as a solution of sodium silicate, asphalt, or glue. The adhesive also secures the stitches. the apparatus for making the material is that described in Specification 306,560, [Class 140, Waterproof &c. fabrics].

**306,579. Musgrave, J. L., and Crittall & Co., Ltd., R.** Nov. 22, 1927.

*Heating systems.* — In a heating system employing a heating-distributing circuit 11, 12, 14 and a storage circuit for heated water 5, 7, 1, 2, 3, 15, in which a mixing-chamber 6 is provided to which hot water from the storage is admitted when necessary to maintain a pre-determined temperature in the heating circuit 11, 12, 14, a thermostatically-controlled valve 13 is so placed as to control the return 14 to the mixer and the return 15 to the storage or source of heat. In Fig. 1 three storage tanks 1, 2, 3 are provided which, during the heat storage period are filled in turn. In Fig. 3, the storage tanks 1 - - 4 are mounted above the heating system and the circulation is maintained by a pump. The filling and emptying

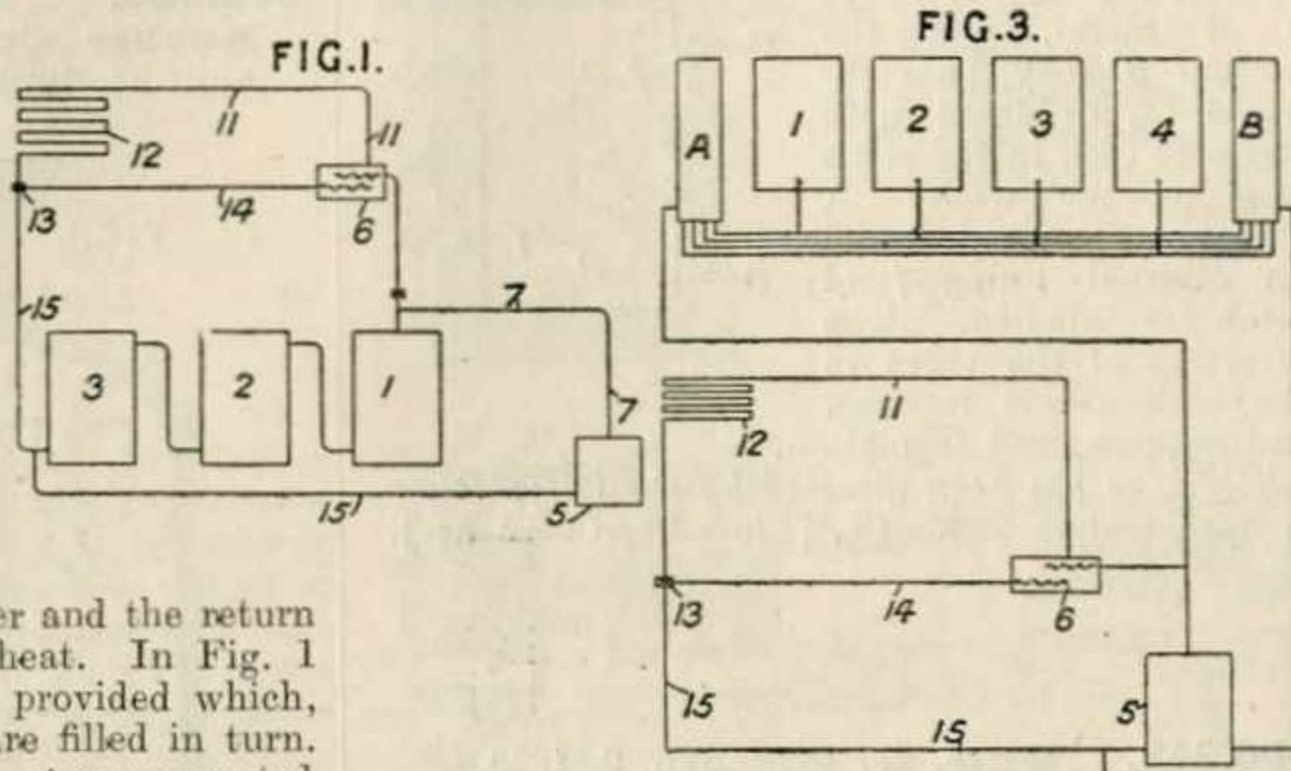

in turn as necessary of these tanks is regulated by float-controlled valves in cylinders A, B.

**306,952. Siemens - Elektrowarmoges.** Feb. 28, 1928. [Convention date].

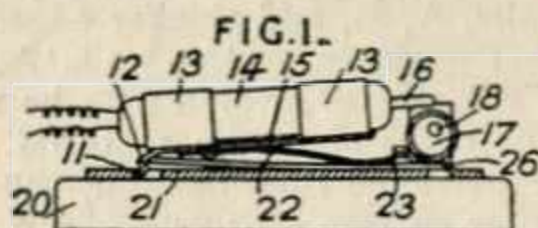

*Thermostats.*—A thermal element forming part of a switch on an electric iron, comprises an expansible copper plate 21 which co-operates with a less expansible rod 23 of stainless steel pivoted to the plate at a knife edge bearing 26.

plan, consists of strips of cork *e* which are arranged between metal strips *a, a'*. The strips are threaded over the rods *b* and the compound plate then placed under pressure to compress the cork. The tie rods *b* are bent over as at *c'* and the pressure released so that the cork expands and the ends of the rods *b* are flush with the surfaces of the plates *a, a'*. The bars *d* may be formed by slotting and then pressing out the metal strips. The compound plate may be sawn to obtain any desired size.

**307,006. Zorn Akt.-Ges., E.** March 1, 1928, [Convention date].

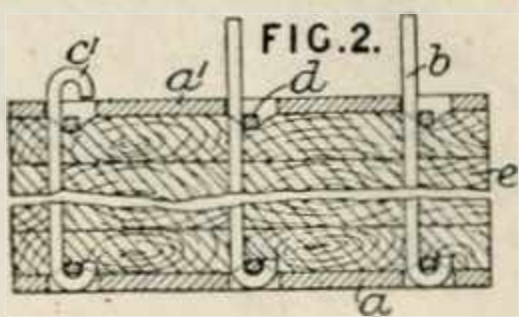

*Nonconducting coverings for sound.* — A cork foundation plate for machines, shown in sectional

**307,046. Akt.-Ges. Brown, Boveri, et Cie,** (Assignees of Osterreichische Brown, Boveri-Werke Akt.-Ges.). March 3, 1928, [Convention date].

*Thermostats.* — Automatic means adapted for regulating from a distance an electrical factor comprises a differential relay upon which the said factor and an adjustable factor of comparison cooperate to effect direct or indirect adjustment of

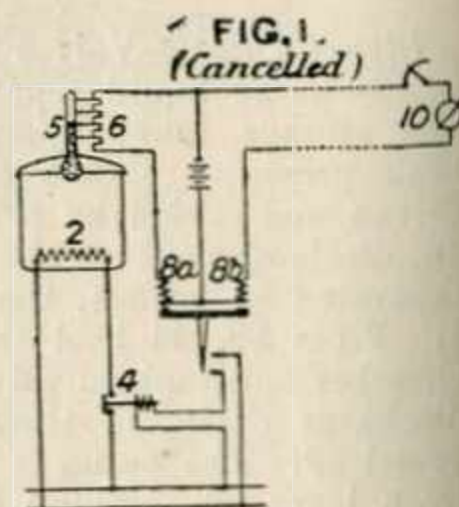

the regulating members.

The Specification as open to inspection under Sect. 91 (3) (a) describes also an arrangement for controlling the temperature of an electrically heated furnace. Fig. 1 (*Cancelled*) shows a switch 4 in the supply to a furnace heater 2 which is controlled by a differential current relay the coil 8b of which carries an adjustable comparison current and holds the switch closed until the thermometer 5 reaches a corresponding temperature, at which, by the short-circuiting of a portion or portions of the resistance 6, a balancing current is produced in the coil 8a. This subject-matter does not appear in the Specification as accepted.

**307,219. Cuthbertson, C. J.** March 16, 1928.

*Radiators; nonconducting coverings for heat.*—An insulating slab for use with a panel heating system comprises a container A of wire netting or expanded metal having a central opening B which fits over a projection C from the wall. The casing is provided with grooves E to receive the pipes or conduits F on the heating panel G. The casing is filled with slag wool or the like, and may be strengthened by wire stays I.

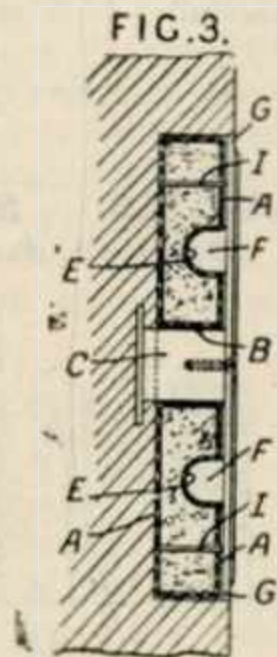

**307,376. Jackson, L. Mellersh-**,  
(Warren Webster & Co.) Dec. 5, 1927.

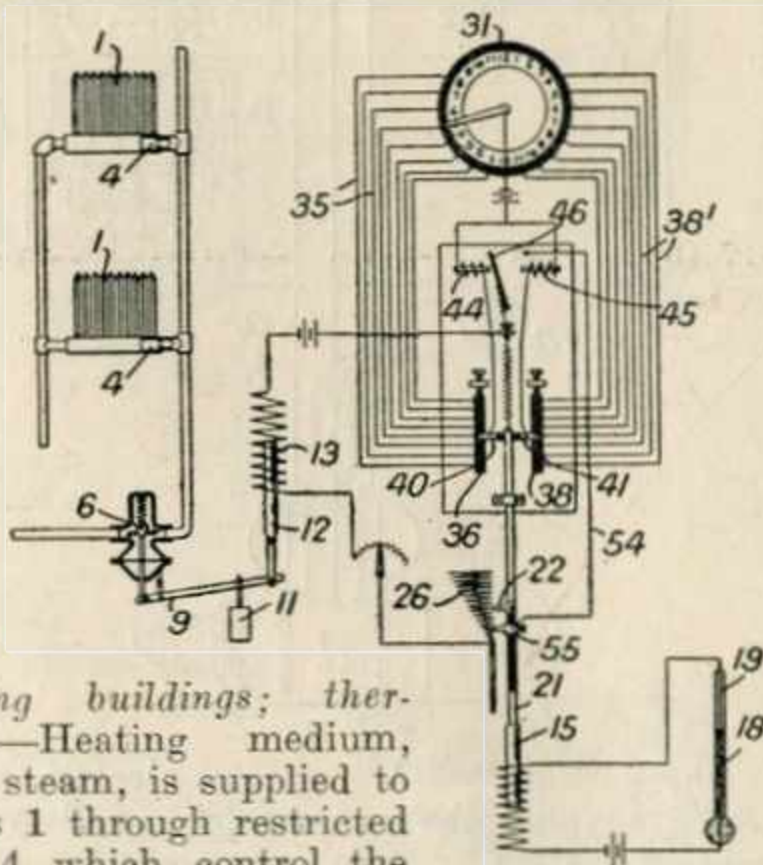

*Heating buildings; thermostats.*—Heating medium, such as steam, is supplied to radiators 1 through restricted orifices 4 which control the distribution to the system, the supply to the whole system being controlled

by a valve 6, of which the maximum opening is adjusted manually by means of a counterweight 11, and the subsequent adjustment is effected automatically under control of a thermostat 18, outside the building, in such a way as to maintain a uniform temperature within. In the arrangement shown, the thermostat comprises a thermometric tube in which is a resistance wire 19, more or less of which is short-circuited according to the height of the mercury. The wire 19 is in the electric circuit of a solenoid, the core 15 of which is attached to a spring-suspended rod 21 carrying a contact finger 22 moving over a resistance 26 in the circuit of a solenoid 13, the core 12 of which is connected to the balance lever 9 of the valve 6. The outside temperature thus controls the vertical movement of the rod 21 and contact finger 22, and hence, through variation of the resistance 26 in the circuit of the solenoid 13, the valve 6. Means are also embodied for reducing or cutting off the supply of heating medium during certain periods, such as at night, comprising a clock 31, the hour hand of which moves over contact pins set, in the case shown, at the hour divisions between 1 and 8 a.m. and 4 and 11 p.m. These pins are connected by conductors 35 and 38' to corresponding contacts on vertical bars 36, 38, over which move contact fingers 40, 41 carried by the vertically-movable bar 21. The fingers 40, 41 are in the circuits of solenoids 44, 45 respectively, which operate a switch arm 46. The switch 46, when moved to the right, closes a shunt circuit 54, connected to a contact finger 55 which cuts out the portion of the resistance 26 between it and the finger 22, and so increases the current through the solenoid 13 and causes further closure of the valve 6. This closing movement occurs at some period between the hours of 4 and 11 p.m., during which the contacts of the clock 31 come into operation, the exact hour being under the control of the thermostat 18, which adjusts the vertical position of the contact finger 41 through which the closing circuit is completed. In a similar manner the switch 46 is moved to the left to open the shunt circuit 54 and restore normal heating when simultaneous contacts are made, between the hours of 1 and 8 a.m., at the clock and at the contact finger 40. At the position shown of the parts, reduced heating will be initiated at 7 p.m. and full heating restored at 5 a.m. A rise in outside temperature, causing a lowering of the contacts 40, 41, advances the hour of closure of the closing circuit and retards that of the circuits which restore normal heating, a fall in outside temperature having the reverse effects.

**307,530. Clark, R.** Dec. 3, 1927.

*Steam traps.*—A tank or reservoir a to be drained of condensed water down to a predetermined level, is connected at the top by a pipe d<sup>1</sup> to inlet a<sup>1</sup>, and at a point below the desired water level by a pipe d<sup>2</sup> to inlet b<sup>1</sup> of a chamber c mounted on the side of the tank. A partition d is situated at the desired water level, so that if steam has access to its lower side, the pressure

in a closed system *e* communicating with its upper side, and containing water, is increased, while if the lower side is in contact with water, the pressure in the closed system is less. The system comprises a coil of piping *e*, one end communicating with the space above the partition *d*, and the other end with a diaphragm valve *h*

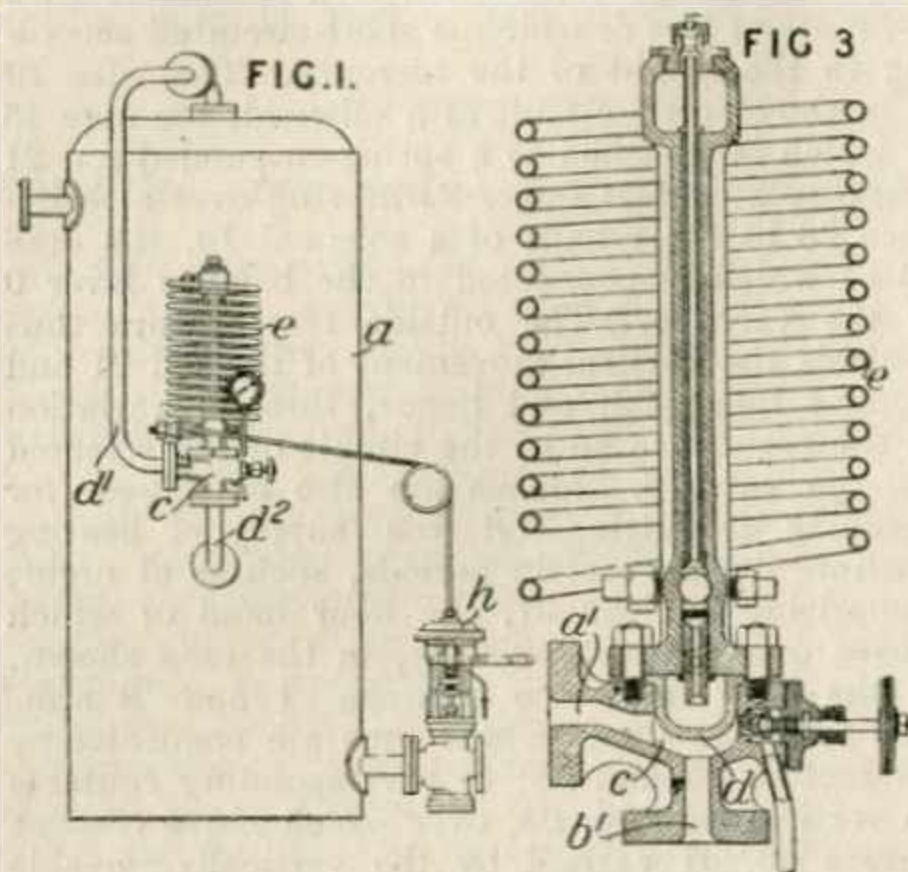

controlling the outflow from the tank *a*. The circulation in the coil *e*, and consequently the pressure generated in the coil, is controlled by a needle valve in a bye-pass across its ends. Removable plugs are provided to enable the closed system to be freed from air.

**307,592. Poole, A. R.** Feb. 7, 1928.

**Radiators.** — A metal radiating plate *A* for heating or cooling buildings is attached to a support *B* by screws *B*<sup>1</sup>, *B*<sup>2</sup>, and the support *B* is attached to the wall by a screw *C*. Heating or cooling pipes *D*<sup>1</sup>, *D*<sup>2</sup> are placed between the plate *A* and the wall, and the plate is adjusted to or from the pipes by means of the screws *B*<sup>1</sup>, *B*<sup>2</sup>. An insulating sheet *G* is placed next to the wall. The plate *A* may be flat or curved, and is preferably fixed in the space between picture rail and cornice.

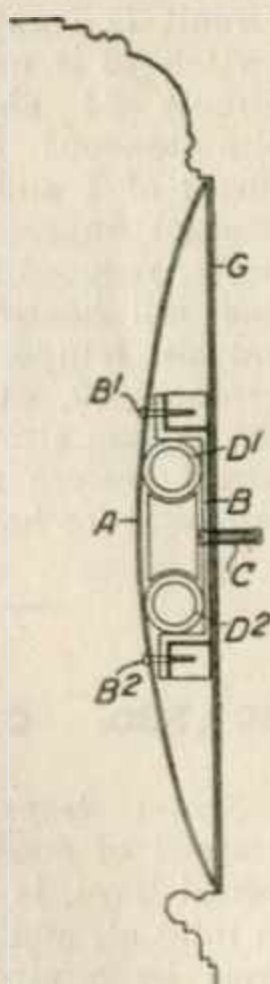

**307,678. Matthews, E. C.** July 5, 1928.

**Thermostats.** — A heat sensitive element for operating fire-alarms comprises a metal base *A* having an opening *B* over which a concave diaphragm *F* is secured. Above the diaphragm, a bridge *K* insulated from the base and carrying a contact *N*<sup>2</sup> is fixed at one end *K*<sup>1</sup> and adjustably held at the other end *K*<sup>2</sup> by a screw and slot. The diaphragm is protected by an apertured cover *G*. A spring contact *P* normally engages the contact *N*<sup>2</sup>, but is moved out of engagement, on a sudden rise in temperature, by a push pin *Q* secured to the diaphragm *F* and sliding in a bushing *Q*<sup>1</sup>. Ordinary climatic changes cause all parts to expand equally. In a modification, further contacts are provided on the bushing *Q*<sup>1</sup> and diaphragm *F*, so that expansion of the diaphragm serves to open one circuit and close a second.

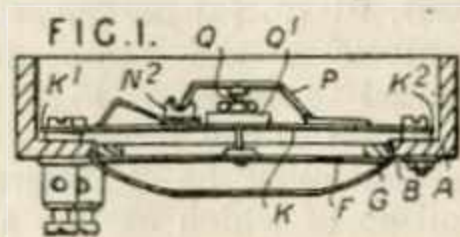

**307,718. Stone & Co., Ltd., J., and Darker, A. H.** Dec. 6, 1927.

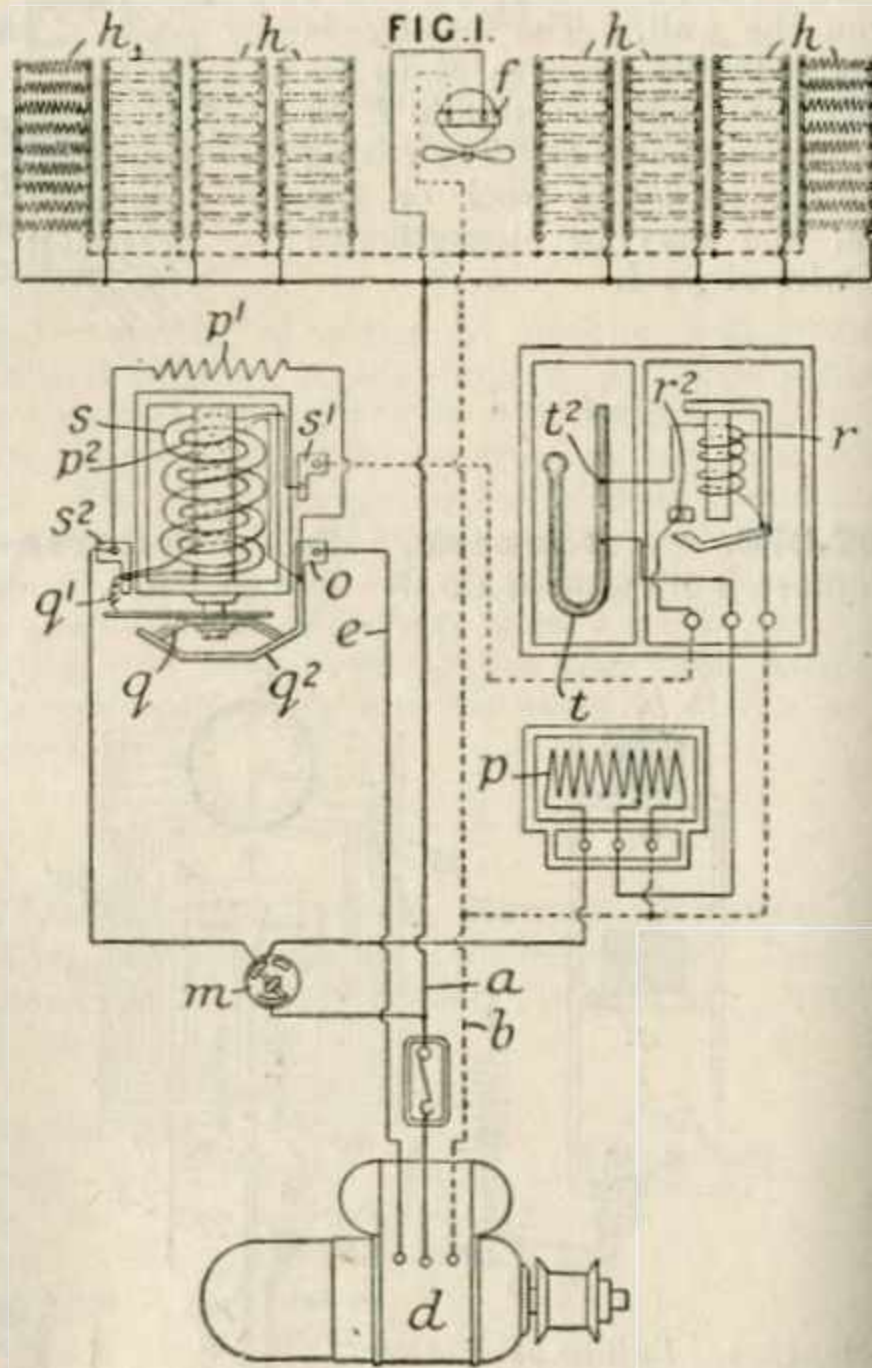

**Thermostats.** — A dynamo-electric machine which supplies the current for a railway vehicle heating system or which operates the compressor of a refrigerator is controlled by means of a heat-sensitive element which completes a low-voltage

circuit of a relay which controls the circuit of an electromagnetic switch which controls the dynamo-electric machine. An axle-driven dynamo *d*, Fig. 1, is connected by positive and negative leads *a*, *b* to heaters *h* and to a fan *f* for circulating the air. A mercury column thermostat *t* is connected to the coil *r* of an electromagnetic switch having a potential difference of about 1 volt derived from a potentiometer *p*. across the mains. The switch contact *r*<sup>2</sup> is connected to the terminal *s*<sup>1</sup> of the solenoid coil *s*, the other end of which, *s*<sup>2</sup>, is connected through a hand switch *m* to the positive main *a*. The field winding of the dynamo is connected by a wire *e* to a terminal *o* and thence through resistance *p*<sup>1</sup> and terminal *s*<sup>2</sup> to the main *a*. The resistance *p*<sup>1</sup> is shunted by a coil *p*<sup>2</sup> wound non-inductively with the coil *s*, and its effective resistance is varied by making the resistance *p*<sup>1</sup> an interchangeable unit. The contact member *q* carried by the armature is connected by wire *q*<sup>1</sup> to terminal *s*<sup>2</sup>, and normally rests on contact *q*<sup>2</sup>, so that the resistances *p*<sup>1</sup>, *p*<sup>2</sup> in series with the dynamo field winding are short circuited, and the maximum current supply is available for the field windings. If the thermostat makes contact at *t*<sup>2</sup>, the relay operates to raise the contact member *q* insert the resistance *p*<sup>1</sup>, *p*<sup>2</sup> in the field windings, and thereby reduce the dynamo excitation and supply of current to the heaters *h*. The position of the contact *t*<sup>2</sup> is adjustable to vary the temperature control point. In the application to a refriger-

ator control, Fig. 3 (not shown), the compressor is driven by a series-wound motor supplied by an axle driven dynamo, and the field winding of the motor is paralleled by a variable resistance in series with the non-inductive resistance on the solenoid. The non-inductive resistance is normally short-circuited, but the short-circuit is broken by the relay at the predetermined temperature, thus increasing the resistance in parallel with the motor field winding and increasing the current in the field winding. In another modification, applicable to a shunt-wound motor, Fig. 4 (not shown) the shunt winding of the motor is in series with a variable resistance which is normally short-circuited, but is placed in the circuit by the relay switch at a predetermined temperature. A vehicle may have a change-over switch for connecting the mains *a*, *b*, to a supply station when the vehicle is at rest. The thermostatic control operates on the motors when these are employed in a cooling plant, or on the dynamo of the supply station in the case of heating. Alternatively, the heating may be varied by the insertion of resistances in the circuit of the heaters. On refrigerator vans, the compressors may be driven mechanically from the running axles, and the electric motor drive may be employed only with current from a supply station when the van is at rest. The thermostatic device may have more than two contacts, and an embodiment of this device is described in Fig. 5 (not shown).

**307,741. Dunham Co., Ltd., C. A.,** (Assignees of Dunham, C. A.). March 12, 1928, [Convention date]. Void [Published under Sect. 91 of the Acts].

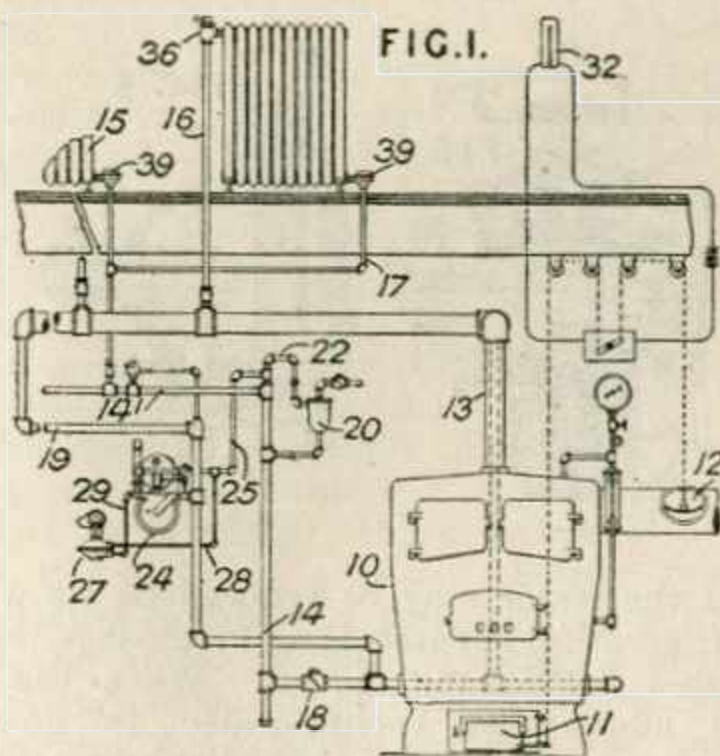

*Heating buildings.*  
—In a steam-heating system for buildings, the steam in the radiators is maintained at sub-atmospheric pressures by an exhauster, the

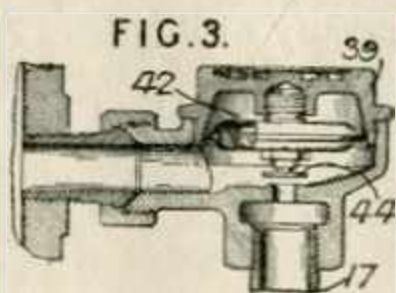

quantity of steam supplied is controlled by a thermostat or otherwise, and a valve for discharging condensate is operated by a capsule containing a liquid adapted to exert pressures in excess of the vapour pressure of steam at the same temperature by a substantially constant amount. A boiler 10 supplies steam through pipes 13, 16 to a radiator 15 which discharges through valve 39 and pipes 17, 14 to the boiler. A drip pipe 19 is connected from the steam pipe 13 to a point between check valve 18 and the boiler. The pipe 14 is provided with an air eliminator 20. A vacuum pump 24 is connected by suction pipe 25 to the piping 22 above the level of the horizontal return pipe 14. The pump is controlled by a device 27 connected by pipes 28, 29 to the low and high pressure sides of the system, so as to maintain a sufficient pressure difference to ensure the removal of water of condensation and air. The quantity of steam supplied may be controlled by a reducing valve on the pipe 13, or by means of a thermostat 32 controlling the furnace dampers 11, 12. The radiator inlet valve 36 is associated with an apertured plate to restrict the inflow of steam when the heating is started, but the aperture is sufficiently large to have no influence in normal operation. The steam trap 39 comprises a flexible capsule 42 carrying a valve 44 controlling the outlet pipe 17. The capsule contains a volatile liquid having a vapour pressure exceeding by a constant amount over a range of temperature,

the vapour pressure of steam. The liquid may comprise benzene 99.5 per cent, and denatured alcohol 0.5 per cent. The alcohol contains ethyl alcohol 10 parts, methyl alcohol 1 part, the total volume of alcohol being 95 per cent, and the remainder being water. The system is adapted to operate under low average pressures, down to a vacuum of 25 inches of mercury.

**308,265. Saupe, R., and Mielke, E.,** (trading as Saupe & Mielke), and **Christians, C.** March 20, 1928, [Convention date].

*Heating by circulation of fluids.* — In a hot-water heating-system embodying a storage tank, the supply and discharge of water to and from the tank is effected by means of the pressure due to the circulating pump. The boiler 1 supplies water through pipe 2 to the heat utilizing devices 4, and the water returns through pipe 6, and pumps 8 to the boiler. The storage tank 13 is connected between the pipe 2 and both sides of the pumps 8. The branches 15, 16 are provided with valves I, II, controlled by a thermostat 21, which also controls a valve 26 in the return pipe.

When the temperature in the pipe 2 is normal, the thermostat 21 keeps the valves I, II, closed, but if the temperature rises, valve II is opened and cold water from the lower part of the tank 13 is drawn into the system by pumps 8 and is replaced by hot water from the pipe 2. If the temperature in the pipe 2 is too low, valve I is

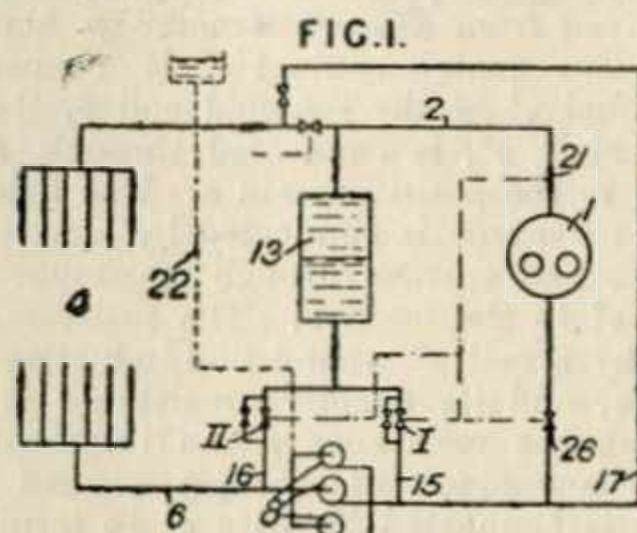

opened, cold water is delivered by the pumps into the tank 13, and hot water is displaced into the system. At the same time, valve 26 is closed further. A by-pass pipe 17 is provided, so that colder water may be mixed with the hot water in the pipe 2, and the temperature of water utilized may then be lower than that of the water produced and stored.

**308,773. Electrolux, Ltd.,** (Assignees of *Platen-Munters Refrigerating System Aktiebolag*). March 30, 1928, [Convention date].

*Thermostats.* — A thermostatic element 3, Fig. 1, containing a congealable medium such as water is arranged so that a part is in metallic contact with the cold producing or transferring member 6 of a refrigerating cabinet while the remainder is exposed to the air of the cabinet. The force due to change of volume is transmitted through a liquid in a tube 4, preferably made flexible by a loop 5, to a bellows or like chamber 18, Fig. 4, to actuate a cooling-water supply valve, and the flow of cooling-water controls a switch in the driving or heating circuit of the refrigerating apparatus. The element 3 may be set vertically as shown in Fig. 1, or horizontally, as shown in Fig. 3, with its end 8 secured by clamps 7. When set horizontally a perforated tortuous band 9 or other

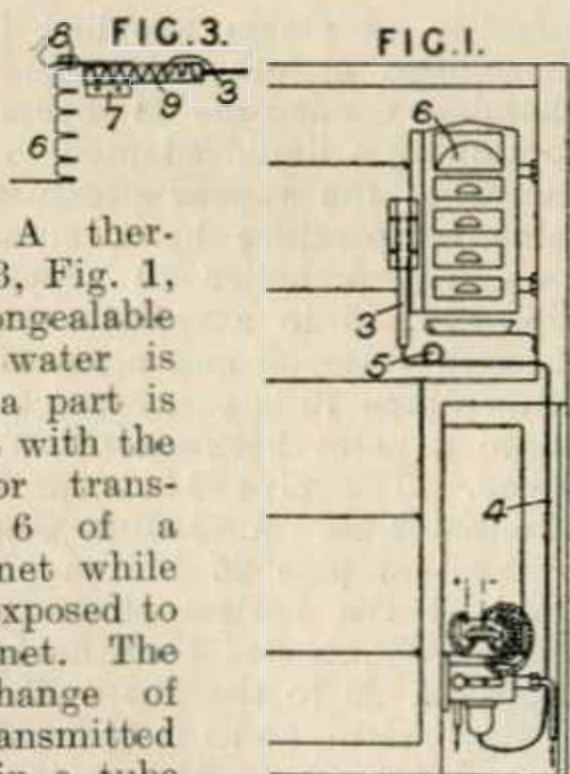

baffle device is inserted in it to prevent movement of the unfrozen liquid. The control is varied by changing the extent of contact of the element with the evaporator. The bellows member 18 contains a spring pressed piston 19 fitted with an inner spring pressed valve member 22 adapted to seat against a nozzle 12 extending from a passage 14 through which cooling-water flows to the refrigerating apparatus. The pres-

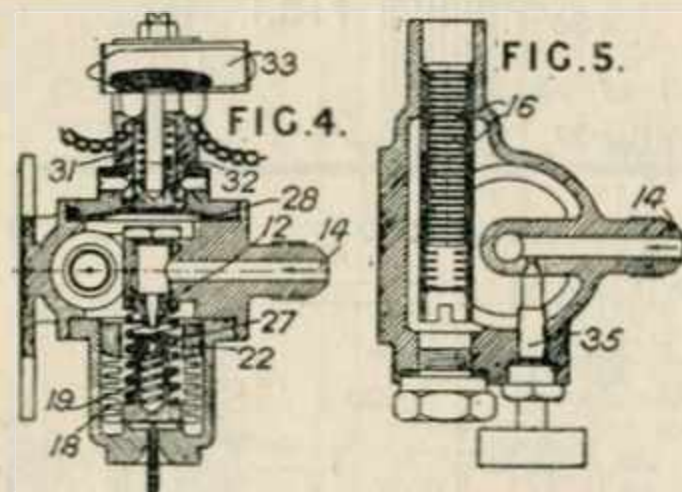

sure of the water may be reduced on its way to the refrigerating apparatus, as by passage through perforated baffles 16, Fig. 5. When the thermostat allows the cooling-water to flow the water pressure acts through a diaphragm 28 and rod 32 against the action of a spring 31 to close a mercury switch 33. A hand operated by-pass valve 35, Fig. 5, is provided in the cooling-water passage, to cut out the thermostatic control.



**308,976. Mautner, I.** (Assignee of Deutsch, S.). April 2, 1928, [Convention date].

**Radiators.**—A radiator element for heating buildings comprises a vertical tubular member 1 of triangular cross section, the side 2 of which is provided with vertical ribs 3. Horizontal connecting members are provided at the upper and lower ends of the members 1, and are threaded to receive the connecting nipples, so that a radiator of any desired size may be built up. The side 2 of the tubular member may be extended laterally at 4 beyond the rear walls 5.

According to the Specification as open to inspection under Sect. 91 (3) (a) radiators which are not placed near a wall may have radiating fins on both sides. This subject-matter does not appear in the Specification as accepted.

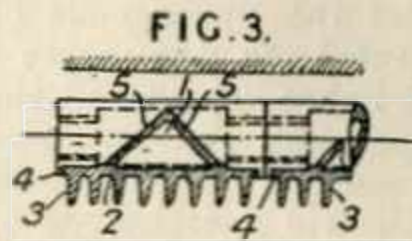

alarm circuit. Sagging of the wire opens the circuit. This subject-matter does not appear in the Specification as accepted.

**309,222. Hammond, C. F., and Shackleton, W.** Jan. 6, 1928.

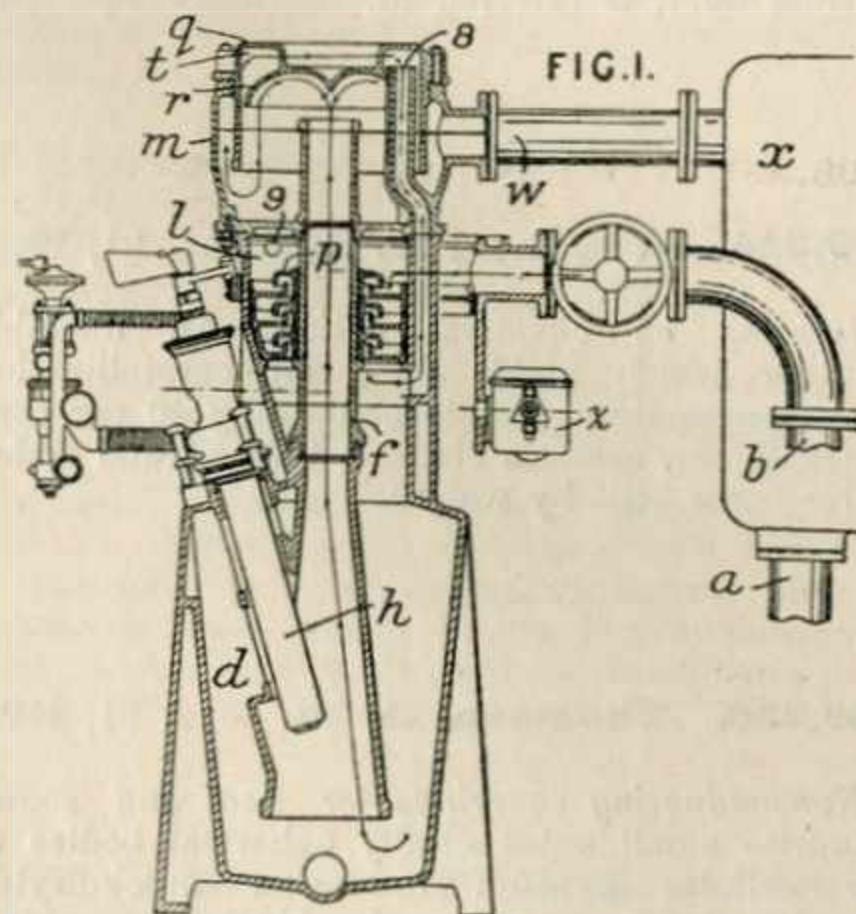

**Heating buildings.**—A heating system for buildings comprises an air-lift apparatus receiving combustion gases from a submersible burner, connected to the head of the cold liquid return column of the circulating system so as to heat and raise liquid to a tank at the head of the hot descending column. The combined heating and air-lift apparatus illustrated may be situated at the top of a building and connected with the radiators by a descending hot water pipe *a* and rising cold water pipe *b*. The submersible burner *h* projects into the foot of the air lift tube *f*, which projects downwards into a chamber *d*. The tube *f* passes through a heat interchange chamber *l* to a separator *m* having an annular deflector *r*. An annular space *t* is formed in the cover *q*, which also projects downwards into the chamber *m* to form a water seal. A delivery pipe *w* opens into a tank *x* at the top of the descending hot water pipe *a*, and the rising cold water pipe *b* opens into the top of the chamber *l*. The water level in the chamber *l* is controlled by a float valve in a chamber *z*. The fuel and air supplied to the burner may be controlled by a thermostat subject to the temperature of water in the pipe *b*, or the chamber *m*, or the tank *x*. In operation, the aerated water in the column *f* overflows into the chamber *m*, where gases are separated and pass into the space *t*. The hot water overflows into the tank *x* and passes down through pipe *a*, displacing cold water up the pipe *b* and into the chamber *l*, where it passes over the baffles *p* and meets the hot gases which have passed downwards from space *t* through passage *8* to the underside of the series of baffles. The

**309,120. Bory, G. H. L. G.** April 5, 1928, [Convention date].

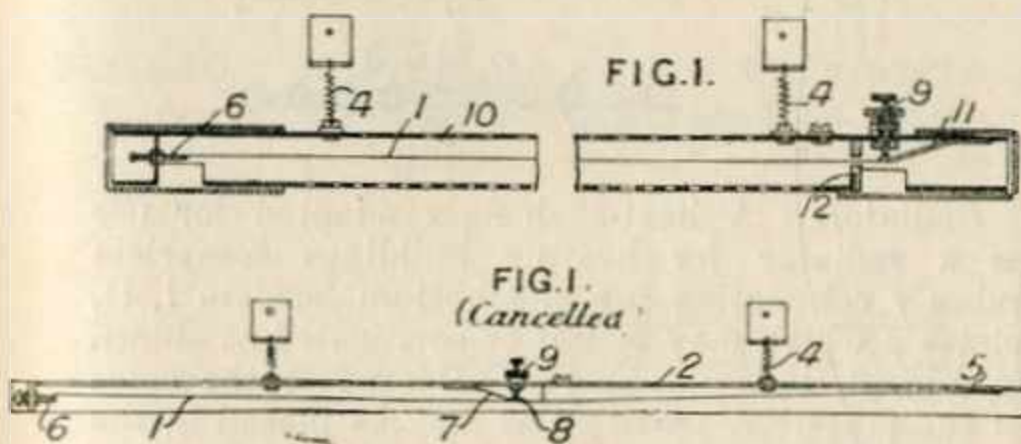

**Thermostats.**—In an alarm device of the sagging wire type, the wire 1 is enclosed in a perforated tube 10, and is made fast at one end to an adjusting screw 6, and at the other end to the free end of a leaf spring 11 secured to the tube. The tube is suspended by springs 4 to damp vibration. When the wire 1 is cold, it holds the end of the spring in contact with a screw 9 in an alarm circuit. When the wire is heated and expands, it allows the spring to move in a direction perpendicular to the wire, breaking the contact. A washer 12 forms a dust-proof enclosure for the contacts. In a modification adapted for signalling the extinction of a lighted lamp, the tube has a heat-insulating lining and an aperture closed by a pane of mica is arranged above the lamp. While the latter is alight, the wire is expanded, and the alarm circuit is closed; if the lamp be extinguished, the wire contracts and breaks contact.

The Specification as open to inspection under Sect. 91 (3) (a) comprises also a construction, Fig. 1, (Cancelled) wherein the wire 1 is enclosed in a casing 2 formed of perforated angle irons, is made fast at both ends, and passes over the hooked end 8 of a contact spring 7 normally held by the wire in contact with a contact 9 in an



**ULTIMHEAT<sup>®</sup>**  
**VIRTUAL MUSEUM**

cooled gases finally escape through opening 9. In another modification, the separating chamber *m*, heat interchanger *l*, and air lift tube are all separated, and connected by pipes. In another modification the water directly heated by the submerged combustion burner does not pass into the heating system, but is isolated in a separate chamber. The combustion products are thus purified, and are then supplied to a separate air-lift pipe. Specification 265,254 [Class 102 (ii), Water &c., Raising &c.], is referred to.

**309,244. Crooker, H. L.** Jan. 21, 1928.

*Heating by chemical action.*—An unstable solution which yields heat on crystallization comprises sodium acetate containing 40 per cent water 16 oz., calcium chloride 0.2 oz., and added water 6 per cent by weight.

**309,256. Thomson, G. M.** Jan. 31, 1928.

*Nonconducting coverings for heat and sound* comprise small substantially spherical bodies of dry cellular gypsum or other quick-drying cementitious material, preferably waterproofed. A slurry of gypsum or the like containing uniformly-distributed gas bubbles (obtained e.g. by mixing calcined gypsum with an ingredient which releases gas on the addition of water) is run on to a continuous belt with hemispherical or cylindrical cavities, and a second belt similarly formed is pressed against it under a squeeze roll to shape the bodies. After setting and drying, the balls are waterproofed by dipping into casein glue. The balls are formed of various sizes to fill voids in walls. Crushed cellular gypsum may be added to complete the filling.

**309,436. White, A. E.,** (*Bastian-Morley Co.*). Oct. 10, 1927. *Divided on* 309,415, [Class 39 (iii), Heating by electricity].

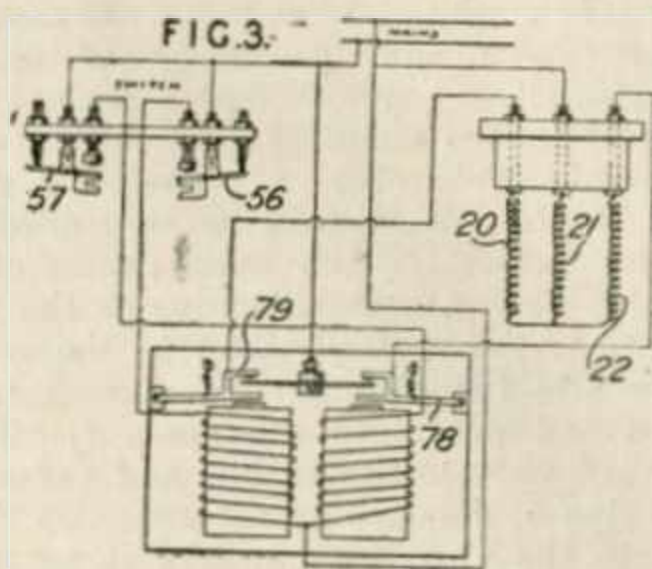

*Thermostats.*—The circuits of a number of electric heating elements are controlled ther-

mostatically by progressively actuated switches. The heating unit comprises coils 20, 21, 22 connected together at their lower ends. The upper end of coil 21 is connected to one supply lead and the upper ends of the other coils are connected to the other supply lead through relay switches 79, 78 and thermostatic switches 56, 57 operating in sequence and constructed as described on Specification 309,415, [Class 38 (v), Electric switches &c.]. The upper ends of the coils 20, 22 may be connected directly to the switches 56, 57 if desired. More than one thermostat may be employed.

**309,445. Kranzlein, G., and Samesreuther & Co. Ges.** April 10, 1928, [Convention date].

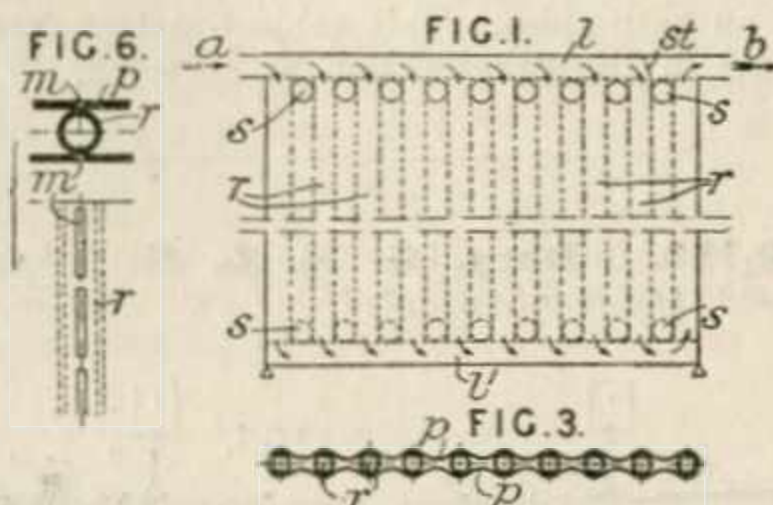

*Radiators.*—A heat-exchanger adapted for use as a radiator for heating buildings comprises tubes *r* connecting top and bottom headers *l, l'*, plates *p* which may be flat or corrugated as shown in Fig. 3, being welded or soldered to the sides of the pipes. A partition *st* may be placed in the header *l* to cause the outflow *b* to be at the same end as the inflow *a*. Holes *s* at top or bottom of the side sheets *p*, or at both, allow of entry of air, for example, to the spaces between the pipes. The device may be built in a wall, for example separating two rooms. Fig. 6 shows a method of securing, the plates being slotted as at *m* opposite the pipes and solder applied to the slots. The pipes may be split and splayed at their ends and then welded to openings in the header pipes. The openings may be progressively larger the further from the entry point *a*.

**309,753. Talbot-Stead Tube Co., Ltd.** and **Mellor, A. H.** May 4, 1928.

*Heating by circulation of fluids.*—The furnace end *a* of a Perkins' tube is formed internally and externally of smaller diameter than the remainder, and this reduced part is surrounded by a reinforcing sleeve *b*, which may be made of chromium or chromium-nickel steel.

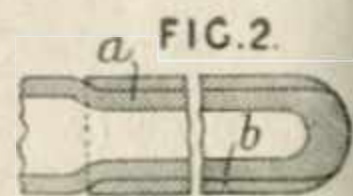

**310,166. Kricheldorff, G., and Ruhkopf, A.** March 31, 1928.

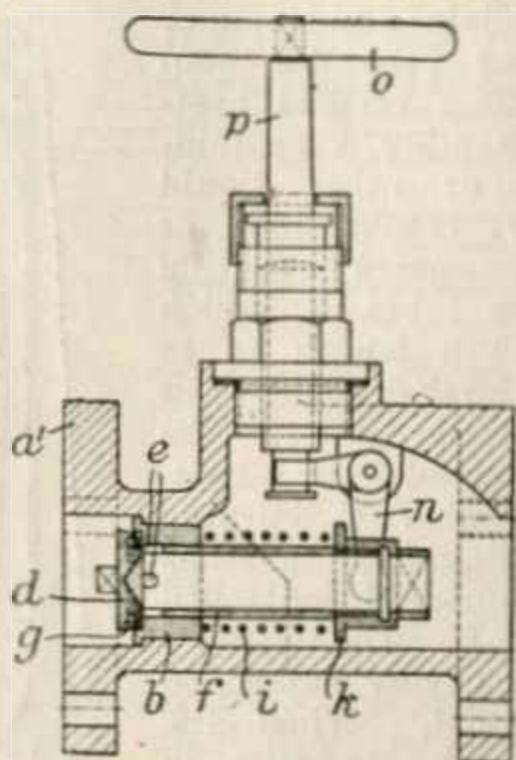

*Steam traps.*—A device for draining condensed water from a steam pipe or the like comprises a tube *f* having a frusto-conical head *d* with an annular rim *g* seating in a groove in the sleeve *b*. Lateral openings *e* are provided just below the head *d*. A spring *i* acting against a flange *k*

presses the valve on its seating, and the valve may be lifted by means of a hand wheel *o*, screwed spindle *p*, and lever *n*. The flange *a* is bolted to the pipe to be drained, and if the latter is full of water and therefore cold, the valve is lifted by means of the hand wheel until the escape of steam indicates that the water has been discharged. The spindle *p* is then screwed down again to allow the valve to close, and any subsequent condensate is automatically discharged by lifting of the valve, which is stated to be due to the vacuum caused by condensation of steam.

**310,572. Schmidt, E., and Dyckerhoff, E.** Feb. 2, 1928. *Addition to 266,177.*

*Nonconducting coverings for heat.*—The heat insulation described in the parent Specification, according to which layers of air or air spaces are bounded by sheets of bright metal foil, is modified by replacing the metal foil with a suitable material such as paper, cardboard, cork, asbestos, or peat, having a thin bright metallic coating, which may be applied by electrolysis or by spraying, or as a metallic lacquer.

**310,950. Rheinhold & Co. Vereinigte Kieselguhr-und Korkstein-Ges.** May 4, 1928, [Convention date]. *Addition to 305,048.*

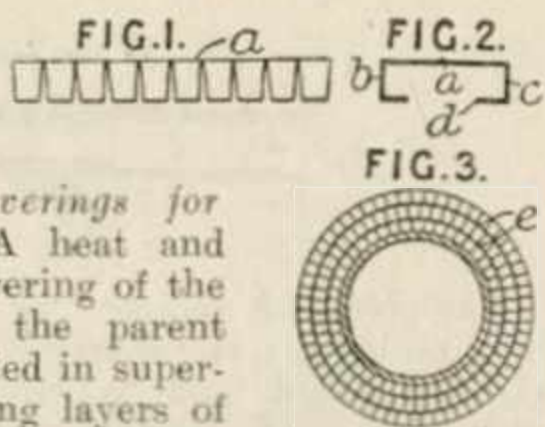

*Nonconducting coverings for heat and sound.*—A heat and sound insulating covering of the kind described in the parent Specification is applied in superposed layers enclosing layers of air. The sheet metal members *a* may be made in continuous lengths, with turned-over sides *b*, *c*, and inner extensions *d*. The parts *b*, *c*, *d* have notches cut out so that the strip may be bent around a curved object. Metal foil *e* or compressed powder or fibre insulation may be interposed between the layers. The device is suitable for vertical pipes since continuous vertical air columns are not formed.

**310,985. Harrison, C. F. R., and Imperial Chemical Industries, Ltd.** Dec. 31, 1927.

*Steam-traps.* — A device for separating liquids and gases under pressure, particularly the products of destructive hydrogenation, comprises a vessel 1 having therein a chamber 3 surrounded by the gas and supported by a spring 11. A tubular extension 13 having a lateral opening 12 is a sliding fit in tubular part 2 of the vessel 1. The mixture of gas and liquid is introduced by a pipe 5 into the chamber 3 and is discharged through the opening 12 into an outlet 9 when the vessel is sufficiently depressed by the weight of the liquid therein. The gas is led off through a pipe 7. In modifications, the vessel 3 may be of uniform diameter and may be spring supported from above instead of from below.

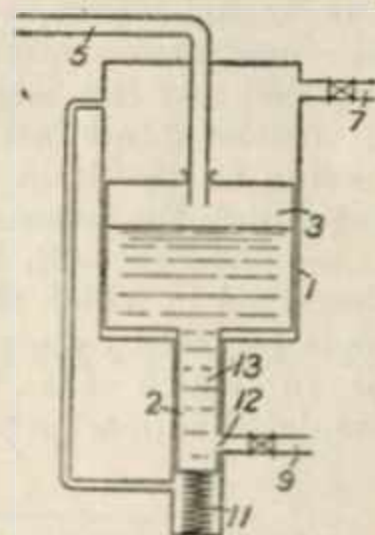

**311,155. Eitel, F.** Aug. 16, 1928.

*Thermostats.* — Apparatus for indicating temperature comprises a curved expansion thermometer *T* pivoted about an axis *A* so that expansion or

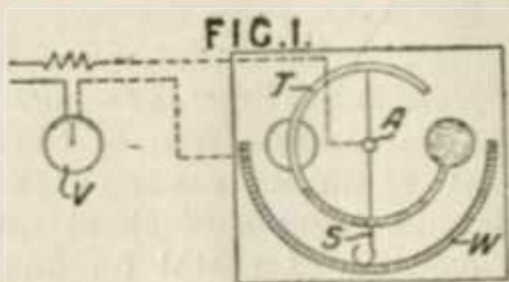

contraction of the mercury causes angular movement of the thermometer. A contact spring *S* carried by the thermometer moves over a resistance *W* arranged in a circuit including an indicator *V* or a relay controlling a heating resistance &c.





**ULTIMHEAT** 311,662. **Telefunken Ges. für Draht-  
VIRTUAL MUSEUM** *se Telegraphie.* May 11, 1928, [*Con-  
vention date*].

*Thermostats.*—A process of manufacture of cells sensitive to infra-red radiation consists in the cathodic atomization (sputtering) on a suitable base of an alloy of selenium and heavier metals, such as tellurium, from the same group in the periodic system, or, such as bismuth, from the neighbouring groups. The inertia of the cell may be reduced by the addition of up to 2 per cent of silver; and the sensitive material may be heat treated to increase its infra-red sensitivity and is preferably not thicker than the depth of penetration of the radiation.

**311,682. Morse, S.** Feb. 14, 1928.

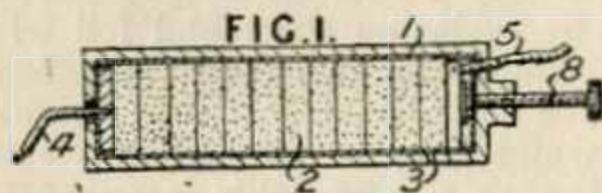

*Thermostats.*—In order that an electric heating-element of the type comprising a number of carbon blocks or the like may maintain its temperature approximately constant the blocks are mounted in or on a container or support having a co-efficient of expansion greater than that of the conducting blocks, so that when the temperature becomes excessive the pressure on the blocks is reduced and the resistance increased. A number of blocks 2 are arranged in a metal casing 1, having an insulating lining 3 and a screw 8 for regulating the pressure on the blocks, and current is supplied through leads 4, 5. Modifications are described in which the container is of spiral form, or is replaced by a spiral wall on the base plate; or in which the blocks are threaded on an insulated support which may be straight or spiral.

**311,710. British Thomson-Houston  
Co., Ltd.,** (Assignees of *Randolph, C. P.*).  
May 14, 1928, [*Convention date*]. *Void*  
[*Published under Sect. 91 of the Acts*].  
*Drawings to Specification.*

*Thermostats.*—A bimetallic strip for use in thermal switches is made of two strips of invar and monel metal, and is slit down the centre. The switch is applied to controlling the heating circuit of an electric iron. Specification 144,767 [*Class 37, Electricity, Measuring &c.*], is referred to.

**311,787. Shishkoff, P.** Nov. 17, 1927.

*Heat-storing apparatus.*—A heat accumulator and steam or other vapour generator consists of a long vertical heat-insulated chamber A containing water or other liquid heated by combustion or other hot gases passing through flue tubes F, which are of such a length as to create a natural draught of at least  $\frac{1}{4}$  in. water gauge. The flue tubes extend from a combustion chamber C burning powdered, liquid, or gaseous fuel to an outlet G controlled by a damper H. The chamber is partly or wholly embedded in the ground. When the temperature and pressure in the chamber have been raised to the desired limit, its lower end is closed by a door D, and if water is used in the accumulator, the stored energy is drawn off, as steam through a pipe K. The accumulator may be used in connection with the apparatus described in Specifications 260,094 and 266,621, [both in *Class 123 (ii), Steam generators*].

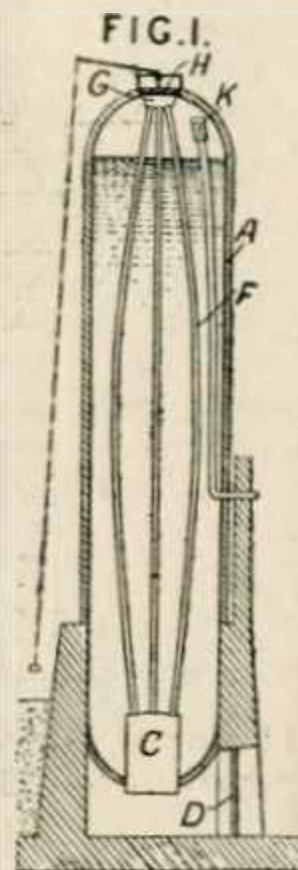

**311,840. Rennie, W.** Oct. 16, 1928.

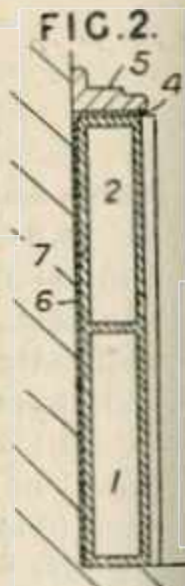
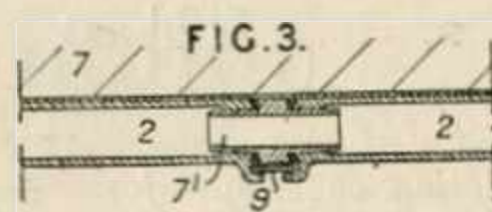

*Radiators.*—A radiator for heating buildings is shaped as a skirting board and is provided with flow and return compartments 1, 2. An asbestos sheet 6 is inserted between the radiator and wall 7 and is turned over at 4 between the radiator and bead 5. The sections are connected by couplings 7' which are concealed by plates 9 slid into grooves formed in the adjacent sections.

**312,631. Rheinhold & Co. Vereinigte  
Kieselguhr-und Korkstein-Ges.** May  
29, 1928, [*Convention date*]. *Addition to*  
305,048.

*Nonconducting coverings for heat and sound.*—In a modification of the parent invention, the heat-insulating covering consists of a plain continuous band *a* of sheet metal, pasteboard, with a coating of metal on one or both sides, wood veneer, or the like, with lateral divided spacing



walls *b*, Fig. 1. For insulating a pipe *c*, Fig. 3, the walls *b* may be on one edge only of the band



*a*, the other edge being supported by overlapping the band beneath it, as shown. An outer shell *d* may be fitted.

**312,868. Benham & Sons, Ltd., and Allensby, C. R.** Aug. 15, 1928.

*Radiators.*—The pipes in a heating system for buildings of the kind described in Specification 264,004 are secured to the cover pieces by means of spring clips *e*<sup>1</sup>, *e*<sup>2</sup> which pass round the cover piece *d* and grip the pipe *b*. The pipes are arranged in a ceiling *a*.

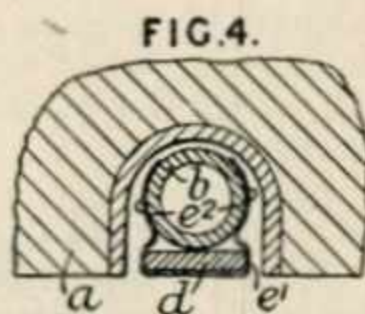

**312,953. Besson, J. V. H.** Feb. 2, 1928.

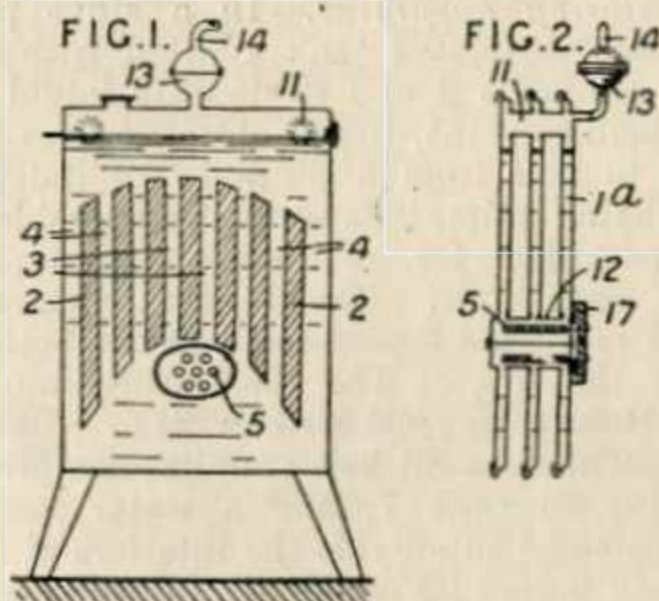

*Radiators.*—A radiator comprises relatively thin elements *1*<sup>a</sup> connecting upper and lower tubes *11*, *12* and containing a series of partition *2* arranged in echelon to form water-circulating passages *3*, *4*. The water may be heated by electric resistances *5* carried by a screw cap *17* and located in the lower tube *12*; or external gas burners may be used. A spherical expansion chamber or condenser *13* is provided the lower half of which serves as a filling funnel when the upper half is removed; a tube *14* may be provided for filling under pressure, or to carry an alarm whistle. In a modification a radial arrangement of elements is adopted, or the dividing partitions *2* may be in the form of vertical tubes.

**313,041. Schiele, E. L. R. A., and Wittenburg, F. H.,** (trading as Meyer, R. O., [Firm of]), and Margolis, A. June 5, 1928, [Convention date].

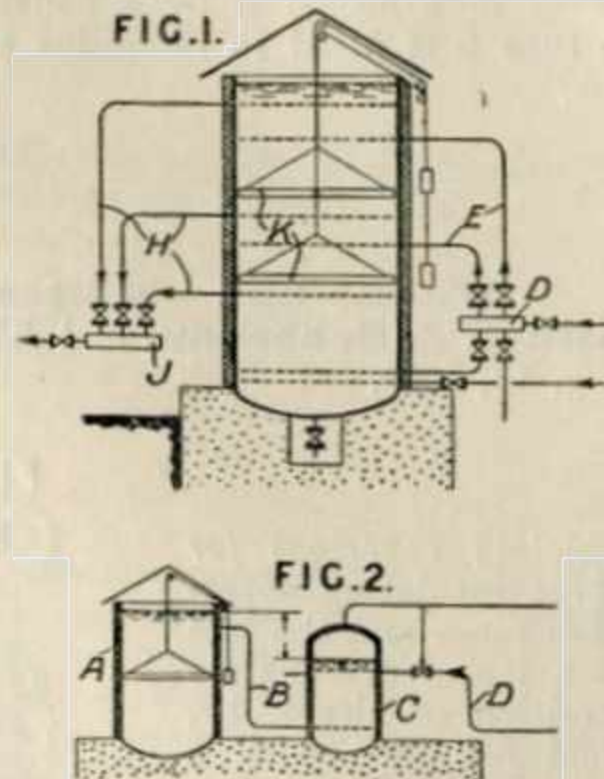

*Heating buildings.*—An open hot water reservoir resting at or below ground level and rising to a height corresponding to the highest static pressure, and which may also be used to receive expansion water, is used in a heating system. Heated water is distributed by a distributor *D* to pipes *E* leading to zones in the reservoir of different temperature, such zones being kept substantially distinct by plates *K*. Water may be drawn off as desired by various zone delivery pipes *H* leading to a collector *J*. In a modification, Fig. 2, a reservoir *A* has a single plate and is connected by a pipe *B* with a closed reservoir *C* the level of the water in which is lower than that in the reservoir *A* which maintains a pressure in reservoir *C* corresponding to that of steam liberated from superheated water fed through the pipe *D*.

**313,291. Dewrance, Sir J.** May 22, 1928.

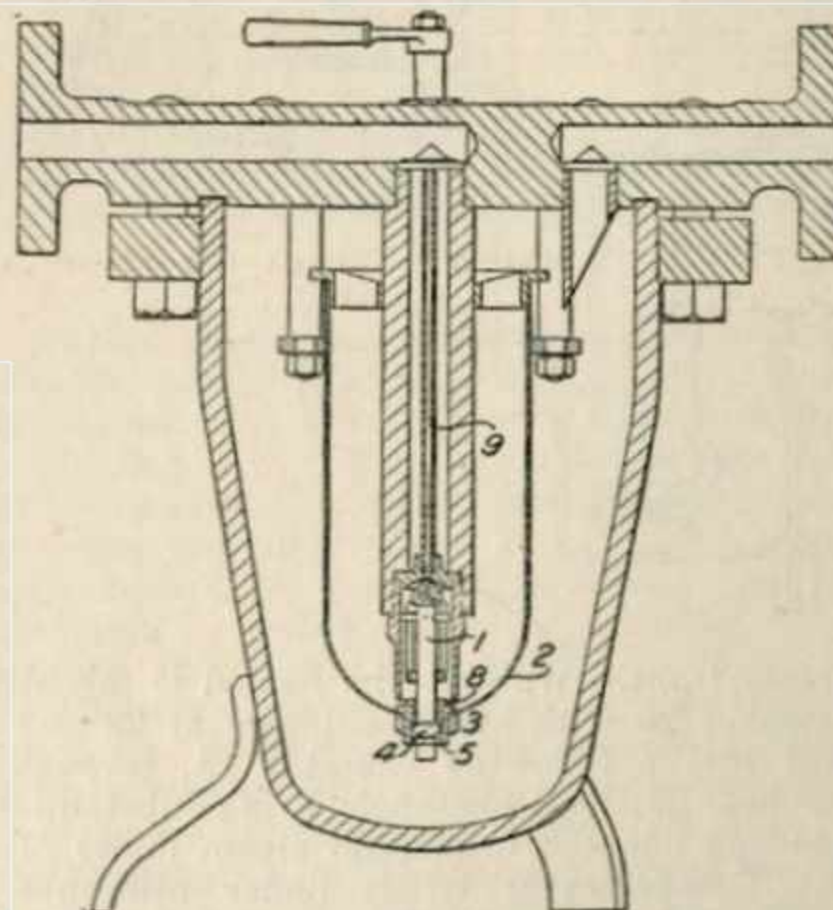

*Steam traps.*—In steam traps such as those described in Specifications 27258/11 and 261,909,

float operated main and pilot valves, the pilot valve 1 is directly attached to the float 2 by a ball and socket joint 3 devoid of lost motion. The end of the pilot valve stem forms the ball 4, which is held in a socket 5, by a collar 8. A small bore tube 9 is fitted to minimize the rate of discharge.

**313,364. Wärme-und Kälteschutz Ges. Althoff & Schoenau, and Althoff, P.** Aug. 13, 1928.

*Nonconducting coverings for heat.*—A heat insulating covering for steam pipes and the like consists of a jacket of concrete or a composition of kieselguhr, gypsum, and fish glue with a filling of slag-wool. The jacket *d* is supported by wire netting *b* mounted on a skeleton composed of rings *g* and bracket *a*, and the space between the wire netting and the pipe is filled with slag-wool or the like. Alternative forms of the brackets *a* and the method of securing them to the rings *g* are described.

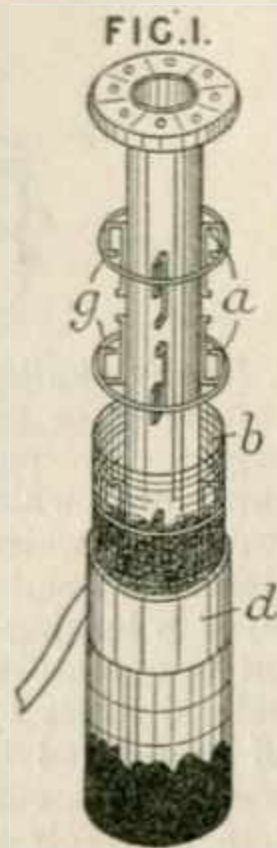

**313,481. Soc. l'Auxiliaire des Chemins de Fer et de l'Industrie.** June 12, 1928, [Convention date].

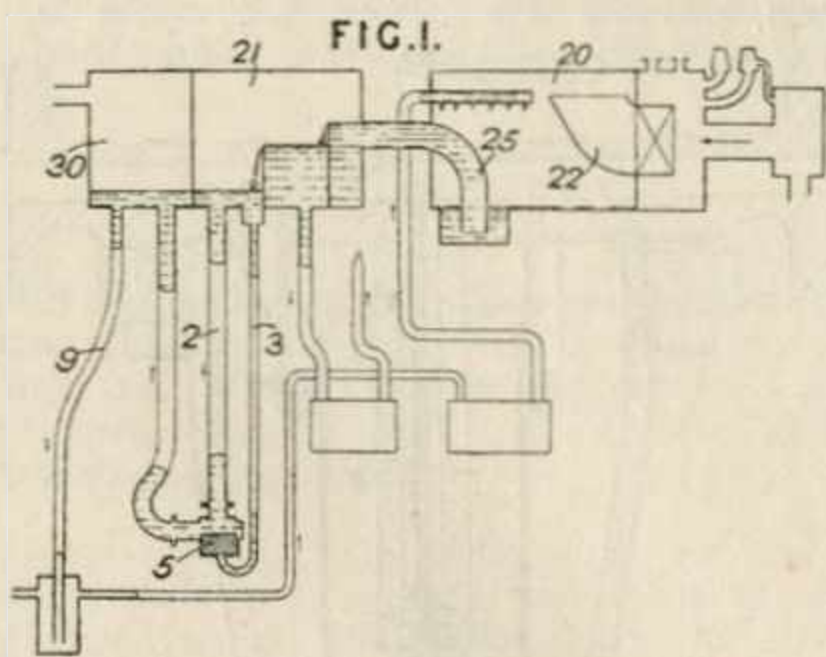

*Steam traps.*—Water to be heated is mixed in a chamber 20 with steam entering at 22 and is passed into a following chamber 21, through a water seal 25, both chambers being substantially closed and adapted to contain steam under pressure. Compartment 30 is under atmospheric pressure and is connected by a pipe 9 with the suction side of the feed pumps. Hot water is delivered from chamber 21 to compartment 30

through a discharge tube 2 with a valve or other device 5 so disposed in the tube that one face is subjected to a pressure which depends on the steam pressure, and the head of water in the tube, while the other is subjected to a substantially constant pressure added to the steam pressure. As shown, the constant pressure is that of the column of water in the tube 3, but it may be provided by a spring. By this means water is discharged without loss of steam. Specification 290,598, [Class 64 (i), Heating liquids &c.], is referred to.

**313,638. Kirkwood, J. C. P.** Feb. 16, 1928.

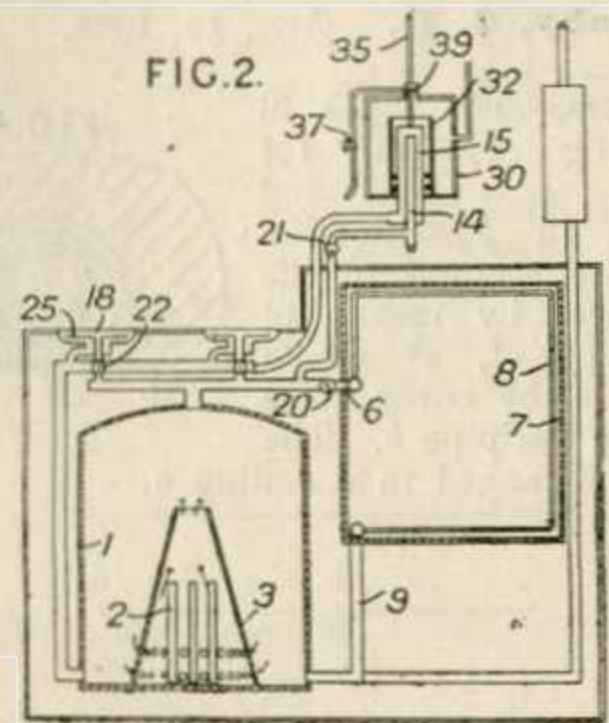

*Heat-storing apparatus.*—In a stove provided with a heat-insulated tank 1 fitted with electric heating elements 2 and containing liquid having a high boiling point, the liquid circulates by connection to and from a plurality of independent heat-utilizing units, independently operable means being provided for regulating the circulation through each unit. The heating elements are enclosed in a hood 3 perforated at the bottom and open at the top. The circulating liquid is a mineral lubricating oil with a flash point above 500°F. The heat-utilizing units comprise hot-plates 18, an oven 7, and a water heater 30. Baffle plates 25 sub-divide the interiors of the hot-plates and valves 22 are fitted on the inlet sides. A number of tubes 8 arranged in the oven are coupled to the tank by pipes 6, 9, a valve 20 being arranged on the inlet pipe 6. In the water heater the oil flows through concentric tubes 14, 15 under the control of a valve 21. A pipe 39 for the purpose of preventing an air-trap is fitted to the tube 15, and is lead-sealed after the oil system is filled. The tube 15 is surrounded by a shell 32 open at the top and perforated at the bottom. The water heater is coupled to a hot-water storage tank and is provided with a pipe 35 for the outlet of steam and from which hot water may be tapped by means of a valve 37.

**313,916. Compagnie Nationale des Radiateurs.** June 19, 1928, [Convention date].

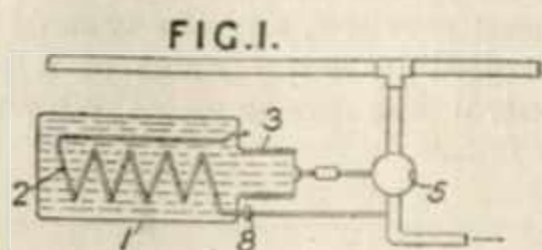

*Heating vehicles.*—In a heating system for railway vehicles, an auxiliary radiator is placed outside the vehicle and is fed by a branch conduit, the temperature of the auxiliary element acting automatically to control the heating medium for the vehicle. The auxiliary radiator 1 contains a non-freezing liquid which is heated by a pipe 2 supplied from the delivery side of the control valve 5. The expansion of the liquid in the radiator 1 acts through a bellows 3 to control the valve 5. The supply of steam to the pipe 2 is regulated at 8 so that the heating effect combined with the cooling of the radiator controls the valve 5 to give a temperature somewhat higher than desirable in the vehicle, the actual temperature being controlled as desired by passengers or otherwise. A modification is described in which the external radiator controls the air supply to the furnace of a boiler, which supplies hot water to the radiators.

**314,165. Foy, F.** April 21, 1928.

*Thermostats.*—A thermostat 14 for controlling an electric water heater is protected for a portion of its length from contact with the liquid by a casing 15 filled with air or other gas at any pressure.

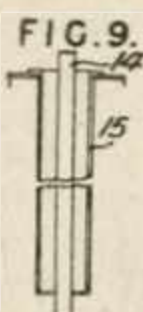

**314,354. Naamlooze Vennootschap de Nieuwe Isoleer Maatschappij de Nim.** June 25, 1928, [Convention date].

*Nonconducting coverings for heat and sound.*—As an intermediate layer between parquet slabs and concrete floors, walls, ceilings, and the like, plates of cork are used which are provided with an apertured core of wood, the upper and lower sheets of cork being united through the apertures. Preferably the cork slabs will be cemented to the concrete floor and the parquet slabs glued and nailed on to them. The core may be treated with bitumen to insulate it against moisture. Fig. 2 illustrates a cork block with a single core 2 furnished with apertures 3. Fig. 3 illustrates a double block made by applying pressure to superposed layers

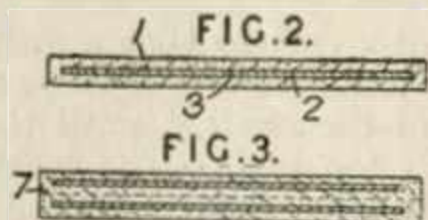

of cork and wood in a mould; the block being sawn along the line 7 to produce two single blocks of the kind shown in Fig. 2.

**314,368. Soc. l'Auxiliaire des Chemins de Fer et de l'Industrie.** June 26, 1928, [Convention date]. Addition to 313,481.

*Steam traps.*—The plant claimed in the parent Specification is modified by forming the tube 2, containing the valve 5 for controlling the discharge of heated water from the heater 1 to the receptacle 7 as a U-shaped tube one branch of which opens into the bottom of the heater while the other branch 3<sup>a</sup> opens into the heater above the highest level of water therein. The valve &c. is disposed in one of the branches so that its upper face is directly subject to the pressure of steam while its lower face is subject to the steam pressure increased by the pressure corresponding to the weight of any water which may be contained in the tube 2. Any condensate collecting in the tube 3<sup>a</sup> is discharged either automatically through an opening 63 when the valve is in its lower position or by hand through a suitable cock.

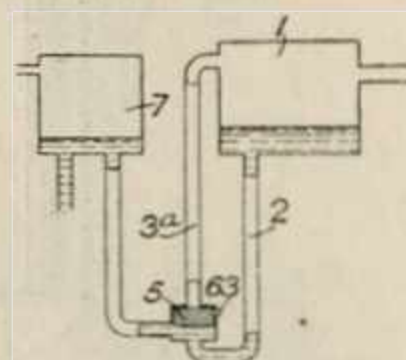

**314,554. Barker, A. H.** Dec. 30, 1927.

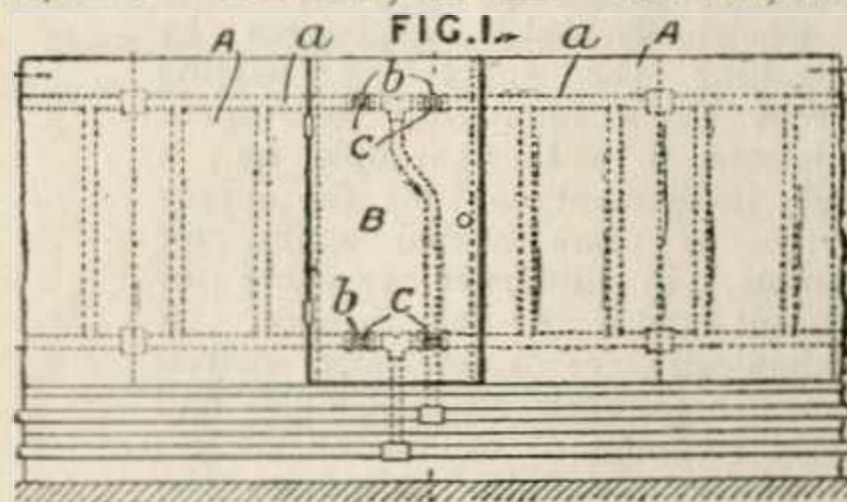

*Radiators.*—In heating devices for buildings of the kind in which a flat radiating plate A is maintained at a relatively low temperature by the circulation of hot fluid through passages a in or in contact with it, or by electric heaters in such passages, dummy plates B of similar external appearance are provided to cover the spaces occupied by valves, taps, or switches C. The dummy plates can be secured by screws to lugs or flanges on the adjacent plates, provision being made for expansion, or they may be arranged as a hinged door. The supply pipes or electric conductors may be arranged either outside or inside the skirting board which forms part of the plates. The heating units may be arranged vertically above one another, in which case the dummy plate is arranged at the bottom. The radiator plates are also applicable for cooling purposes.



314,645. **Brooke, R. G., and Holden & Brooke, Ltd.** May 12, 1928.

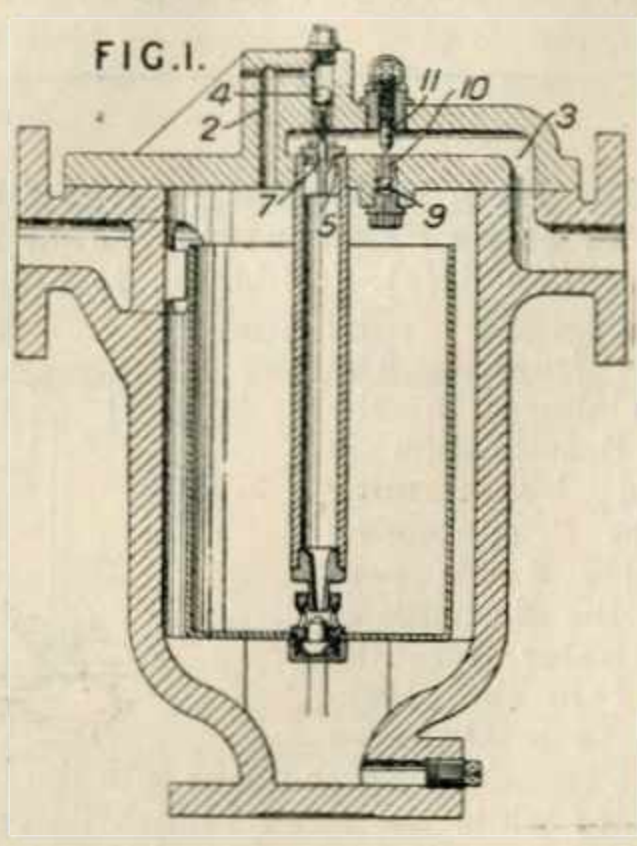

*Steam traps.*—In a steam trap of the bucket or float type, a valve 5 in the discharge passage is adapted to lift a pin 7 which unseats a ball valve 4, so that any air in the trap is discharged through the passage 2 to the outlet 3, without

passing through the water discharge valve. A valve 9 is adapted to open when the trap is not under pressure, and to close when a certain pressure has been reached, and the area of the passage 10 is controlled by adjustment of a screwed pin 11, to control the pressure at which the valve closes.

314,731. **Brewin, E.** Sept. 21, 1928.

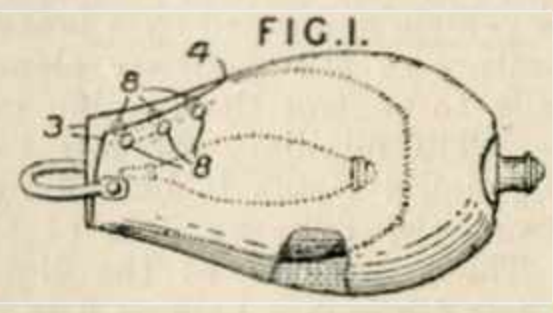

*Hot-water bottles.*—In a flexible hot-water bottle provided with an internal pocket for an infant's feeding bottle, the opening 3 for the bottle extends completely across the end of the bottle and along an edge to the point 4. The opening is closed by press stud fastenings 8 secured to the united edges of the pocket and the water container.

314,774. **Birmingham Electric Furnaces, Ltd., and Lobley, A. G.** March 28, 1928.

*Thermostats.*—In systems for automatically controlling the temperature of electrically-heated appliances by controlling the supply of heating current by a regulating instrument connected to a thermocouple &c., a single instrument controls the supply to two or more heated zones, for example, to different furnaces or different zones of one furnace. A mechanically or electrically driven controller connects thermocouples and supply switches at each zone successively for a definite period to the instrument, which then actuates the switch of a zone according to the temperature there at the period of connection. The controller may comprise switches actuated by cams on a shaft  $g$  slowly rotated by a motor  $g^1$ . Cams  $j^1 - - j^3$  connect thermocouples  $f^1 - - f^3$  at the zones  $a^1 - - a^3$  successively to the instrument control circuit  $n^1, n^2$ . Cams  $k^1 - - k^3$  connect the control coils  $n^1, n^2$  of supply switches  $d^1 - - d^3$  to a control relay  $q$  the coil of which is in the circuit  $o^1, o^2$  containing the instrument contacts. This circuit may be supplied through a voltage-reducing transformer  $p$ . Each coil  $r$  is connected to the relay  $q$  after the corresponding thermocouple has been connected to the instrument and the corresponding switch  $d$  is closed or opened according as the temperature at the zone is too low or high. Cams  $m^1 - - m^3$  control the circuits of locking switches  $e^1 - - e^3$  mechanically connected to the switches

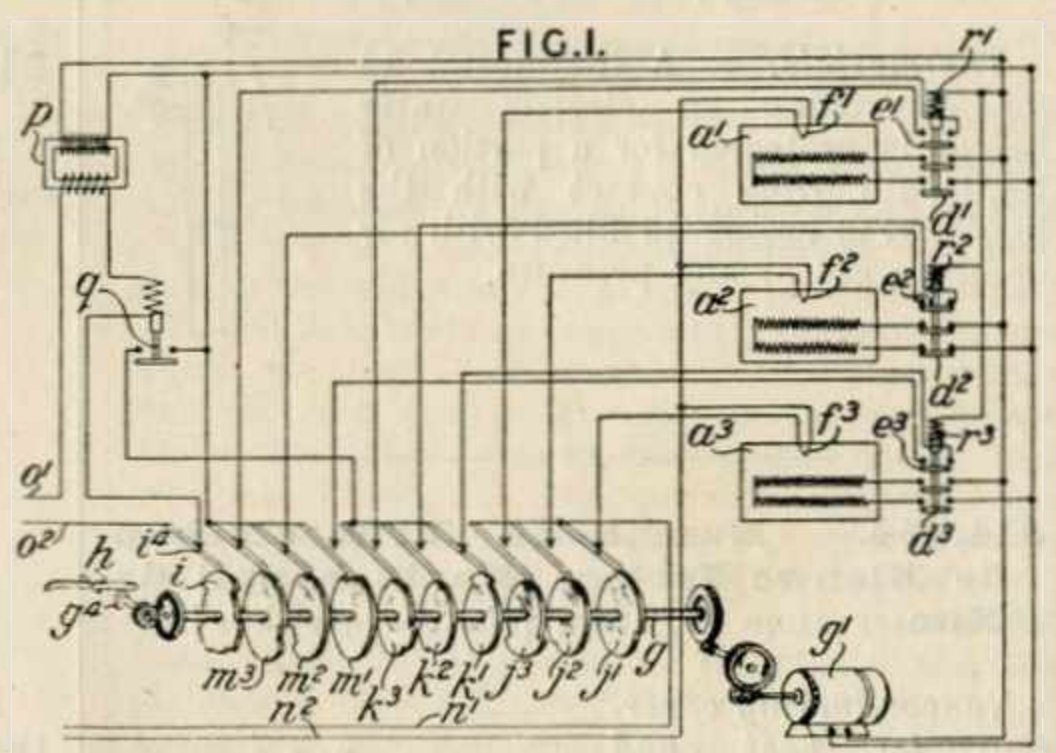

$d^1 - - d^3$  so that a switch  $d$  when closed remains closed for one or more nearly complete revolutions of the shaft  $g$  until the temperature at the zone is too high. The locking switches  $e^1 - - e^3$  may be electrically operated from the switches  $d^1 - - d^3$  instead of mechanically connected thereto. If the instrument is of the type in which the control contacts are operated on depression of a pawl  $h$ , a cam  $g^4$  rotated from the shaft  $g$  at an increased speed operates the pawl  $h$ , and a cam  $i$  on the shaft  $g$  operates a switch  $i^4$  in the circuit  $o^1, o^2$  so that no current flows through the instrument contacts when they are made and broken. The cams  $g^4, i$  are omitted if the instrument is of the immediately responsive type. The Provisional Specification describes modifications in which the

controller switches for different zones are arranged at intervals around the controller, one thermocouple being connected to the instrument before the previous thermocouple is disconnected; in which all switches for one zone are operated by one cam; in which resistances are arranged in the thermocouple circuits so that different temperatures are maintained at different zones; and in which the single relay *q* is replaced by separate relays, one in each zone.

**314,827. Barrett, L.** March 29, 1928.

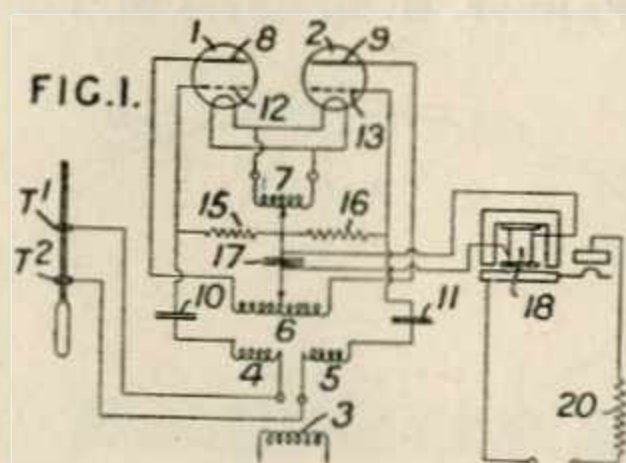

**Thermostats.** — Temperature is regulated by a thermostat which controls electric contacts in the grid circuit of a valve of a thermionic relay which actuates temperature regulating devices. The heat-sensitive element, Fig. 5, comprises a mercury thermometer having an electric contact  $T^1$  in contact with the mercury, and an electric contact  $T^2$  connected to a spiral of platinum wire  $T^3$  in the tube  $T^4$ . A piece of iron  $T^5$  carries a platinum wire  $T^6$  passing through the spiral  $T^3$ , and the temperature at which contact is made between the mercury and wire  $T^6$  is adjusted by moving the piece of iron by means of a magnet. A single phase transformer, Fig. 1, has a primary 3 with a secondary 7 centre-tapped and feeding the filaments of valves 1, 2, another centre-tapped secondary 6 connected to the anodes 8, 9, and two further secondaries 4, 5, connected through condensers 10, 11, to the grids 12, 13 of the valves, and to the contacts  $T^1$ ,  $T^2$  of the thermometer. Grid leaks 15, 16 are connected between the centre point of the secondary 7 and the grids 12, 13, and a condenser 17 between the same centre point and the centre point of secondary 6. These two centre points are also connected to an electromagnetic switch 18 controlling the circuit of an electric heater 20. The heater 20 may be used to maintain a temperature above normal, or it may be used to modify the temperature produced by a refrigerator. When the contacts  $T^1$ ,  $T^2$  are open, the filaments are energized and voltage is applied to the electromagnet 18, and the circuit of the heater 20 is completed. Rectification is effected by the valves, and only direct current is applied to the electromagnet. When the contacts  $T^1$ ,  $T^2$  are closed, grid bias is applied to the grids 12, 13, so that when the anode of each valve becomes

FIG. 5.

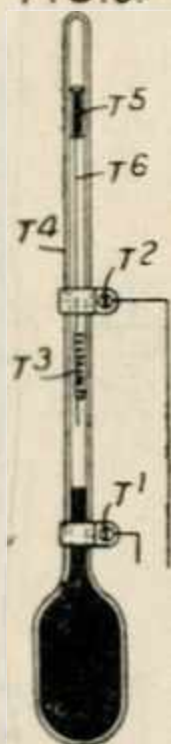

positive, its grid becomes negative. The plate current is reduced to zero, and no current flows to the electromagnet 18, so that the heater 20 is cut off. Direct current is prevented from flowing through the thermostat contacts when the grids become positive, by the insertion of condensers 10, 11. A modified relay circuit is described, Fig. 2 (not shown) in which only one thermionic valve is employed.

**314,853. Mautner, I.** July 3, 1928, [Convention date].

**Radiators.** — A radiator, in which heating of the surrounding air by convection is reduced, consists of vertical tubular elements *c* connected to horizontal headers, and provided with vertical ribs *a*. The elements *c* are bi-convex in cross section, and the ribs *a* may be on both sides or only on that side remote from the wall *f*. Adjacent elements are placed edge to edge so that enclosed air spaces are not formed. The depth of the ribs may decrease towards the edges of each element, or they may be placed radially.

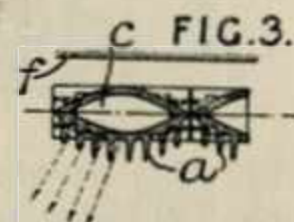

**314,996. Askania-Werke Akt.-Ges. vorm. Centralwerkstatt Dessau und C. Bamberg-Friedenau.** July 7, 1928, [Convention date].

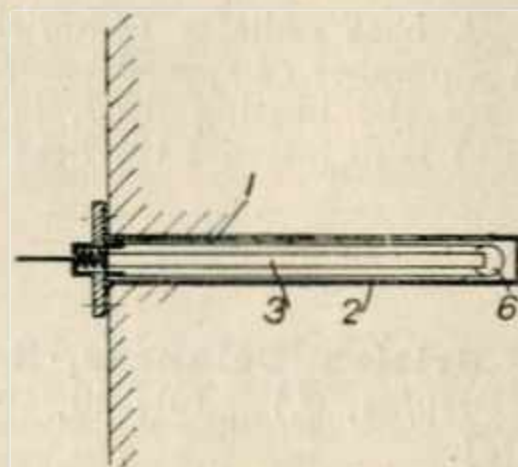

**Thermostats.**—A heat sensitive device for operating an indicating, recording, or regulating device, is, for facilitating replacement provided with a protective tube 1 which can be fitted into an opening in the container. The thermal element is of small heat capacity and comprises a thin steel band 2 passing over a support 6 and secured at its two ends. The support 6 is carried by a rod 3 of material such as quartz having a small expansion, which transmits any change in length of the band 2 to the device operated by the thermal element.

315,042. **Carnegie, J. C.** May 9, 1928.

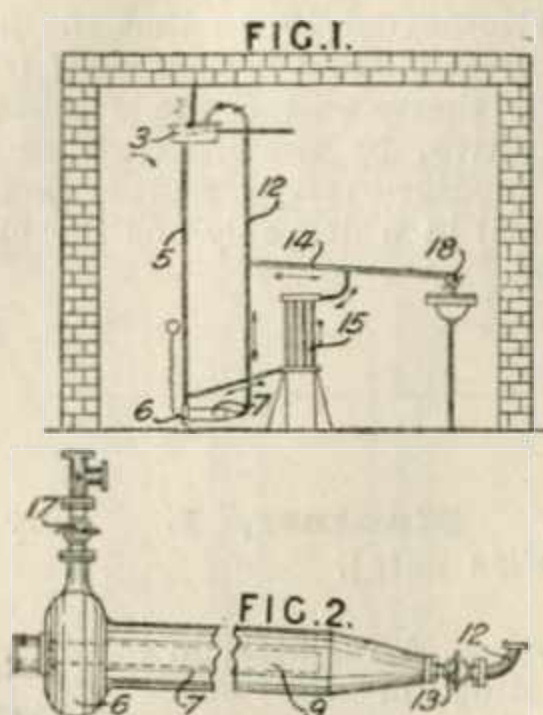

*Heating buildings.*—Water is supplied from a tank 3 through pipe 5 to the enlarged end 6 of a chamber 7 into which an electric heater 9 projects. The heated water passes into an expansion pipe 12 having a branch 14 leading to a radiator 15 and to a draw off tap 18. Taps 13, 17, are provided at the ends of the heater.

315,067. **Dennison, W. E.** June 6, 1928.

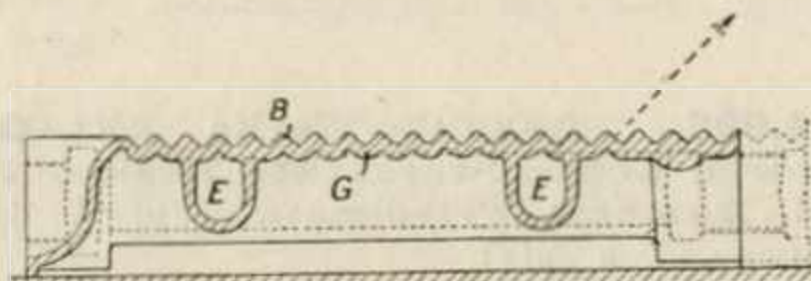

*Radiators.*—A heat radiator comprising a flat plate G with a number of spaced passageways E at the back for the heating fluid, is fluted or corrugated as at B to increase the heat radiation.

315,280. **British Celanese, Ltd.**, (Assignees of *Dreyfus, C.*) July 10, 1928, [Convention date].

*Nonconducting coverings for heat and sound.*—Cellulose esters or ethers such as cellulose acetate, formate, butyrate, propionate, or ethyl, methyl, or benzyl cellulose are employed in the form of fibres for heat and sound insulation. Suitable fibres are those of the order of 1—4 denier produced from a solution of cellulose acetate 1 part in acetone 3 parts by the usual methods. The fibres may be 1—5 inches in length and may be fluffed by agitation or blowing with air, and they may be subsequently treated by crinkling with boiling water. The fibres may be applied directly to the article to be insulated, or may be contained in jackets, and may be employed for insulating pipes, rooms, aircraft cabins, portable jars, refrigerators, and the like.

315,299. **Rheinhold & Co. Vereinigte Kieselguhr-und Korkstein-Ges.** July 11, 1928, [Convention date].

*Nonconducting coverings for heat and sound.*—In heat and sound insulation consisting of layers of air with separating walls, the walls are composed of comparatively strong and cheap metal such as iron or tin-plate to which metal foil having little radiating capacity, e.g. aluminium, is applied. The foil may be on one or both sides of the metal wall and may be wholly or in part stuck to the metal wall.

315,555. **Palmer, S. L.** June 22, 1928.

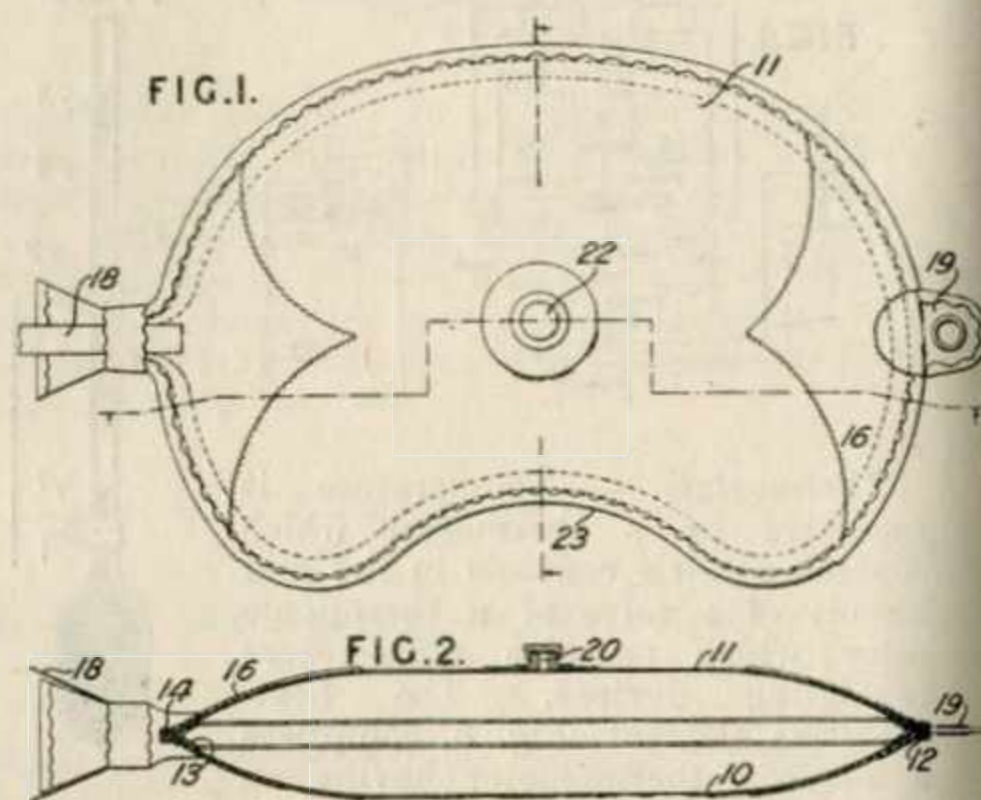

*Hot-water bottles.*—A hot-water bottle which incorporates the features of a fountain or cushion syringe comprises top and bottom flexible walls 11, 10, e.g. of rubber, or oval shape but with one concave edge 23. The edges are brought together to form a flange 12 and are reinforced by a strip 13 internally, and by shields 16 externally at the two ends. A covering strip 14 is finally applied externally around the edge. A filling opening 18 and suspension tab 19 are provided. A nozzle-supporting nipple 20 is provided on the upper wall, at a point slightly nearer the front edge 23 than the rear edge, and a cap 22 is employed when the appliance is used as a hot-water bottle.

315,712. **Raymond, F. I.** July 16, 1928, [Convention date].

*Heating buildings.*—A heating system for buildings is controlled in accordance with the temperatures of the space heated, the heating medium, and the outside air. The furnace of a hot-water boiler 10, Fig. 1, has the ash-pit door and dampers controlled by a motor 11. A room thermostat 16 may have manual or time adjustment for night and day operation, and may have low and high temperature contacts 17, 18 and a

movable contact 19. Another thermostat 20 has low and high temperature contacts 21, 22, and a movable contact 23 operated by a Bourdon tube 24 controlled by a bulb 27 in the boiler, and a bulb 28 outside the building or responsive to outside temperature changes. As an example, the heat output may be more than is necessary with the water at 170°F. and with an outside temperature of 0°F., and the thermostat 20 may be set to operate at a water temperature between 160°F. and 170°F., the outside temperature being 0°F. or at a lower water temperature if the outside temperature is higher, the effects of the bulbs 27, 28 being added together. The thermostat 16 may be set to operate between 70°F. and 72°F. Fig. 1 shows the position at starting up, both thermostats being on their minimum contacts. When the boiler water reaches its maximum point, contacts 22, 23 are closed and the motor is controlled

thermostat 20 is above the minimum, i.e., on contact plate 45. The fire is also retarded if the thermostat 16 remains on its minimum while the thermostat 20 reaches the high temperature contact 22. Similarly, either thermostat can accelerate the fire independently. The application is also described to hot air supply systems, (Figs. 5 and 6, not shown), to a hot water system

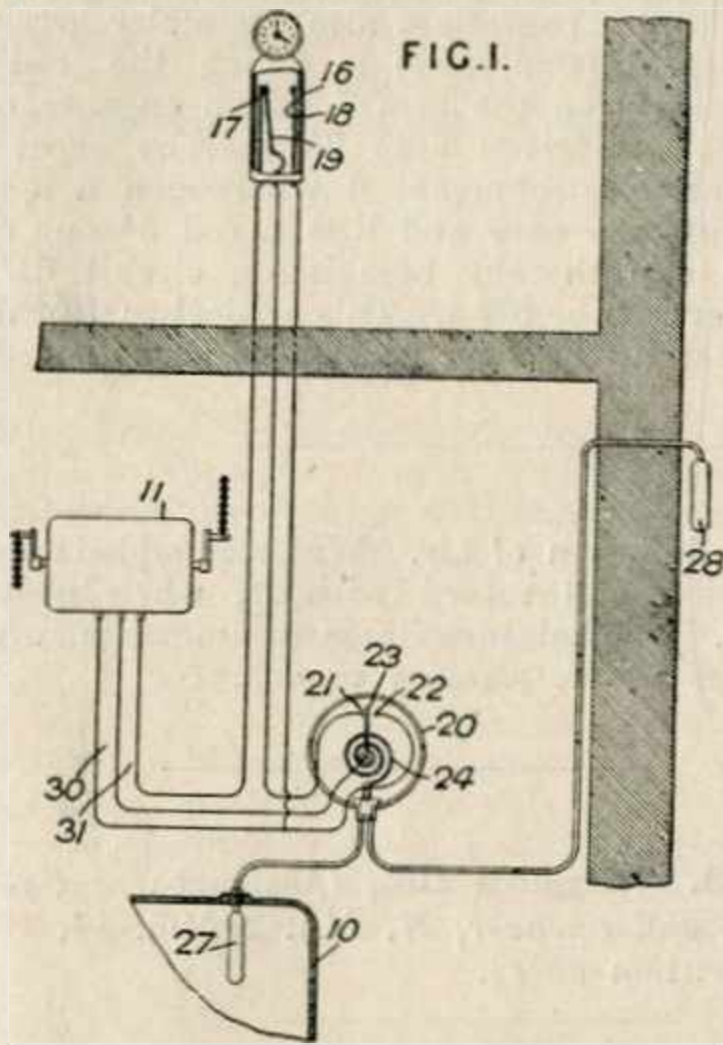

through circuit 30, 31 to retard the fire. A similar action would take place if the contacts 18, 19 were first completed. The thermostat 20 accelerates the fire when the water cools to 160°F. and contacts 21, 23 are closed, provided that the room temperature has closed the contacts 17, 19. Thus, either thermostat can retard the fire independently, but both thermostats must be at or below their minimum points to accelerate the fire. The same method may be applied (Fig. 2, not shown) to the control of the oil fuel supply. In another modification, Fig. 3, the connections are such that either thermostat 16, 20 can independently accelerate the fire, but both must function to retard it. A quick heating up is thus ensured, but overheating of the liquid is not prevented by this device. In another modification, Fig. 4, the two systems are combined, and an additional contact plate 45 is provided on the thermostat 20, on which the arm 23 rests except in extreme positions. The connections are such that the fire is retarded when the room thermostat completes the contacts 18, 19 and the

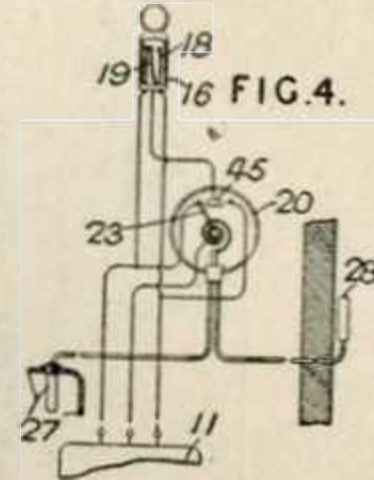
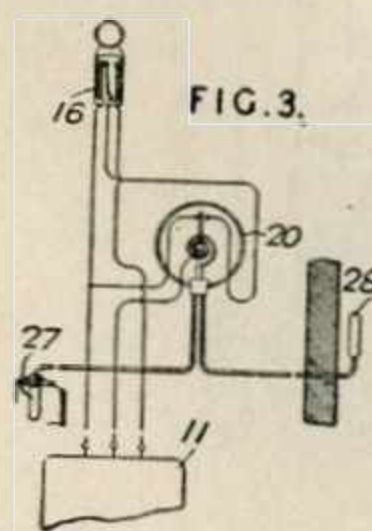

heated by multiple burners controlled separately by thermostats in different rooms (Fig 7, not shown), and to the control of the effective radiating surface in a steam or vacuum system (Fig. 8, not shown).

The Specification as open to inspection under Sect. 91 (3) (a) describes also the application to a vacuum or vapour system (Fig. 5, not shown). This subject-matter does not appear in the Specification as accepted.

**316,202. Klerk, G. T. de.** July 25, 1928, [Convention date].

*Nonconducting coverings for heat.*—A non-conducting covering for pipes comprises an inner asbestos layer 1 which may or may not be provided with air cells, a number of layers of plain and corrugated cardboard 6 - - 13 arranged alternately, and an outer paper or like layer 4. The covering is split longitudinally to place around the pipe and the outer layer is then glued on with an overlapping portion. The cardboard or paper is previously treated with non-conducting substances such as tar and resinous substances. When the asbestos layer is provided with air cells, it is made thicker.

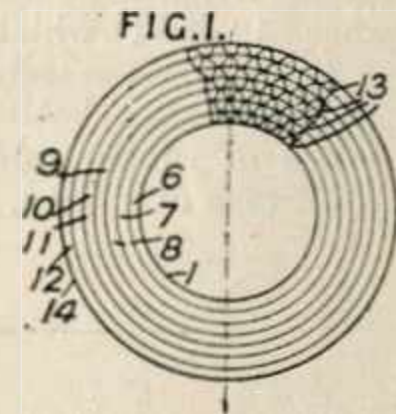

**316,682. Fabrique Nationale d'Armes de Guerre.** Aug. 2, 1928, [Convention date].

*Thermostats.*—The temperature of an oven 2 is regulated by means of a thermal switch comprising a contact arm 7 which is moved by a thermal element 2<sup>a</sup> between two contacts 7<sup>a</sup>, 7<sup>b</sup> which are in the form of screws driven inde-





ULTIMHEAT<sup>®</sup>  
VIRTUAL MUSEUM

dependently of each other by clockwork so as to vary the temperature at which the oven is maintained. In the arrangement shown in Fig. 1, engagement of the contacts 7, 7<sup>k</sup> closes a circuit to the electromagnet 6 which attracts its armature 5<sup>a</sup> and thereby not only breaks at 5<sup>k</sup> the

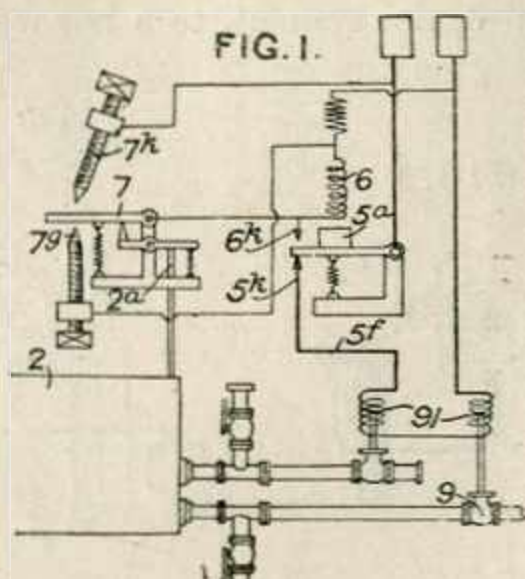

circuit 5<sup>f</sup> to the actuating-electromagnets 91 of valves 9 controlling the supply of air and gas to the oven, but closes at 6<sup>k</sup> a retaining circuit which keeps the magnet energized until the arm 7 moves into engagement with another clockwork-controlled contact 7<sup>o</sup> and short-circuits the electromagnet. The thermal element 2<sup>a</sup> may comprise

(Fig. 3, not shown) a rod of silica enclosed in a tube of steel consisting of iron, silicon, manganese, carbon, copper, nickel and chromium in specified proportions. When heated the tube expands more than the rod, and the latter or an extension of it moves downwards. In Fig. 1, the rod bears on an intermediate lever which bears on the contact arm 7.

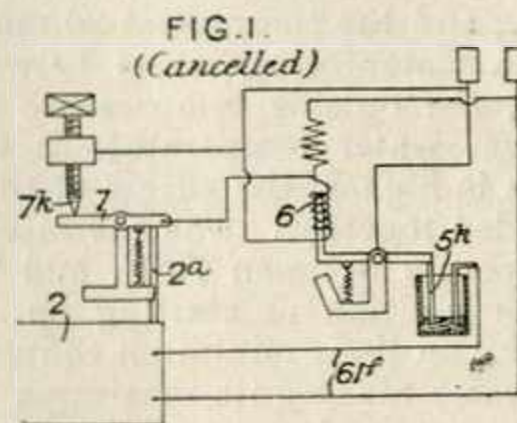

The Specification as open to inspection under Sect. 91 (3) (a) comprises also a simpler arrangement, Fig. 1 (Cancelled) in which the rod 2 bears directly on the arm 7 which engages only one clockwork-driven stop 7<sup>k</sup> thereby short-circuiting an electromagnet 6 whereupon a spring pulls down the core and lifts a rod 5<sup>k</sup> out of a mercury cup thereby breaking a circuit 61<sup>f</sup> to the heaters of the oven. This subject-matter does not appear in the Specification as accepted.

**316,727. Thomas, G.** May 31, 1928.

*Hot-water bags.*—A liquid reservoir 12 which forms part of a surgical irrigating appliance 10 and which may be used separately as a hot-water bottle is made of rubber and in the shape of a bean.

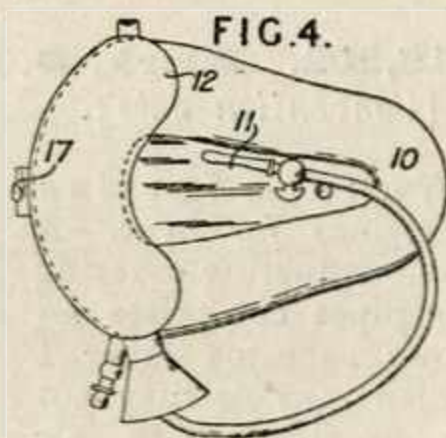

for the admission of air. Water is added to the composition and mixed with it, when heat is required. The mixture liberates ammonia, which stimulates the respiratory organs.

**317,363. Upson Co.,** (Assignees of Upson, C. A., and Spencer, H. M.). Aug. 14, 1928, [Convention date].

**316,878. Hallam Corporation,** (Assignees of Baysinger, V. R.). Aug. 4, 1928, [Convention date].

*Heating by chemical action.*—A composition for generating heat by the addition of water, applicable for heating pads, comprises a mixture of crushed cast iron, crushed carbon steel, and a salt or salts. A preferred mixture contains crushed cast iron 95 lb., crushed carbon steel 5 lb., Epsom salt 0.5 lb., sodium chloride 0.5 lb., ammonium chloride 0.25 lb. The composition is placed in a canvas bag 2 which is inserted in a waterproof cover 4 having openings 5

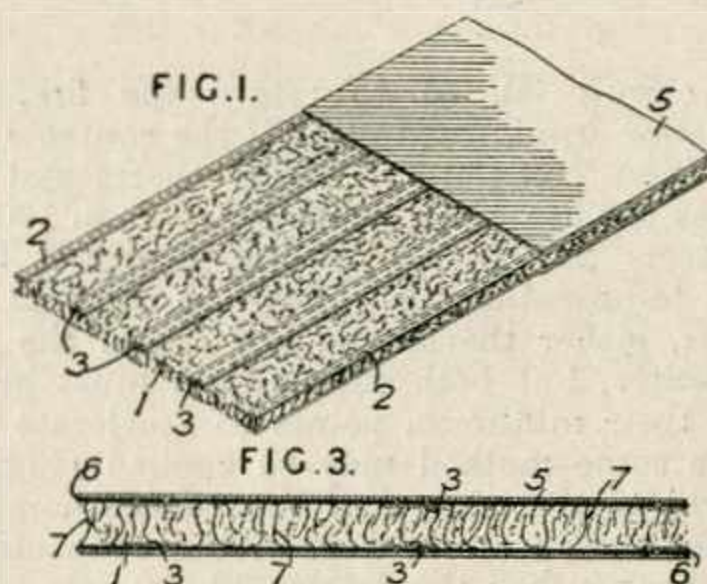
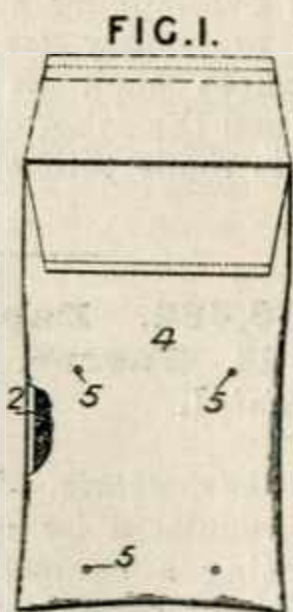

*Nonconducting coverings for heat and sound.*—Composite heat and sound insulating material comprises a loosely felted bat of vegetable fibres of one kind interspersed with stronger and longer vegetable fibres of different nature and material, such as short cotton fibres interspersed with jute fibres. Covering sheets of flexible material may be secured by adhesive to each side of the bat. The material comprises a loosely felted bat 1,

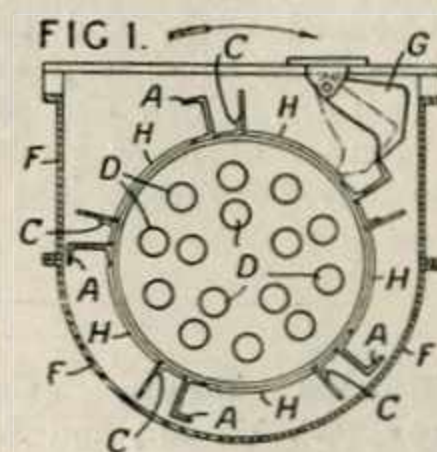

Fig. 1, sewn to which are thin strips 2, 3 of flexible material such as paper, with sheets 5 of paper or other material secured to each face by adhesive, preferably asphalt. The bat 1 is composed of damaged or waste cotton, with a proportion of from 10 to 30 per cent of jute fibres,

which as shown at 7 in Fig. 3, serve to bind the shorter fibres together and unite the upper and lower covering sheets 5 by being secured thereto by the adhesive 6. Specification 306,559, [Class 109, Ropes &c.], is referred to.

**317,581. Simon, W. G., and Simon, F. R.** June 25, 1928.

*Heating granular material.*—Pivoted hammers G on a fixed part of the apparatus loosen granular material being heated in a semi-circular trough F in which revolves a drum containing tubes D and carrying shovels or angles C. Projections A on the drum lift the hammers G which by gravity or spring pressure strike a moving part e.g. a protection plate H on the drum. Specifications 3660/81, [Class 34, Drying], 18750/07, [Class



55, Gas manufacture], and 6347/13, [Class 34 (ii), Drying systems &c.], are referred to.

**317,640. Geipel, Ltd., W., and Pell, W. Guy.** Aug. 20, 1928. No Patent granted (Sealing fee not paid).

*Steam traps.* — In a steam trap of the kind in which a valve is operated by the bending of tubes 1, 3 having different expansion coefficients, one or more of the tubes 3 carries a threaded collar secured between members 5, 6, which are screwed into the frame 2. Fluid tightness is secured by a V-groove in the member 6 into which the ends of the tube and collar are received. The joint is thus rigid with the frame to allow bending of the tube to take place. Specifications 13811/10; and 10989/12,

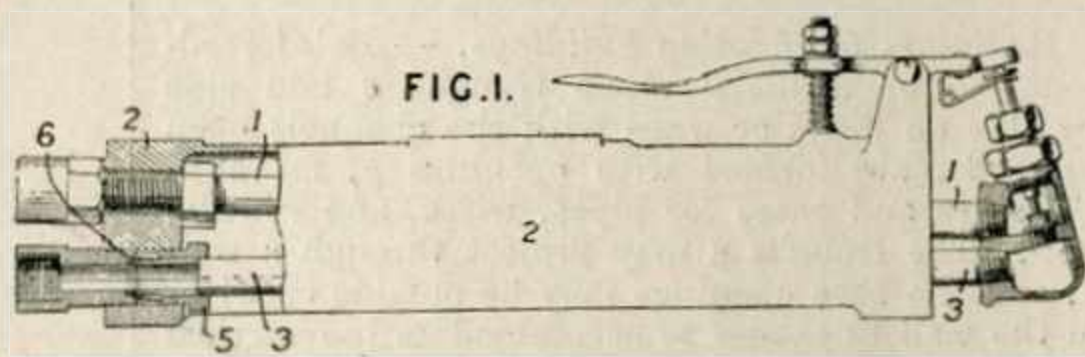

[Class 99 (i), Pipes and tubes, Joints &c. for], are referred to.

**317,678. Schmidt, E., and Dyckerhoff, E.** Nov. 3, 1928.

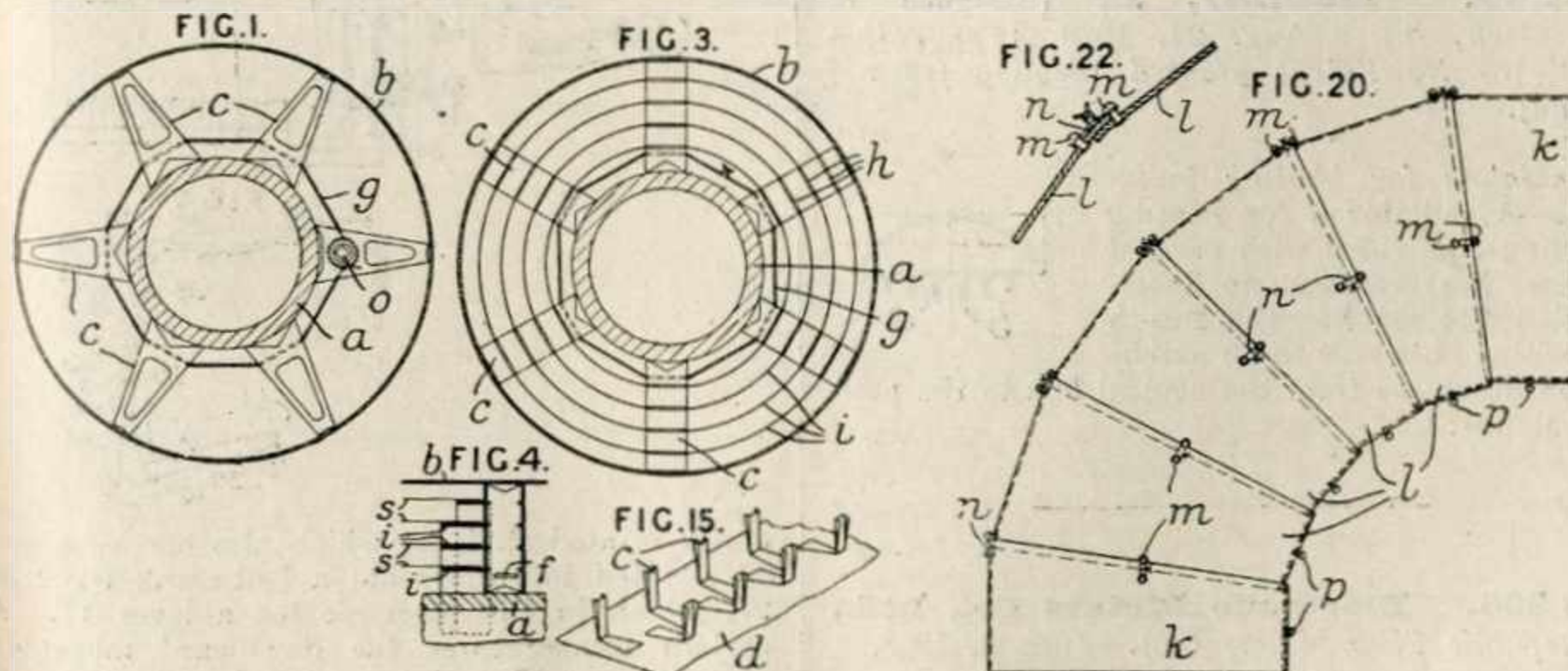

*Nonconducting coverings for heat.* — Objects or other flexible sheet material which is supported by a spacing structure to enclose layers of air,

and finally enclosed by a casing. A casing *b*, Fig. 1, is spaced from a tube *a* by means of members *c* having only a few points of contact with the tube *a*, and having slots *f*, Fig. 4, through which a wire or band *g* is drawn and secured by means of a tension device *o*. Flat bands *i* are inserted in slots *h* in the members *c*, and serve to support thin aluminium sheets *s* which enclose the air layers forming the insulation. Modifications are described in which the bands *g* are dispensed with, and the bands *i* retain the members *c*. In this case, each member *c* is formed in sections which engage over one another in the manner of press studs with the bands *i* and sheets *s* between. The bands are

deformed where they pass through the member *c*, to secure them. The spacing members may be formed from a metal strip *d*, Fig. 15, having tongues *c* pressed out, and such members may be applied to objects of any shape. Several other forms of spacing members are described, and all may be made of sheet iron containing 0.5 per cent of silicon, or of nickel steel containing 15-30 per cent of nickel. A suitable sectional casing for curved pipes is made from separate strips *k*, *l*, Fig. 20, which are bent into shape with their edges overlapping. A number of projecting studs *m*, *p*, are provided on the edges, to receive connecting wires *n*, Fig. 22.

**317,714. Evans Bros. (Concrete), Ltd., Honner, W. R. E., and Llewelyn, J. L.** March 13, 1928.

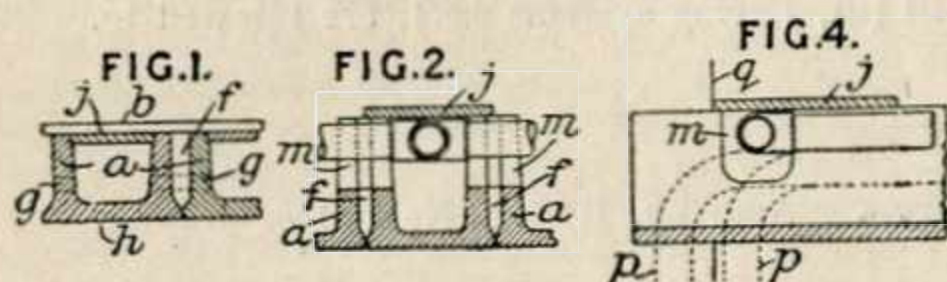

*Radiators for heating buildings.* — Reinforced-concrete or artificial stone troughs *a* laid side by side on joists or walls with the channels open upwards, are formed with openings *g*, *m*, *h* in the sides and bases for pipes, wires, and ventilation. The troughs *a* may project through a wall *q*, and the base openings may be outside or within the wall thickness to accommodate the vertical pipes *p*. The channels may be closed by tiles *j* inset in the sides or laid thereon, or the tiles may be omitted when the surface covering *b* is of sufficient strength. The spaces *f* between the troughs are filled with cement or other jointing material.

**317,799. Mautner, I.,** (Assignee of *Deutsch, S.*) Aug. 22, 1928, [Convention date]. No Patent granted (Sealing fee not paid).

*Radiators for heating buildings.*—A radiator *a* for heating buildings, provided with parallel vertical fins according to Specification 314,853 has the fins *b* projecting outwards to an extent which decreases from the central fins to the peripheral fins.

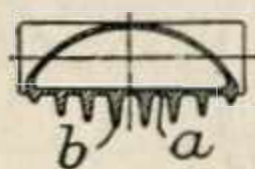

**318,308. Electroflo Meters Co., Ltd.,** (*Republic Flow Meters Co.*) June 5, 1928.

*Thermostats.* — A device for controlling temperature comprises a temperature-responsive

index 11, Fig. 7, a guide member 40 the position of which is dependent on the position of the index, a mechanically-reciprocated member 39 which moves up and down on one or other side of the member 40 according to the position of the latter, and a switch or valve controlling member 50 the position of which is determined by the path of the member 39. The member 39 hangs from a crank 36 on a continuously or intermit-

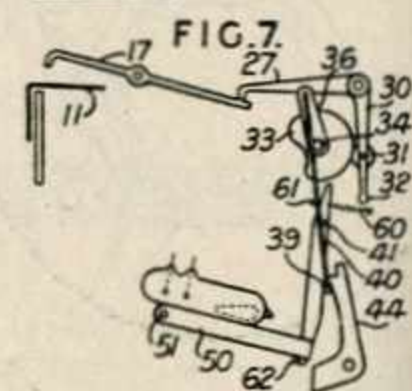
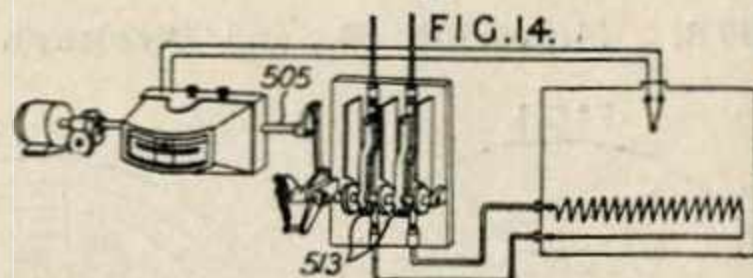
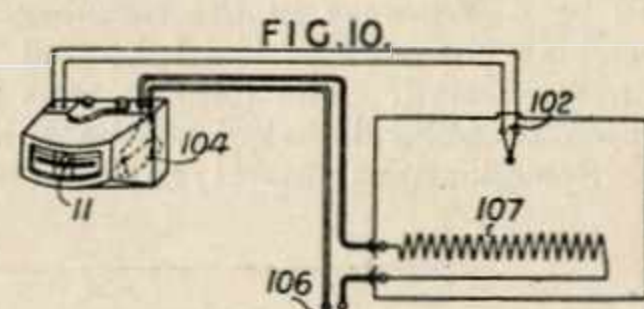
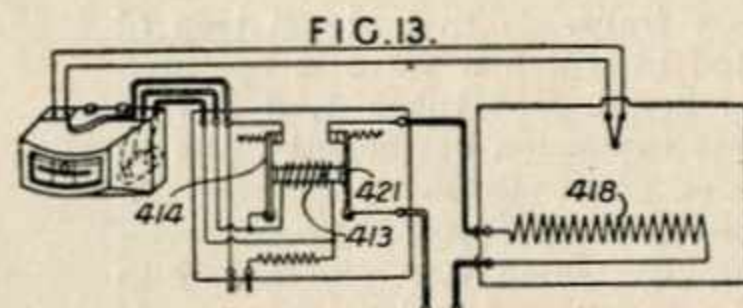

tently rotated shaft 34 which also carries a cam 33 adapted to reciprocate a bell-crank lever 30, 27, which in turn reciprocates a lever 17. At certain temperatures the downward movement of the lever 17 is intercepted by the index 11 and when this is the case, the member 40 is held by its spring 60 in the position shown in Fig. 7

with its lower end against a stop 62. The member 39 moves up and down on the right hand side of the member 40 and the member 50 remains in the position shown. Should, however, the temperature pass a certain point, the index 11 no longer restrains the lever 17 and accordingly when the member 39 is in its lowest position, a roller 31 on the lever 30 moves into the hollow portion of the cam and the lower end 32 of the lever presses the member 40 about its pivot 41 till its upper end engages the stop 61. The member 39 now moves up the left hand side of the member 40 and lifts the switch member 50 into its "on" position in which it is held latched by a catch 44 and remains so latched till the temperature changes so that the index 11 again engages the lever 17. When this happens the first upward movement of the member 39 on the right hand side of the member 40 will move the catch 44 out of engagement with the member 50 which will then fall again into the position shown in Fig. 7. A recording device for making a permanent record of the temperature may be associated with the index 11 (Fig. 9, not shown).

The member 50 which controls the supply of heat may carry a mercury switch as shown in Fig. 7 or the rotation of its shaft 51 may operate a switch or valve in other ways. The temperature-responsive index 11 may be a needle connected to the armature of a galvanometer connected to a thermo-couple associated with the

furnace &c. to be regulated. Fig. 10 shows a simple system of temperature regulation, the thermo-couple 102 causing the actuation of the needle 11 which in turn by means of the device described above controls the position of the mercury switch 104 which connects or disconnects a heating unit 107 to or from the source of supply 106. In a modification (Fig. 11, not shown), the mercury switch closes a circuit to an electromagnet which operates valves controlling the supply of fluid to a burner or injector. In another modification, (Fig. 12, not shown) the mercury switch closes a circuit to a relay controlling the heating circuit. Fig. 13 shows a system in which the mercury switch has a pair of contacts at each end of the tube. Connection of the one pair of contacts by the mercury closes a circuit to an electromagnet 413 which thereupon attracts two armatures 414, 421, the former closing a maintaining circuit and the latter closing the circuit to the heater 418. When the mercury tube is tilted into its other position, the winding 413 is short-circuited, the armatures fall away and the heater circuit is opened. Fig. 14 shows an arrangement in which the mercury switch is dispensed with, the shaft 51 of the member 50, Fig. 7, being prolonged at 505 and operating switch arms 513 through dead-centre quick-action mechanism. In a modification, (Fig. 15, not shown) the shaft operates fluid-controlling valves.

318,574. Church, G. T. June 6, 1928.

*Thermostats.*—Relates to apparatus employing a heating resistance A tapped at different points which are connected to contact studs B cooperating with an arm C connected to one of the supply leads and consists in the provision of a make and break device D<sup>1</sup> operated by a temperature responsive element to control a part of the heating resistance. The apparatus is particularly intended for use in incubators. In Fig. 3 a second contact arm C<sup>2</sup> is provided, mechanically connected to the arm C but electrically insulated from it. The arm C<sup>2</sup> is connected to the supply lead when the switch D<sup>1</sup> closes. An extra heating resistance A<sup>2</sup> may be connected at one end to a knife contact A<sup>4</sup> which engages with an extension C<sup>0</sup> on the arm C when the latter is moved to reduce the main resistance to a minimum. Additional dummy contact studs B<sup>x</sup> are provided so that the arm C<sup>2</sup> can be moved on to the stud appertaining to the maximum resistance. In a modification the resistance A constitutes an auxiliary element in parallel with a main heating element which is permanently in circuit. In a further modification there are three contact arms and two make and break devices. In Fig. 6

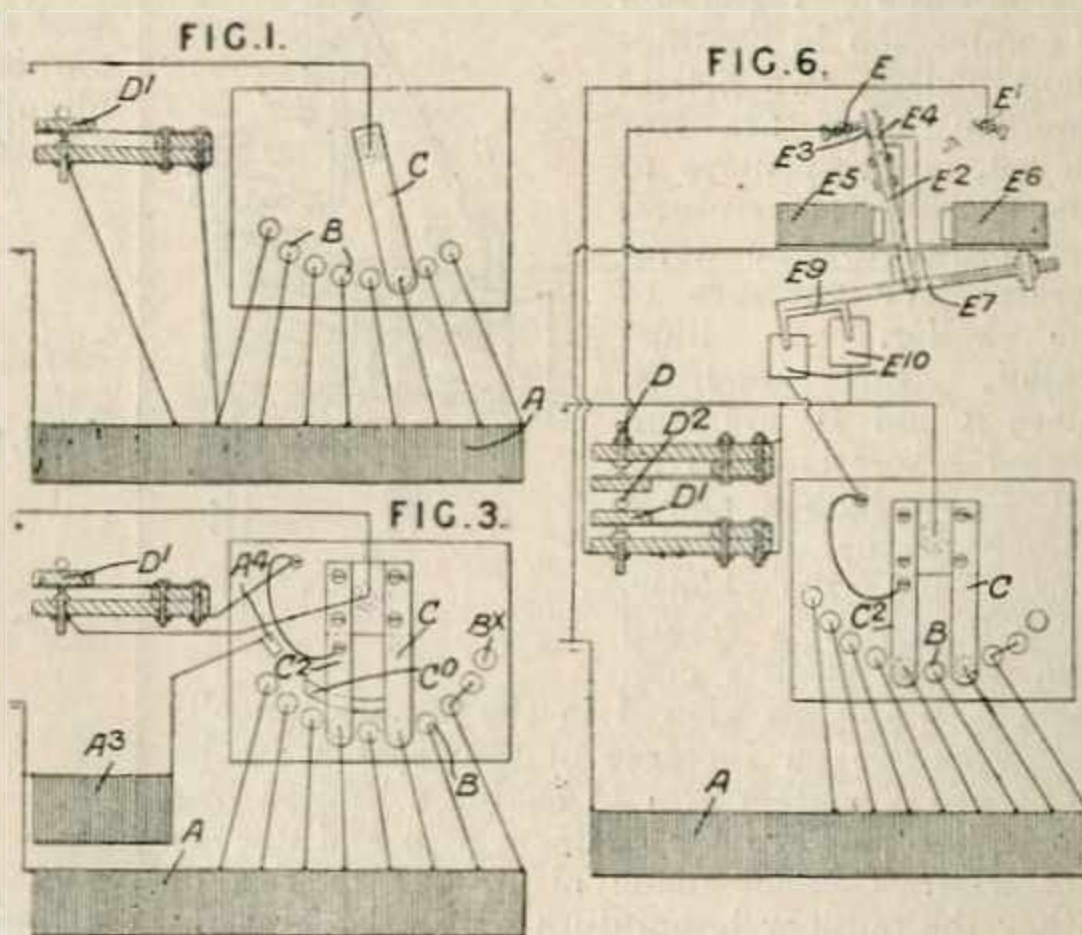

there are two make and break devices D, D<sup>1</sup> operated by a common rod D<sup>2</sup> and connected to contacts E, E<sup>1</sup>, and to the positive supply lead. The contacts E, E<sup>1</sup> are arranged on either side of a pivoted armature E<sup>2</sup> carrying contact-blades E<sup>3</sup>, E<sup>4</sup> connected to electromagnets E<sup>6</sup>, E<sup>5</sup> which are also connected to the negative supply lead. The pivot of the armature E<sup>2</sup> carries a weighted lever E<sup>7</sup> having prongs E<sup>9</sup> dipping in mercury cups E<sup>10</sup> connected to the contact arms C, C<sup>2</sup>.

318,652. **Reavell, J. A.** May 8, 1928.

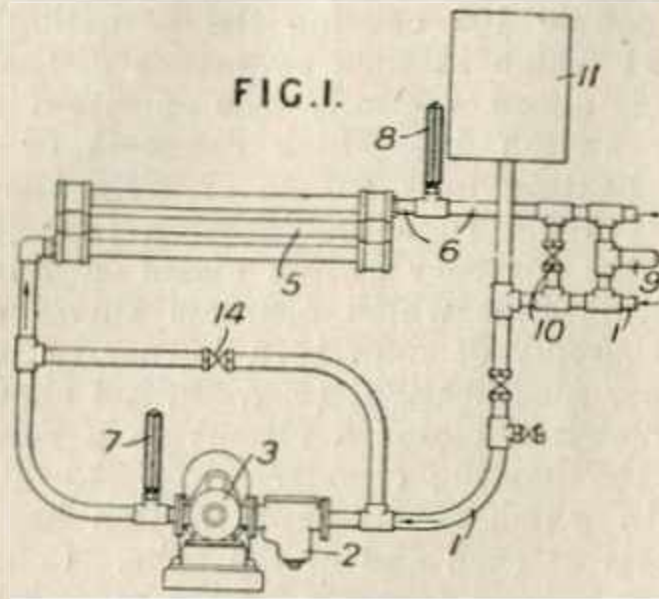

*Heating by circulation of fluids.*—Oil is circulated by a pump 3 through an electric heater 5 and a tube 6 to apparatus in which its heat is utilised, the oil being returned to the pump through a pipe 1. Bypass valves 10, 14 a relief valve 9, a strainer 2, thermometers 7, 8, and an expansion tank 11 are fitted as shown.

318,699. **Wingfield, B. T.** July 3, 1928.

*Thermostats.*—In the thermostatic regulation of combustion in heating-plant boilers, two helical Bourdon tubes are employed, one responsive to the outside temperature, the other to the temperature or pressure of the boiler. As illustrated, the Bourdon tubes 3 and 10 are connected respectively to an out-of-door bulb 1 and a bulb 8 in the hot-water flow from the boiler. Tube 3 carries a forked arm 4 with electric contacts 5, 6 and, as viewed in the Figure, uncoils anti-clockwise on increase of temperature; tube 10 carries a contact arm 11 having a limited free movement between the contacts 5, 6 and uncoils clockwise. Contact made at 5, due to rise of either the outdoor temperature or the boiler temperature, closes the boiler damper; similarly contact at 6 due to fall of temperature opens the damper. Thus, over the range of outdoor temperature provided for, the boiler temperature is appropriately controlled. The adjustable stop 7 puts a limit to the rise of boiler temperature on decrease of outdoor temperature. In the case of a steam boiler, the Bourdon tube 10 may be actuated by steam pressure. Instead of a damper, the oil or gas fuel supply or a circulating fan or pump may be controlled.

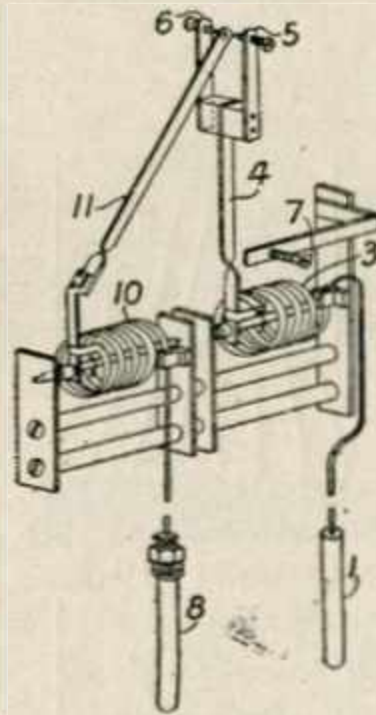

As illustrated, the Bourdon tubes 3 and 10 are connected respectively to an out-of-door bulb 1 and a bulb 8 in the hot-water flow from the boiler. Tube 3 carries a forked arm 4 with electric contacts 5, 6 and, as viewed in the Figure, uncoils anti-clockwise on increase of temperature; tube 10 carries a contact arm 11 having a limited free movement between the contacts 5, 6 and uncoils clockwise. Contact made at 5, due to rise of either the outdoor temperature or the boiler temperature, closes the boiler damper; similarly contact at 6 due to fall of temperature opens the damper. Thus, over the range of outdoor temperature provided for, the boiler temperature is appropriately controlled. The adjustable stop 7 puts a limit to the rise of boiler temperature on decrease of outdoor temperature. In the case of a steam boiler, the Bourdon tube 10 may be actuated by steam pressure. Instead of a damper, the oil or gas fuel supply or a circulating fan or pump may be controlled.

319,377. **Taylor, F. A., and Taylor, H. A.** March 22, 1928.

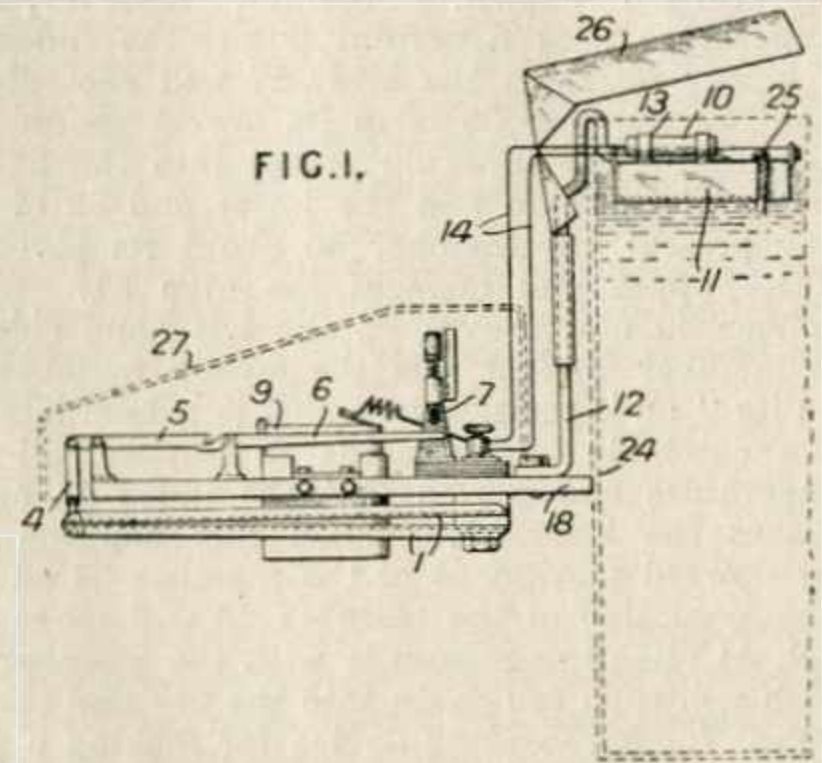

*Thermostats.*—In temperature regulating apparatus for protecting crops from frost and controlling the temperature of glass houses, garages, store house, &c., comprising a thermostatically controlled electrical circuit adapted at predetermined temperatures electrically to ignite one or more pyrotechnic fuzes or devices which light or fire one or more heating devices, the thermostat comprises two metal strips 1 spaced apart at one end and connected together at the other, lever mechanism 4, 5, 6 being provided to magnify the movement of the connected end. At the predetermined temperature the lever 6 makes contact with an adjustable screw 7 provided with a vernier temperature scale, and thus closes the circuit of a battery 9 which then fires a firework or other pyrotechnic fuze 10.

319,493. **Case, W. G.** Sept. 25, 1928.

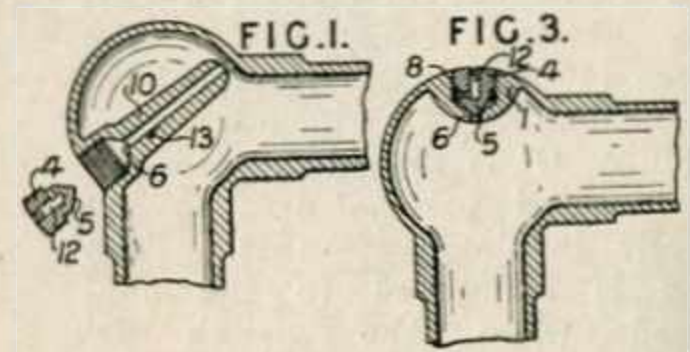

*Radiators.*—An air release valve for hot water radiators, towel rails, &c., comprises a set screw 4 in which the outlet passage 8, 12 is formed and which lies flush with the surrounding surface when its conical end 5 closes the vent 6. The threaded recess may be formed in the radiator casing 1 or in a plug screwed thereinto. In Fig. 3, it is shown in the upper part of the boss of a tubular towel rail whilst, in Fig. 1, an inclined venting passage 10, drilled through an internal projection 13, leads from the upper part of the boss to an outlet at a lower level.

**319,648. Bowran & Co., Ltd., R., and Craggs, J. W.** Aug. 22, 1928.

*Nonconducting coverings for heat.*—A heat nonconducting composition in paste form is made by adding powdered talc, and finely ground

asbestos to an emulsion of bitumen in water. The composition is especially intended for application to the surfaces of cork sheets used for heat insulating, but may also be used for coating other surfaces, such as magnesia coverings of cold storage chambers.

**319,894. Gramophone Co., Ltd., and Fernberg, E. B.** Aug. 27, 1928.

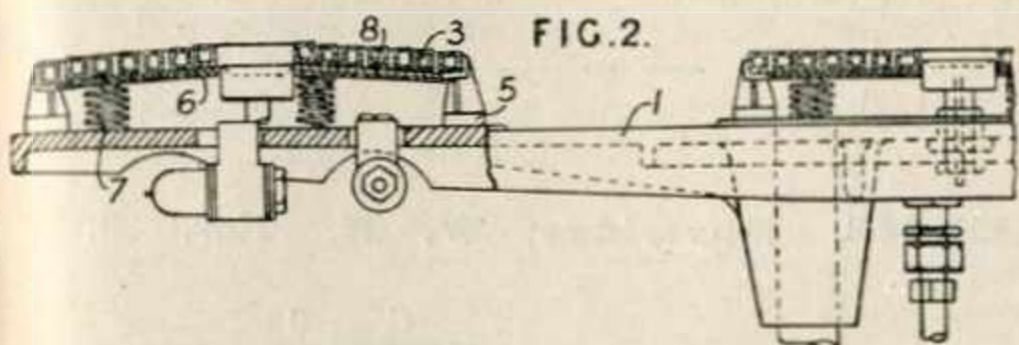

*Heating systems and apparatus.*—Means for heating bodies by surface contact comprises a tube wound into a spiral &c. which is connected at one or more points to a rigid support, the unconnected turns of the spiral being urged yieldingly upwards and movable relatively to one another to permit the unit to conform to the body to be heated. As shown, applied to the heating of book-form gramophone dies, a table 1 carries a pair of heating-units 3 formed of square-sectioned brass tubing wound into spiral form with the outer coils supported by brackets 5 while the inner ends are unsupported. Springs 7 acting through flexible plates 6 and interposed asbestos sheets 8 are provided beneath the units. The ends of the coils are connected to steam pipes. A modification is described in which the coils are supported at the inner ends. The units may be supported at both inner and outer ends or at one or more intermediate turns.

the air in the tube 3 conforms more closely to atmospheric conditions. Alternatively, a passage between the lower end of the tube 3 and the atmosphere may be provided.

**321,193. Foutz, C. R.** May 1, 1928.

*Thermostats.*—The capsule of the thermally-operated valve 43 comprises two plates 95 of spherical contour which have flat riveted edges, slidable between flanges 85 of a perforated casing having annular supporting ribs 105. The capsule contains water and air. The spindle of the valve 90 has a spider 93 and a packed piston with a pressure equalizing vent 104 and is operated by a thrust block 102 from the capsule the height of which is adjustable by a screw 98.

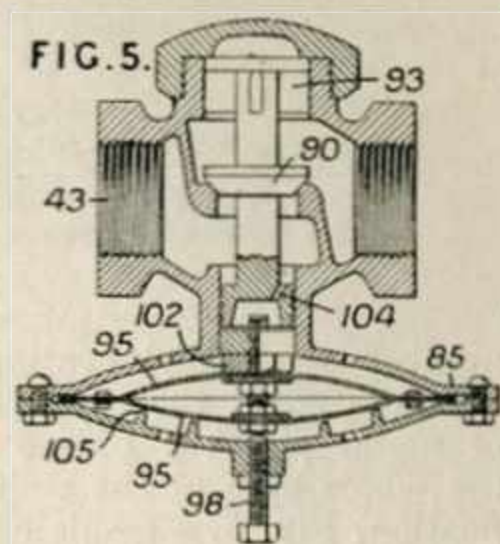

**321,287. Hoogenbemt, R. van.** Sept. 28, 1928.

*Nonconducting coverings for heat and sound.*—Plates for insulating sound and heat and auxiliary vibrations are formed of a pulp consisting of waste paper fibres mixed with longer waste flax fibres, preferably in equal amounts. The pulp is wound on a drum to the thickness desired, and is then slitted, removed, pressed, and dried. The plates may be made impermeable, for example by a coating of silicate of soda.

**320,932. Cloud, J. W., and Westinghouse Brake & Saxby Signal Co., Ltd.** July 26, 1928.

*Radiators.*—In a thermostatic regulator 2 attached to a steam heated radiator 1, an inner tubular member 3 is mounted in a threaded adjustable plug 4, and its lower end carries the steam inlet valve 6. The position of the valve is determined by the relative expansion of the tube 3 and casing 9. An open ended tube 10 is arranged in the tube 3 to cause a circulation of air through the tube 3 so that

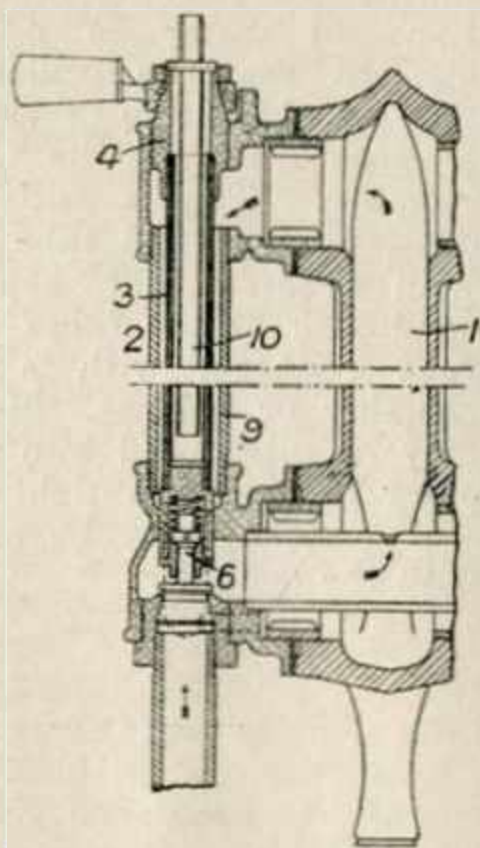

**321,450. Benham & Sons, Ltd., and Allensby, C. R.** Aug. 9, 1928.

*Radiators.*—Heating, lighting, or like coils and panels, or gas and water pipes in walls, ceilings, or floors are secured by supports attached to dowels embedded in the wall, ceiling, or floor.



The pipe *b*, Fig. 1, is arranged within a U-shaped cover *d*, and supported by a flat metal strip *c* fixed by screws *f* to dowels *e* embedded in the concrete *a*. The head of the screws *f* are flush with the surface of the strip *c*, and are accessible for removing the pipes on removing the plaster finishing layer. A single strip *c* may support a

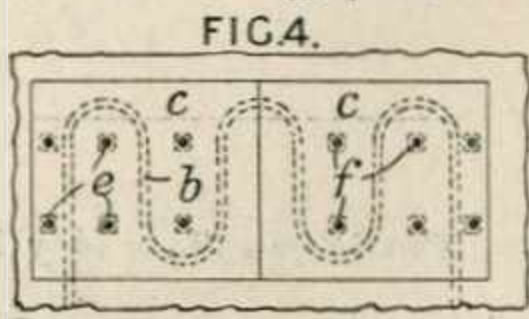
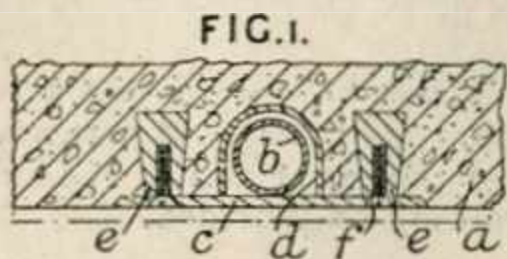

number of parallel heating pipes. In a modification, Fig. 4, the supports may be in the form of metal plates *c* butted together and covering the whole area of the coils *b*. In another modification, Fig. 5, a single cover *c* may be arranged over the whole coil *b*. Specification 307,592 is referred to.

**321,535. Homan, J. G.** Oct. 24, 1928.

*Heating by chemical action.*— A capsule for use in treating orifices of the body, and capable of applying heat with or without medication, consists of a soluble gelatine or permanent casing 2 with a cap 3, a lining 6 of a medicament vehicle containing any desired medicament, and a mass 7 of normally inert chemicals adapted to liberate heat on the addition of water, alcohol, &c., as, for example, a mixture of powdered metallic magnesium and a metallic oxide such as copper oxide. If tartaric acid and sodium bicarbonate are used, a considerable volume of gas is liberated for dilation purposes. Just prior to the insertion of the capsule, the cap 3 is lifted, water, alcohol, or other substance added to the chemicals, and the cap replaced. The chemicals react, and, when heat is liberated, the lining 6, which is preferably of cacao butter, is melted and forced through the holes 4 and 5 in the casing 2 and cap 3 respectively along with the medicament it contains, the chemicals, and any gas generated. The device may be used with a soluble lining 6, or without a lining.

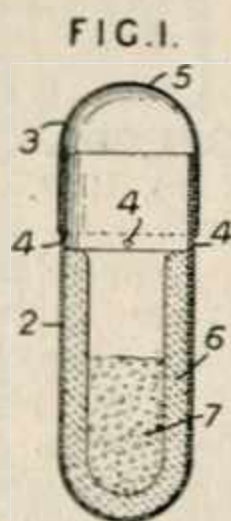

**321,564. Smith, F. D.** Nov. 15, 1928.  
*Drawings to Specification.*

*Nonconducting coverings for heat.*— Lagging cords are formed from yarns coated with fibrized caoutchouc of a vulcanizable nature. The fibrized caoutchouc is obtained by mixing cotton, asbestos, or other fibres, and rubber, guttapercha, or balata. Metallic filaments may be embodied in the cords. Specifications 269,132, [Class 109, Ropes &c.], and 303,612 are referred to.

**321,568. Partridge, W. H.** Nov. 20, 1928.

*Nonconducting coverings for heat.*— The cork insulation *c* of the base, sides, and ceiling of a portable refrigerator is lined with cement *e* reinforced with wire-netting or expanded metal *d*.

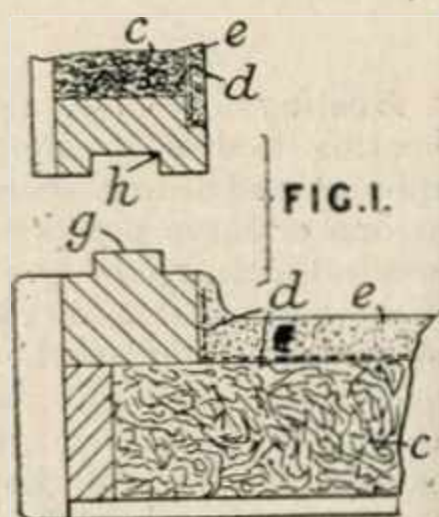

**322,188. Electrolux, Ltd.,** (Platen-Munters Refrigerating System Aktiebolag). Aug. 27, 1928.

*Thermostats.*— A thermostat for use in refrigerating apparatus comprises a heat-sensitive element containing water and connected by a conduit with a controlling member, whereby increase in pressure set up during the freezing of certain sections of water in or near the element may be utilized for the purpose of melting previously frozen sections near the controlling member. The sensitive element consists of a steel tube *a* provided with a screw filling-cap *e*, and a conduit *b* at the other end of the tube connects with a diaphragm chamber or bellows. Molten metal may be introduced into the cap prior to use in order to ensure a tight closure; and a similar sealing-means may be adopted at the junction with the conduit.

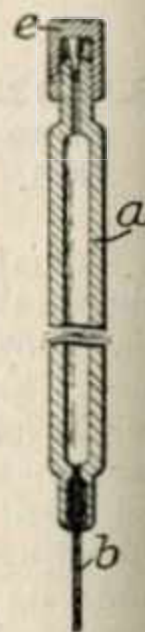

**322,204. Osborn, H. J., and Wright, A.**  
Aug. 23, 1928.

*Thermostats.*—A bi-metallic strip 1 is secured at one end to an arbor 5 which is pivoted on set screws 6, 7 and carries an oscillating arm 8. When it is desired to calibrate the thermostat, a clamping screw 9 is loosened and the free end of the arm held between set-screws 10; the element is then subjected to the desired temperature and the arm again clamped to the arbor.

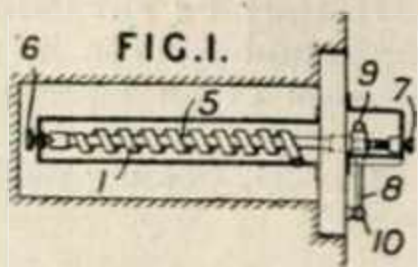

may be provided to obtain the desired ratio between furnace temperature and air temperature. The thermostatic bulb in the incoming air may be omitted, or the air may be drawn through boiling water to keep its temperature constant.

**322,305. Wingfield, B. R., and Wingfield, B. T.** Nov. 6, 1928.

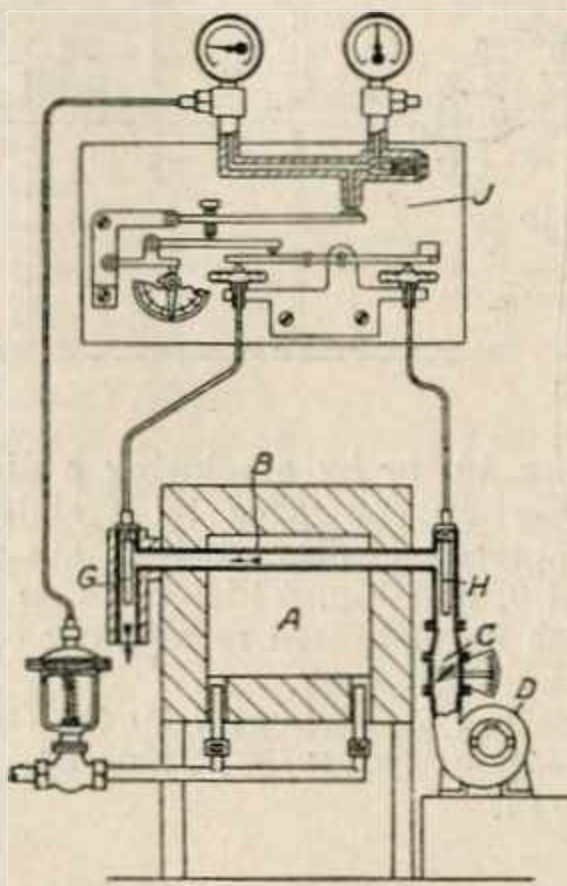

**322,440. Jerike, J.** Aug. 31, 1928.  
*No Patent granted\* (Sealing fee not paid).  
Addition to 268,812. Drawings to Specification.*

*Thermostats.*—The parent Specification describes a temperature-sensitive device consisting of two parallel metallic bars &c. connected together by two diagonally-disposed members having a coefficient of expansion different from that of the parallel members, the joints between the diagonals and the parallel members and between the two diagonals at their point of intersection being such as to transmit pressure and tension stresses without producing flexure of the bars and diagonals. According to the present invention the diagonals are connected to the parallel members by joints permitting flexure to take place and the diagonals may either not be connected together at all at their point of intersection or they may be connected in any of the ways described in the parent Specification. The invention also includes a clamp by which the diagonal members may be secured together, the clamp having two parallel arms, the free ends of which are adapted after attachment to receive a nut or a closure which can be riveted.

**322,511. McCabe, I. E.** Sept. 3, 1928.

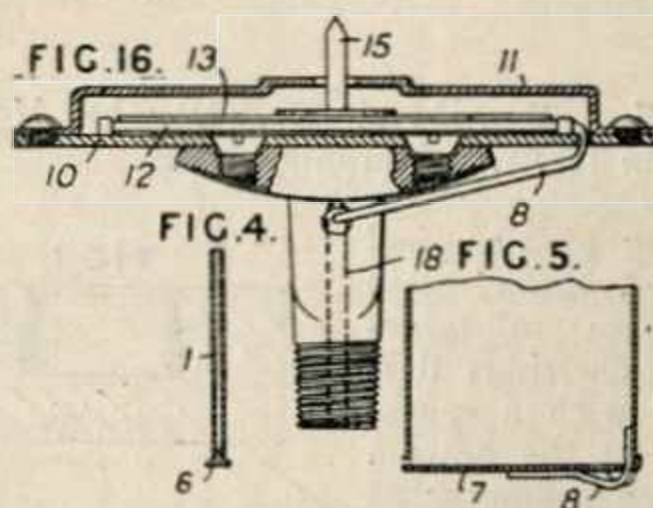

*Thermostats.*—A capsule for use in thermostatic and pressure-operated apparatus comprises a section of flattened metal tubing 1, Fig. 4, with the ends closed and sealed by means of a T-shaped strip 6; or a channel-shaped closure 7, Fig. 5, may be used. The capsule may be filled with gas or liquid through a tube 8 which is thereafter crimped and sealed adjacent the end closure, or connected to a source of pressure. A





Supporting for the capsule 12 comprises a base plate 10, Fig. 16, with a cover 11. A plate 13 resting on the capsule supports a short rod 15 which actuates any control device. The interior of the capsule communicates through a tube 8 with a conduit 18 connected to a source of pressure. The capsule is supported, on abnormal expansion, by the walls of its casing.

**322,859. Ges. für Kältechemie Ges., and Sautier, H.** Nov. 2, 1928.

*Heating by circulation of fluids.*—A non-freezing liquid for use in domestic heating radiators consists of an aqueous solution of calcium and aluminium chlorides. Specification 189,741, [Class 29, Cooling &c.], is referred to.

**323,503. Jackson, L. Mellersh-,** (Warren, Webster, & Co.) Sept. 3, 1928.

*Heating buildings.*—Steam is supplied from a boiler 10 to a horizontal main 11 having vertical branches 12 each supplying groups of radiators 14. The main steam supply is controlled by a valve 16 and an apertured disc 17, so that the quantity of steam is less than sufficient to fill all the radiators under medium temperature conditions. A similar apertured disc is arranged in a fitting 26 in a pipe supplying the branch 12, the aperture being of such size as to compensate for the drop of pressure due to the distance of each branch 12 from the main control 17. A similar apertured disc is also arranged at the inlet of each radiator, the aperture being of such size as to compensate also for the decrease in atmospheric pressure due to altitude, and the decrease in pressure of steam due to the height of the column. The discs are readily interchangeable. The valve 16 is regulated manually according to the total steam requirement due to weather conditions, and the consumption of the various parts of the system is then automatically proportioned by the apertured discs. The adjustment is arranged to be correct at about half load, and is approximate at other loads. The main adjustment may be by regulating the valve 16 to control the pressure in

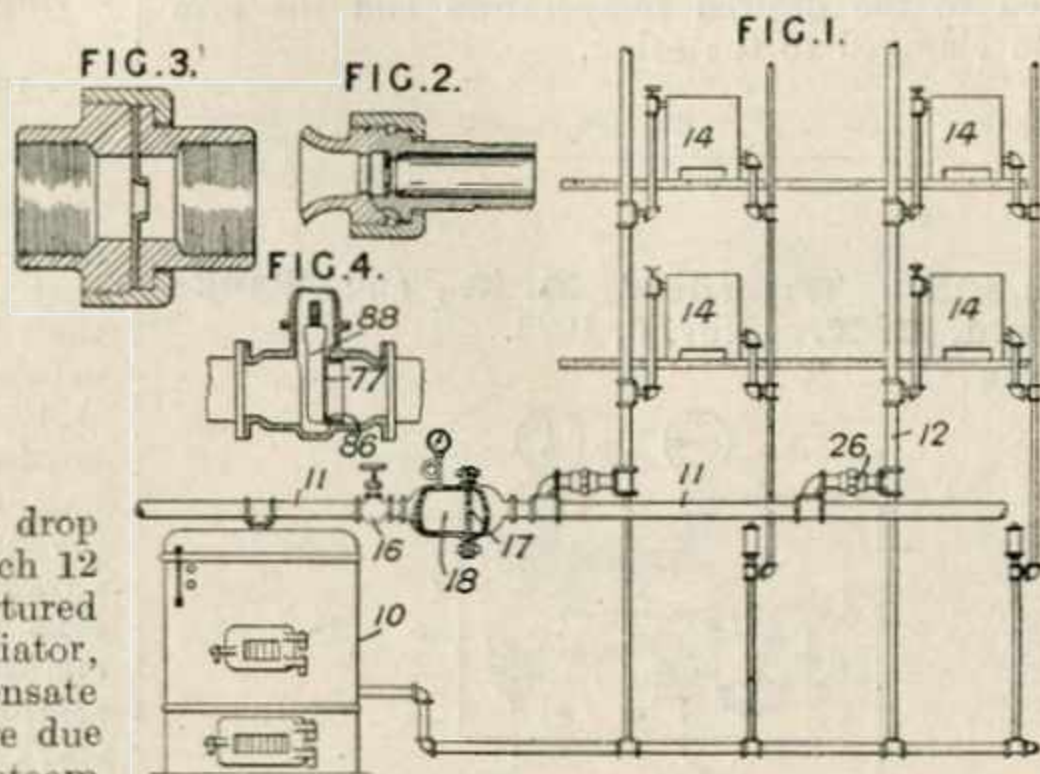

the chamber 18, or by employing a disc with a variable aperture controlled by a slider. Two forms of apertured disc fittings are shown in Figs. 2 and 3, and Fig. 4 illustrates an apertured disc 86 with an elongated rectangular opening 77 controlled by a slider 88.

Reference has been directed by the Comptroller to Specifications 13516/85, 21898/04, 15163/12, and 14181/14.

**323,687. Percival, S.,** (Henckel Mox Corporation Ges.) March 14, 1929.

*Heating by chemical action.*—A base plate 1 for an aluminothermic cartridge 3 is provided with a recess 2 which at the bottom is of such diameter as to position or centralize the cartridge, and at the top is of substantially greater diameter so that air has free access to the cover to facilitate its complete burning away on ignition of the cartridge.

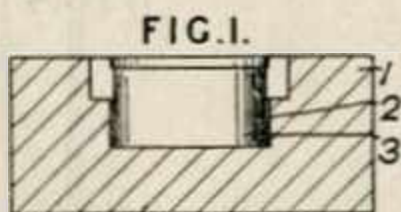

**324,317. Firestone Tyre & Rubber Co. (1922), Ltd.,** (Firestone Tire & Rubber Co.) Sept. 21, 1928.

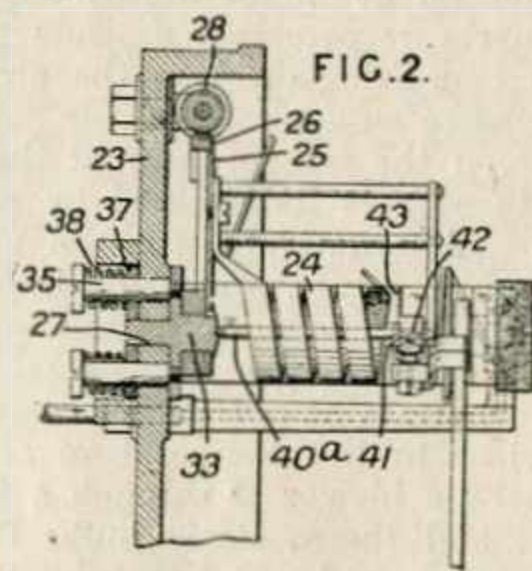

*Thermostats.*—A thermal control element for use in a timed temperature controller comprises

a coiled Bourdon tube 24 connected by flexible pipes to a thermal chamber housed in the heater. The fixed end of the Bourdon coil is secured to a plate 25 carried by a member 33 pivoted in the casing 23 at 27 and provided with studs 35 passing through arcuate slots. Springs 38 arranged between heads on the studs and a friction plate 37 hold the member 33 in its adjusted position, which adjustment is effected by a worm 28 engaging a toothed sector 26 secured to the plate 25.

**324,408. Reavell, J. A.** Oct. 27, 1928.

*Heating by circulation of fluids.*—In a heating system employing circulating heated oil, the rising expansion main *a* is curved to enter an expansion tank *b* near its upper end, and any water, steam or air entering with the oil escapes through the pipe *g*. The separated oil returns to the expansion main through a liquid seal *d* of smaller bore. The inlet *c* may be arranged tangentially. The arrangement prevents froth passing back into the main body of oil, and avoids heating of the oil in the tank *b* by convection.

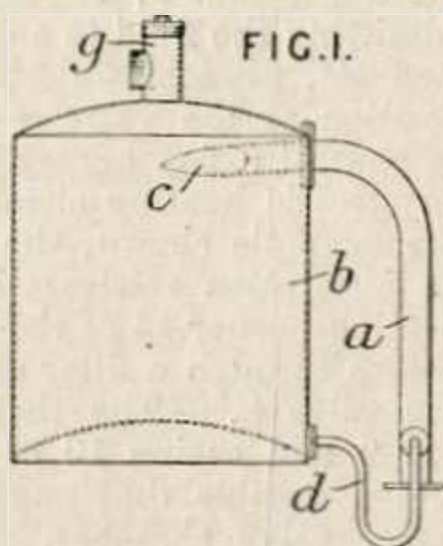

**324,712. Buchanan, J., and Buchan, C.** Aug. 3, 1929.

*Footwarmers.*—An earthenware bottle, applicable as a footwarmer, is provided with a filling aperture *a* of funnel shape, which also serves as a handle. The threaded neck *b* is substantially longer than the thickness of the wall.

Reference has been directed by the Comptroller to Specification 25301/09.

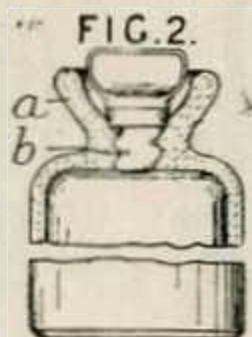

**324,929. Moufang, F.** Nov. 1, 1928.

*Thermostats.*—Relates to means for maintaining constant a pressure, liquid level, consistency of a fluid, specific gravity of a fluid, or other

characteristic, of the kind in which a jet of air impinges on a baffle the position of which is dependent on the condition to be controlled, and the resulting variations of pressure behind the jet are used to operate the relay controlling device. The invention consists in mounting the baffle so that it moves substantially at right angles to the direction of the jet. In the application to a manometer for maintaining constant the pressure of a gas, Fig. 1, the pointer 3 carries a baffle 4 which moves transversely in front of the air nozzle 5. The edge 7 normally covers half the jet opening. In the application to a liquid level-maintaining apparatus, Fig. 2, the arm 12 of a float 10 carries a baffle 13 which moves in front of the air nozzle 14, which is adjustable on the support 17. This arrangement may be used to maintain the consistency of a liquid such as paper pulp flowing through the tank 8. In the application to the regulation of the specific gravity of a liquid, Fig. 3, the liquid is supplied continuously through a pipe 20 to a

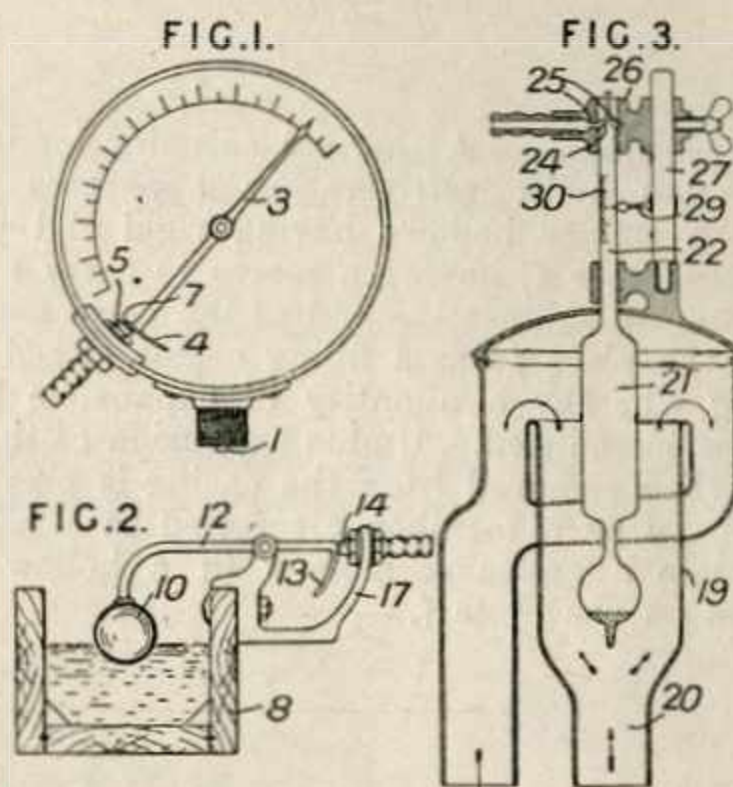

vessel 19, and the stem 22 of a float 21 moves so that its upper end 24 obstructs more or less the air nozzle 25, which is formed as an annular opening in the part 26, which can be vertically adjusted on a support 27. The latter carries also a stationary pointer 29 which indicates on a scale 30 the specific gravity of the liquid at any time. The apparatus may also be employed for maintaining constant voltage or current strength, quantity of material fed, temperature, output, speed, direction and travel of a vehicle, vessel or airship, or other characteristic. Any kind of relay device may be employed, e.g., that described in Specifications 273,016, [Class 100 (i), Feeding and delivering webs &c.], and 273,602, [Class 97 (iii), Thermometers &c.]. Specifications 183,840; 293,790, [Class 69 (ii), Hydraulic presses &c.], and 318,486, [Class 57, Governors &c.], also are referred to.



ULTIMHEAT®  
VIRTUAL MUSEUM

324,957. **Lightfoot Refrigeration Co., Ltd., and Nolcken, Woldemar George, Baron.** Nov. 7, 1928.

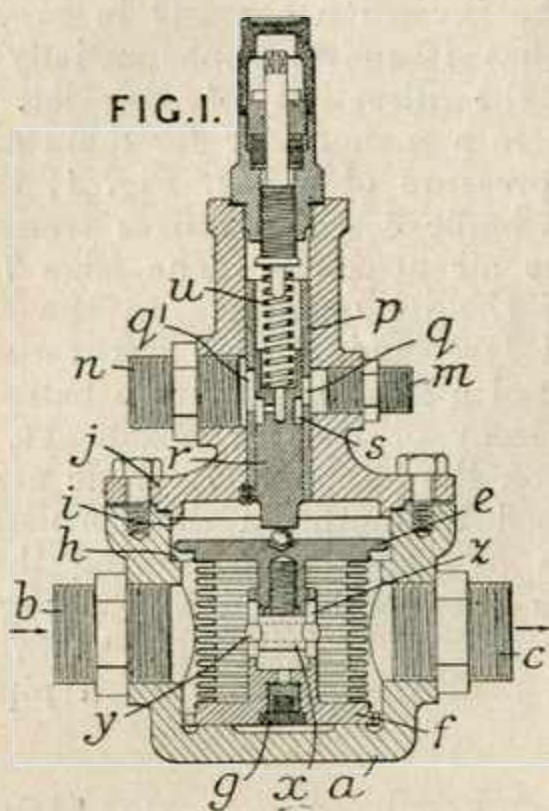

**Thermostats.** — A thermal actuator for use in connection with refrigerating apparatus comprises a copper bellows having rigid end plates *e, f*, the plate *e*, having a recess to carry a steel ball bearing against the end of the valve member while the plate *f* has a filling orifice closed by a plug *g* whereby a quantity of expansible liquid may be introduced. Undue expansion of the bellows when removed from the casing is prevented by pins *y* on a member *x* screwed to a boss on the plate *e* engaging slots *z* in a hollow boss formed on the plate *f*.

324,961. **Foster, C. E.** Oct. 3, 1928.

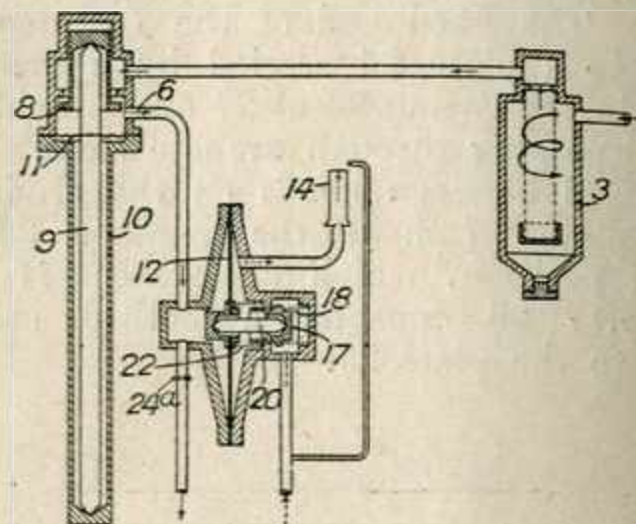

**Heating buildings &c.** — A cooling or heating system is controlled thermostatically through the agency of a pressure fluid, such as cooling-water, the thermostat 9, 10 serving to control a valve 8 admitting the fluid to a conduit 6 having a restriction 24<sup>a</sup>, whereby fluid pressure dependent on the position of the valve 8 acts on a diaphragm 12 to control a gas burner valve 17, or a switch of an electric heating element or other member. In the example shown, the flow of cooling-water of an absorption refrigerating machine controls the heating burner 14 of the generator, and the water passes through a filter chamber 3 before reaching the valve 8. The thermostat may comprise a rod 9 and casing 10 of different expansibilities, and a flexible diaphragm 11 is provided in the water valve chamber. A rod 20 bears on the centre of the diaphragm 12 and on the burner valve 17, and the diaphragm is engaged by a spring 22 and the valve by a spring 18. There may be multiplying mechanism on the thermostat, and gas, air, or other fluid may be used as the pressure medium.

325,015. **Marshall, R.** April 30, 1929.

**Steam traps.** — To prevent pitting and scoring of automatic discharge valves for steam traps, the co-acting valve surfaces are surrounded by a finely perforated cylinder, and a masking device, associated with one of the valve surfaces, slidably fits the cylinder, delaying passage of the fluid until the surfaces have been separated to a certain extent, also preventing direct impingement of the fluid upon one or both surfaces. Float-controlled discharge valves for steam traps are shown in Figs. 4 and 6, the floats 31, which rise and fall in the casings 30, surrounding stationary discharge pipes 32 and being formed with finely perforated inner walls 41 to impede passage of solid particles. In the form shown in Fig. 6, the valve member 54, closing the outlet 34, remains seated until, as the float descends, a

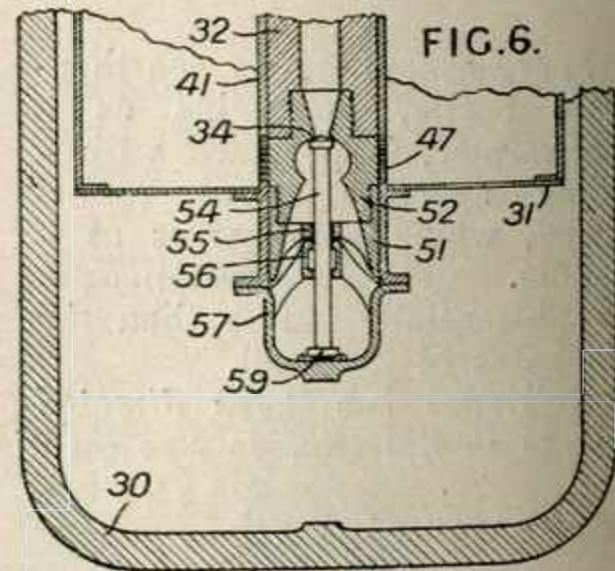
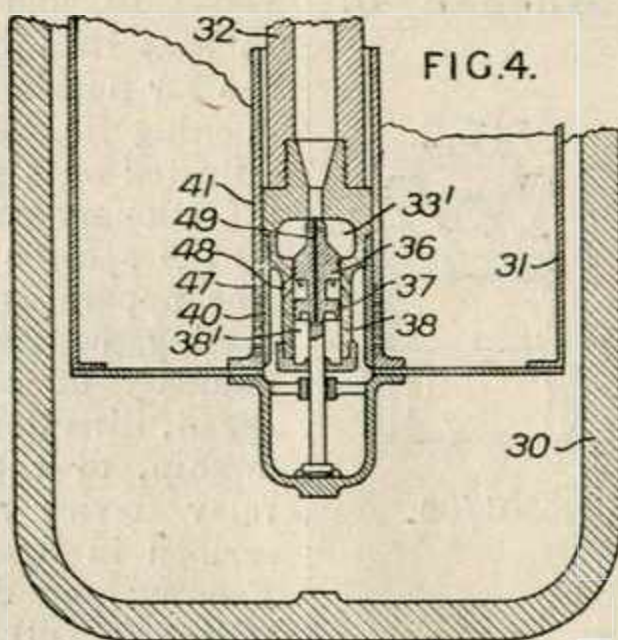

cross bar 56 in the foot 57 of the float, engages the flanged end 59 of the valve stem. Until the valve has been thus opened, a skirt or flange 51 depending from the outlet member 52 masks the perforations 47, preventing passage of fluid. A cross bar 55 in the outlet member guides the stem. In the modification shown in Fig. 4,

piston members 36, 37 on the valve stem slide in a closed cylinder 38, delaying passage of the fluid until ports 48 are uncovered. This device supplements the action of the skirt 40 masking the perforations 47. A bore 49 in the valve stem allows passage of fluid to equalize pressures in the chambers 33<sup>1</sup>, 38<sup>1</sup>.

**325,179. Pollak, J. E.,** (Vageler, P. W. E.).  
May 24, 1929.

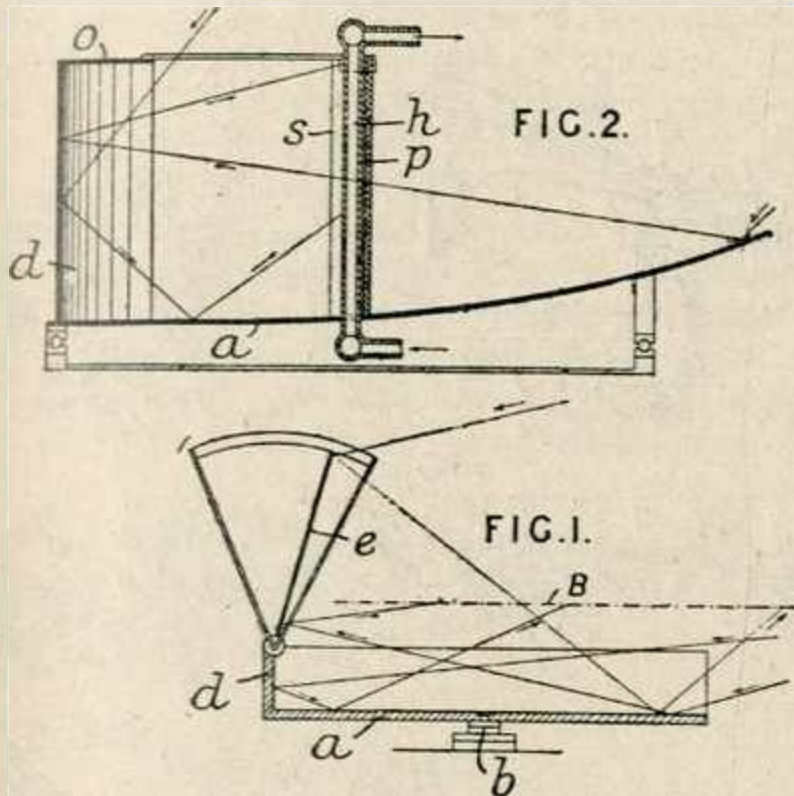

*Solar heat, utilizing.*—Apparatus for collecting sun rays comprises two mirrors, one, a parabolic long mirror *a* rotatably mounted on a journal *b* so as to follow the course of the sun in a horizontal plane, being driven by clockwork, and the other, a vertical reflecting wall *d* rotating with the mirror *a*. The sun rays falling on both mirrors is reflected to and concentrated in the focal line *B*. An additional mirror *e* pivoted to the upper end of the reflector *d* and operated to move about its lower edge by clockwork also cooperates to concentrate the incident rays on to the first mirror and thence to the focal line *B*. In a modified form, Fig. 2, for less tropical latitudes the focal line is vertical and the reflectors *a*, *d* are similarly rotated, a stationary heating body *h* being arranged in the focal line. The heating body *h* may be surrounded with an insulating sleeve *p* having a longitudinal slot. Supplementary mirrors *o*, *s* may also be fitted.

**325,560. Barker, A. H.** Oct. 22, 1928.

*Radiators for heating buildings.*—A heat-radiating metal plate is fixed to a wall surface and heated by gases passing through tubes surrounded by water or other medium circulated to equalize the temperature, the heating gases being exhausted by a fan to the open air. Hot gases from a flame *F* are drawn through a hood *B*<sup>1</sup> by a fan *H* to an exterior pipe

*g* through tubes *B* heating water in passages with vertical connecting passages integral with the plate. A single straight tube *B* may be used, or a serpentine inserted in a reservoir connected with the water system. Side pieces *J*, one carry-

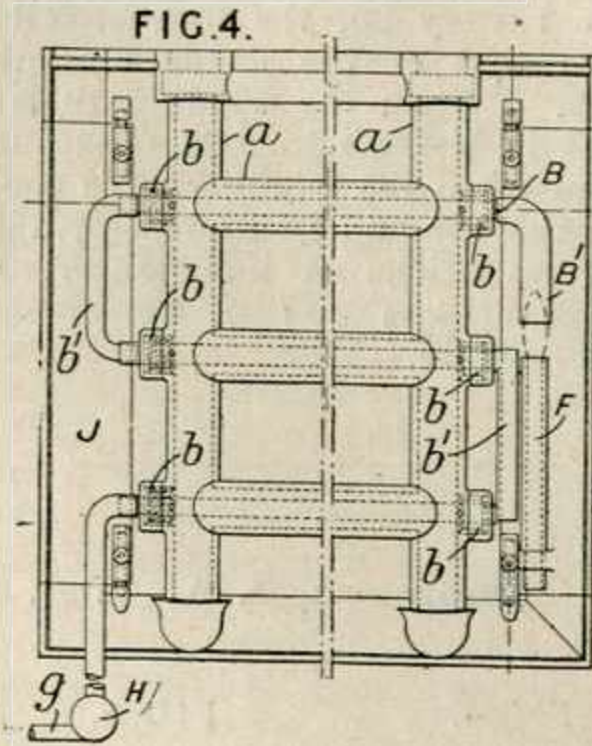

ing a gas jet, may be hinged to the metal plate to give access to the tubes *B*, *b*<sup>1</sup> and fluid-tight glands *b*. A pilot light and thermostat may be provided. Specification 266,836 is referred to.

**325,874. Dicker, S. G. S.,** (Naamlooze Vennootschap Philips' Gloeilampenfabrieken).  
Nov. 22, 1928.

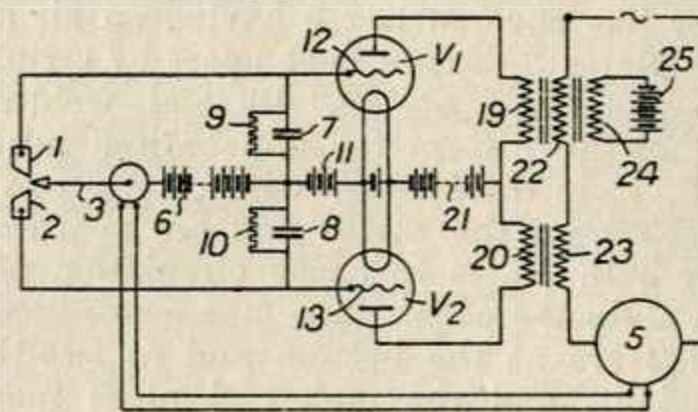

*Thermostats.*—In a thermionic valve circuit suitable for controlling temperature, voltage, speed, &c., a pointer *3* of a measuring instrument indicating the quantity to be controlled moves between stationary contacts *1*, *2*. The pointer is connected to a high voltage source *6*, and condensers *7*, *8* are connected between the stationary contacts *1*, *2* and the opposite terminal of the source *6*, the separation of the contacts *1*, *2* being such that when the pointer *3* is in mid position a disruptive discharge is just avoided. Leakage resistances *9*, *10* are connected across the condensers. The condensers *7*, *8* are also connected to a grid biasing battery *11* which applies the necessary bias to the grids *12*, *13* of two triodes *V*<sub>1</sub>, *V*<sub>2</sub>, the anodes of which are connected by the primaries *19*, *20* of two transformers to the anode battery *21*. When the pointer *3* is in mid position, the anode current through the primaries *19*, *20* is negligible, but if



ULTIMHEAT®  
VIRTUAL MUSEUM

a discharge takes place between the pointer and one of the contacts 1, 2, one of the grids becomes positive, and direct current flows in one of the primaries 19, 20. An alternating current supply passes through the windings 22, 23, e.g., to an electric furnace 5, and a third winding 24 is supplied by a battery 25, the magnetization being contrary to that of the anode current in the winding 19. When the winding 19 is excited, the current in the winding 22 consequently increases, and when the winding 20 is excited, the current in the winding 23 decreases, due to corresponding variations in inductance. Specification 221,583, [Class 40 (iii), Telegraphs, Electric] is referred to.

325,928. Thomson, J. A. Dec. 31, 1928.

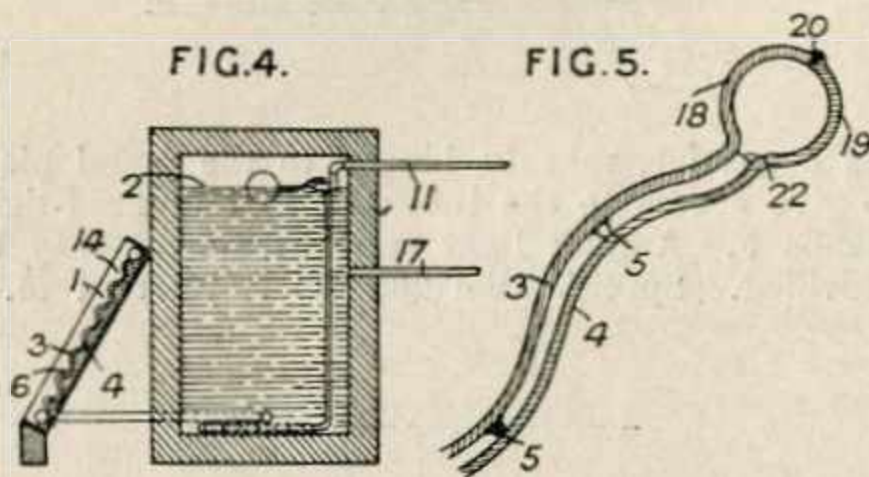

*Solar heat, utilizing.*—A storage tank 2 is connected to a heating element 1 exposed to the sun, in a vertical or inclined position. The heating element consists of two corrugated plates 3, 4 in a glass or like covered box 6 having an air space 14. The plates 3, 4, are kept apart by strips 22, and are deformed at 18, 19 and welded or soldered at 20 to form top and bottom headers. Baffles 5, formed of rods, wires, or strips are inserted between the plates and are spot-welded to one or both plates to cause circulation of the liquid in a zig-zag path. The pipe connections to the tank 2 are at the bottom and at two-thirds of the height, and the tank and pipes may be heat-insulated. Supply and discharge pipes 11 and 17 are provided.

326,309. Electroflo Meters Co., Ltd., (Republic Flow Meters Co.). Feb. 13, 1929.

*Thermostats.*—In a device for controlling temperature, a temperature-responsive member determines the action of a clutch which couples a driving to a driven shaft. The driven shaft controls the heating through a switch or valve. The temperature responsive device comprises a thermocouple operating a moving coil 3 carrying a pointer 2 moving over a scale 1. The pointer can be held in any position by means of a bar 12 carried by a rod 11 pivoted at 10. The rod 11 carries a pin 13 overlying another pivoted rod 8,

the upward movement of which lifts the rod 11. The rod 8 has a terminal portion 15, 16, Fig. 9, engaging the pointer only within small limits, and has a backward extension 17 in the path of one arm 18 of a bell crank 19 pivoted at 20. The other arm 21 of the bell crank engages a cam 23 rotated by an electric motor 25. A shaft 27 in line with the shaft 24 is adapted to be intermittently connected with it through a clutch device 28. This consists of a plate 29 secured to the shaft 24 and having a hook 30 pivoted to it at 31. A tripping lever 33 is pivoted to the plate at 34 and to a link 36 at 35, the link 36 being pivoted to the hook 30 at 37. The hook 30 engages an arm 38 to drive the shaft 27. A selector 40

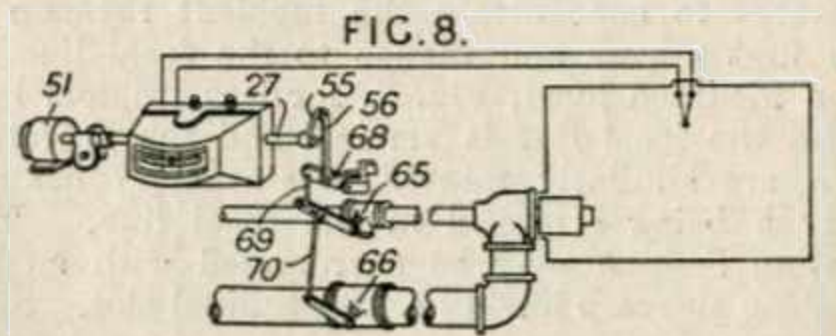
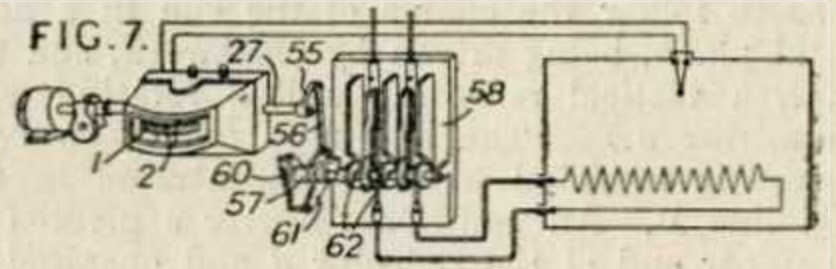
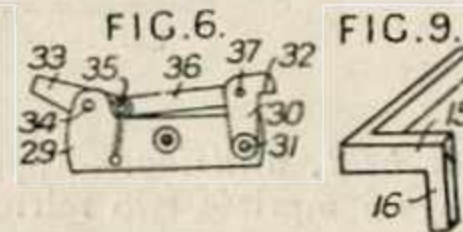
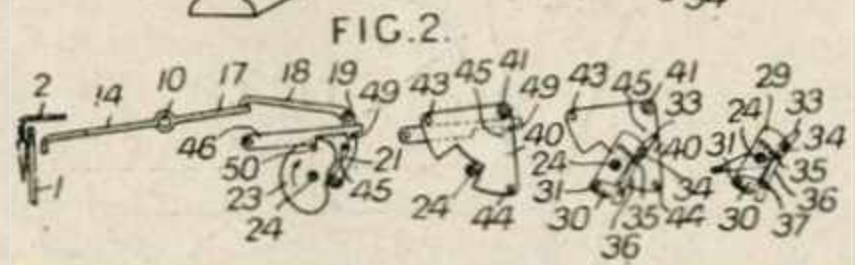
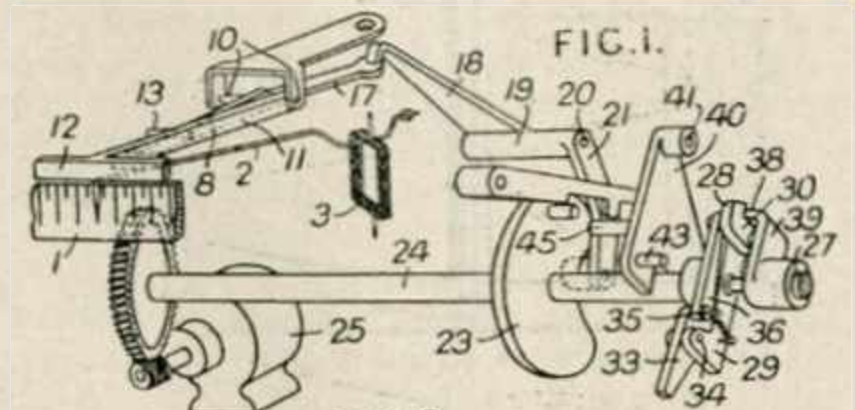

pivoted at 41 is biased towards the shaft 24, and has pins 43, 44 adapted to engage the lever 33 to move the hook 30 out of engagement with the arm 38. A pin 45 on the plate 40 engages with the arm 21 of the bell crank 19, and a latch member 46 is adapted to engage a trip pin 50 on the cam 23 and the pin 45 on the plate 40. In operation, continuous rotation of the cam 23 actuates the bell crank 19 intermittently thus causing intermittent depression of the rod 8 into the path of the pointer 2. Assuming that the furnace is to be heated up from the cold, the depressor 8 is set so that except at and above the

predetermined temperature it is not intercepted by the index 2. When the cam 23 is rotated and the bell crank 18 and depressor 8 actuated, the latter passes the index 2 as shown in Fig. 2. The pin 50 raises the latch 46 so that the detent 49 on the latch does not engage the pin 45 on the plate 40. Further rotation of the cam permits the arm 21 to engage the pin 45 and raise the plate 40 to the position shown in Fig. 2, where it is retained by the detent 49 when the latch 46 is allowed to fall. As long as the depressor 8 continues to pass the index 2, the plate 40 is held in the upper position either by the pin 45 or by the arm 21. Further rotation of the cam causes the hook 30 to engage the crank arm 38, and the shaft 27 is driven so that heating medium is delivered to the furnace. One half a revolution is sufficient for this purpose, and the driving and driven shafts are then disconnected by the outstanding part of lever 33 engaging with pin 44 and breaking the toggle, thus disengaging the hook 30 from the crank arm 38. In succeeding cycles, the plate 40 remains in its upper position, the pin 44 remains in the path of the lever 33, and the toggle is broken when otherwise the arm 38 would be engaged by

the hook 30. When the temperature is sufficiently raised, the index 2 interrupts the movement of the depressor, and the arm 21 allows the plate 40 to fall when the cam 23 raises the latch 46. The pin 43 is then in the path of the lever 33, and the pin 44 is out of its path, so that the hook 30 engages the crank arm 38 and the shaft 27 is rotated to diminish the heating until the lever 33 contacts the pin 43 and the clutch is released. There is no further engagement between the hook 30 and crank arm 38 until the temperature falls sufficiently to move the index 2 out of the path of the depressor 8. If thermal lag causes the furnace temperature to rise after the heating is reduced or cut off, the index 2 is prevented from moving out of the path of the depressor by the part 15. In the application to an electric switch, Fig. 7, the driven shaft 27 operates through an arm 55 and link 56, a bellcrank lever 57 which is connected by a spring 60 to an arm 61 operating the contacts 62 of a snap switch 58. In the application to a gas or oil heated furnace, Fig. 8, the driven shaft 27 operates valves 65, 66, through link-work 55, 56, 68, 69, 70. Specification 318,308 is referred to.

**326,752. Smith & Sons (Motor Accessories), Ltd., S., and Eckford, F. G.** Sept. 7, 1929.

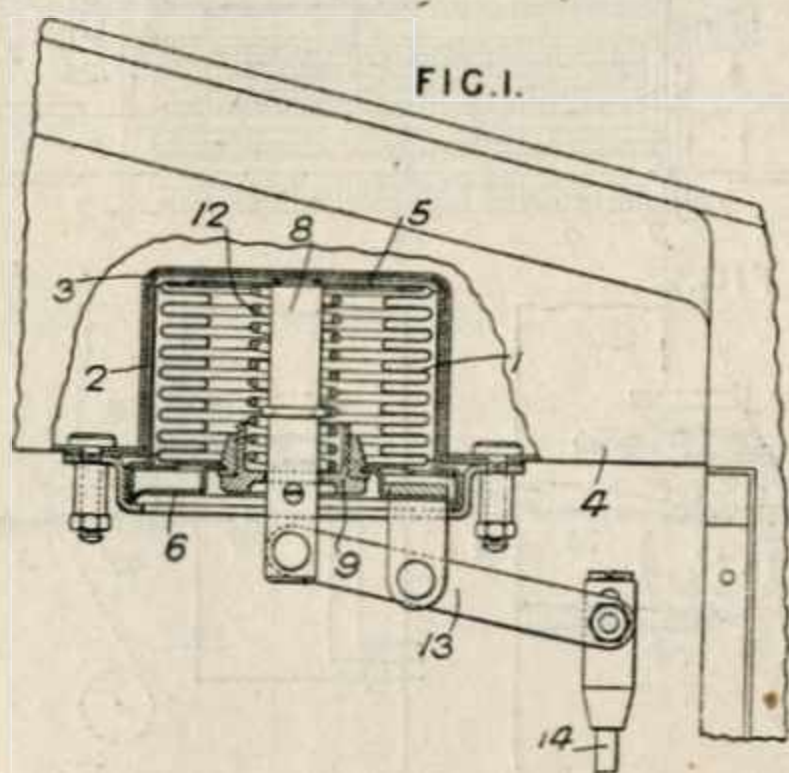

*Thermostats.* — A thermostatic device of the bellows type for controlling the air-admission shutters of motor-car and like radiators comprises a bellows member 1 surrounded by vapour or liquid medium in a casing 2 housed in a recess 3 in the radiator header 4, and a spring 12 within the bellows surrounding a thrust rod 8 connected by a lever 13 to the shutter rod 14. The spring bears at one end against the free end 5 of the bellows and at the other end is seated in a recessed member 9 screwed in the cover 6 of the thermostat chamber, whereby the resistance to movement of the bellows due to rise of temperature may be adjusted.

**327,186. Kilburn, B. E. D., (Burgess Laboratories, Inc., C. F.).** Dec. 31, 1928.

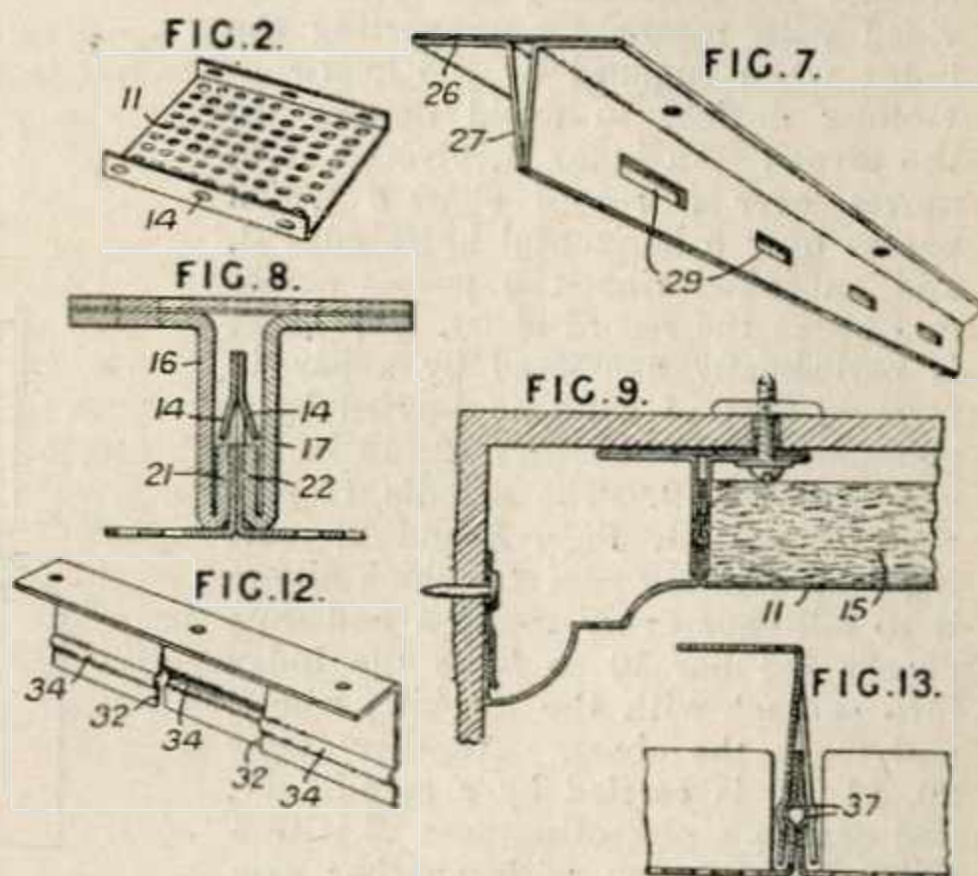

*Nonconducting coverings for sound.* — Sound-absorbing wall and ceiling coverings, applicable also to the outside of structures, consist of felted wood fibre, steel wool, hairfelt, wool, or porous ceramic products 15, Fig. 9, faced with perforated sheets 11, preferably metallic, the number and size of the perforations varying according to the pitch of the sounds to be absorbed, and the unperforated area affording a substantially continuous surface which may be painted. The holes may be, for example, about one-eighth of an inch in diameter and vary from one to sixteen per sq. in., thus occupying from 0.4 to 35 per cent of the area. A sheet of soft filter paper may be placed inside and against the perforated sheet. The sheet material may be secured by

nails or screws, but is preferably in the form of flanged tiles 11, Fig. 2, secured to sheet-metal furring strips 26, Fig. 7, or 16, Fig. 8. The flanges of the tiles are inserted between the spring legs 27, 17, and are held by lugs or ears 14 engaging in slots 29 or upon the upturned edges 21, 22 of the legs. A modified furring strip, shown in Figs. 12 and 13, consists of an angled strip with slits 32 and beads 34 to snap over ribs 37 on the tiles. The perforated sheet may consist of vulcanized fibre, phenol-condensation products, or veneered wood, instead of sheet metal.

**327,326. Nielsen, H. F.** May 25, 1929.

*Nonconducting coverings.* — The lagging 2 of a pipe 1 is provided with a cup-like socket 3 having an extension 4 with a screw 5 to secure it to the pipe. When applied to existing piping, the socket is divided diametrically at 6, and the two parts may be dovetailed to fit into one another. Displacement of the parts is prevented by the provision of bevelled meeting edges 7.

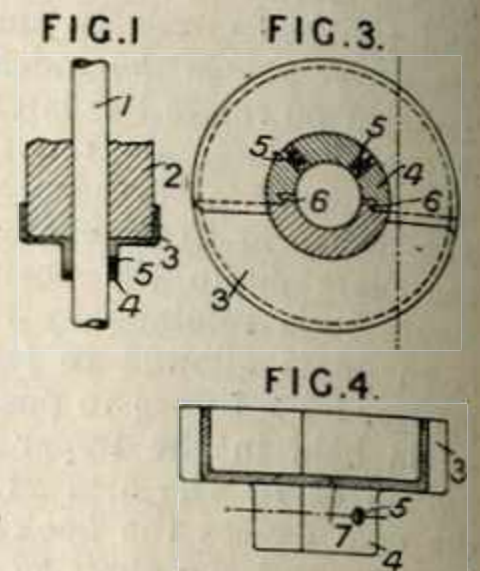

**327,861. Bridges, J., and Electroflo Meters Co., Ltd.** April 12, 1929.

*Thermostats.*—Apparatus for recording and controlling temperature of the type in which a temperature-responsive index is periodically depressed to record the temperature or actuate the controlling device, is provided with means for supporting the index when engaged by the heat-controlling device, to avoid damage to the pivots. An index 4, pivoted at 5, moves over a record chart 6 which passes over a horizontal knife edge 3, and an inked ribbon 9 passes across and above the record chart. The index is periodically depressed by a bar 10 forming part of a frame carried by a spindle 11 with bearings 12, 13 in the side plates 1, 2. The spindle 11 carries a lever 14, Figs. 1 and 2, resting on a rotating cam 15 which allows it to fall once every rotation and thus causes the bar 10 to force the index into contact with the marking ribbon and mark the chart. Another frame 20, 21, 22 is carried by a spindle 17, and carries a projecting part 23 with a roller 24 engaging with another cam 25 so shaped that the frame 20 is allowed to fall slowly once each rotation just after the fall of the bar 10. A threaded rod 26 mounted in the side plates 1, 2 carries a nut 29 having forked arms 30, 31 adapted to engage a carriage 33 capable of axial movement along a spindle 34 of D or square cross section. The nut 29 is adjustable by rotating the knob 32. The carriage, Fig. 4, comprises a sliding block 37 and a tongue 39 extending upwards to form an index moving over a temperature scale 40, and downwards into proximity with the index 4. A stop 41 prevents the index from passing beyond it in response to an increase of temperature beyond that indicated by the tongue 39. A flat supporting bar 42 is arranged level with and behind the knife edge 3 in such position that, when the rod 22 falls just

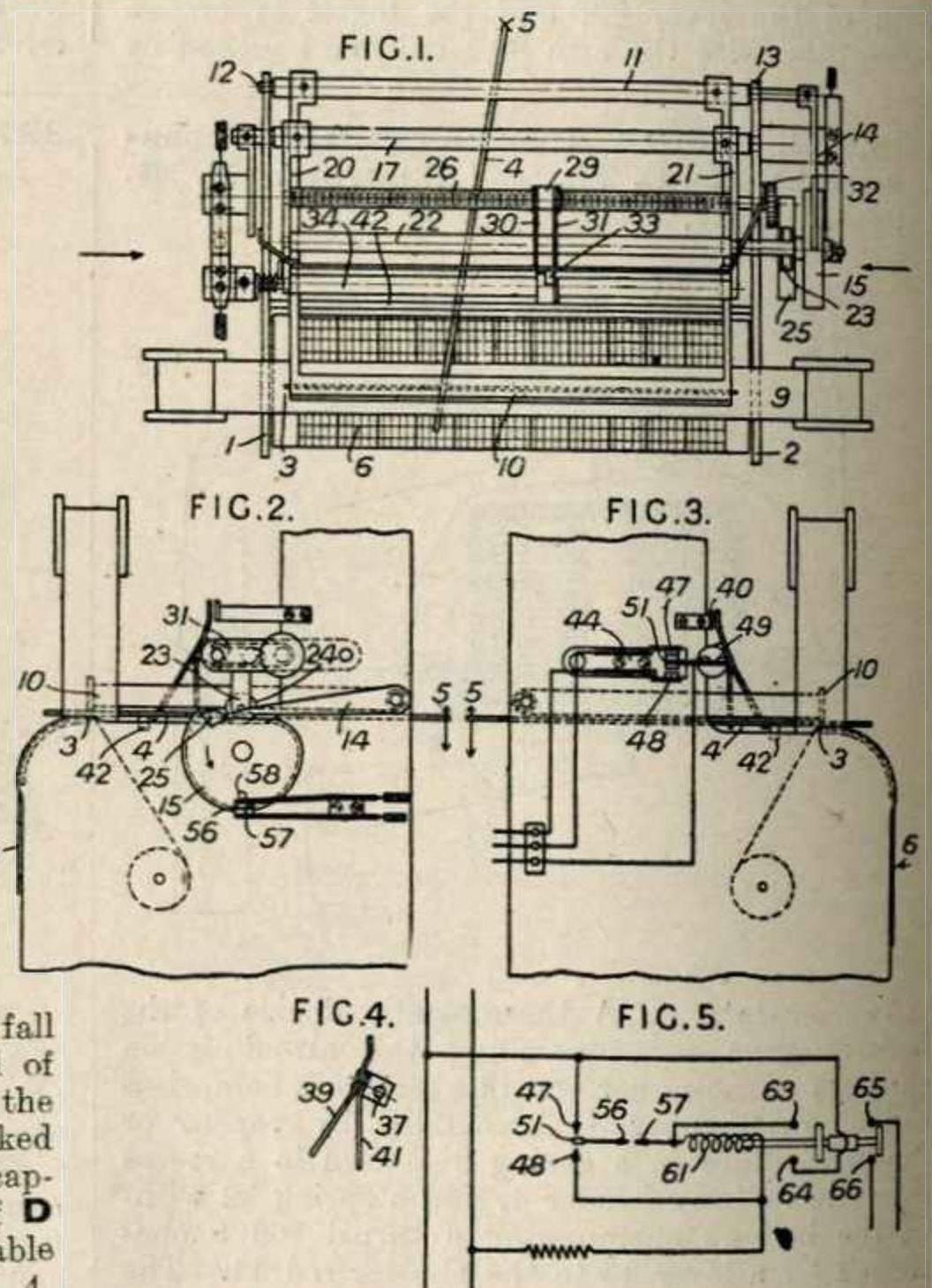

after the bar 10 has fallen, the resulting movement of the spindle 34 and carriage 33 causes the tongue 39 to pass just behind the bar 42 unless the index 4 intercepts it, when it is caused to slide to a position over the supporting bar 42. The spindle 17 carries an insulating block 44 with two contacts 47, 48, and the spindle 34 carries an insulating block 49 with one contact 51 nor-



mally engaging the upper contact 47, but adapted to be deflected into engagement with the contact 48 when the index 4 intercepts the tongue 39. A pair of normally open contacts 56, 57 are arranged near the cam 15, and the pin 58 on the cam closes these contacts shortly after the spindle 34 and carriage 33 are allowed to fall. The contacts open shortly before the spindle 34 is lifted. Fig. 5 shows the electrical circuit. Assuming that the temperature is too low, the index 4 does not intercept the tongue 39, and the contacts 47, 51 remain closed. The contacts 56, 57 are then closed, and the solenoid 61 is energized so that contacts 63, 64 are closed, and also

contacts 65, 66 which control the supply of heating medium. This provides a path for the current through the solenoid 61 after the contacts 56, 57 are separated, and the contacts 65, 66 therefore remain closed until as a result of increasing temperature the index 4 intercepts the tongue 39 and the spindle 34 is rocked to open contacts 47, 51, and close contacts 48, 51. The solenoid 61 is thereby short-circuited and the contacts 63, 64 and 65, 66 are opened to decrease the supply of heating medium. The solenoid is not energized again as long as the contacts 48, 51 are closed by the index 4 intercepting the tongue 39 during the cycle of operations.

**327,875. Still & Sons, Ltd., W. M., and Adamson, A. G.** April 29, 1929.

*Radiators.* — In a steam-heated radiator which employs the difference between the expansion of the radiator body and a wooden rod to control the inlet valve, the wooden rod *g* is contained within a metal tube *h* from which it is spaced apart by rings *i*. The tube is closed at one end by a fixed plug *k* having a pin *k*<sup>1</sup> which controls the position of the valve *d*. The other end of the tube fits over a supporting plug *l* which can be adjusted by means of a threaded member *l*<sup>1</sup>. A ring of packing *m* and heat-insulating discs *n* are provided. The wooden rod

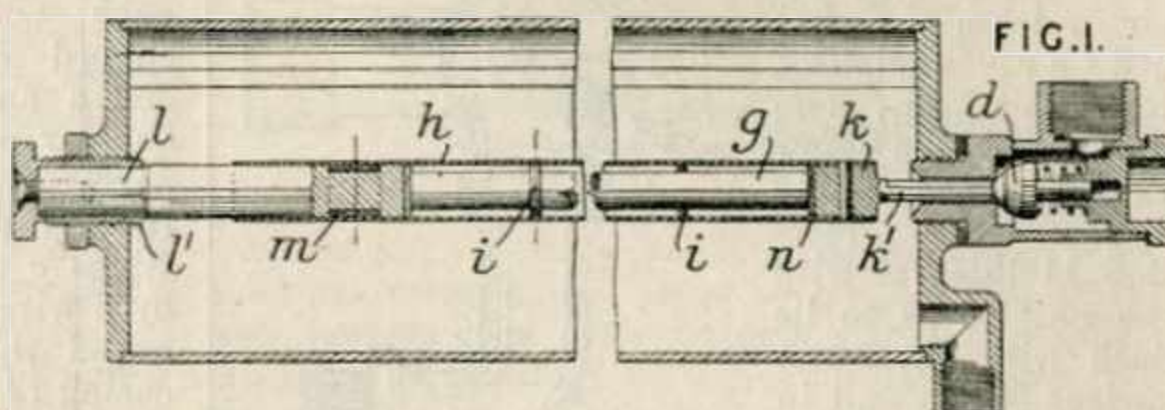

is prevented from being damaged by the steam, or charred by contact with the supporting metal ends.

**327,886. Altheimer, B.** May 6, 1929.

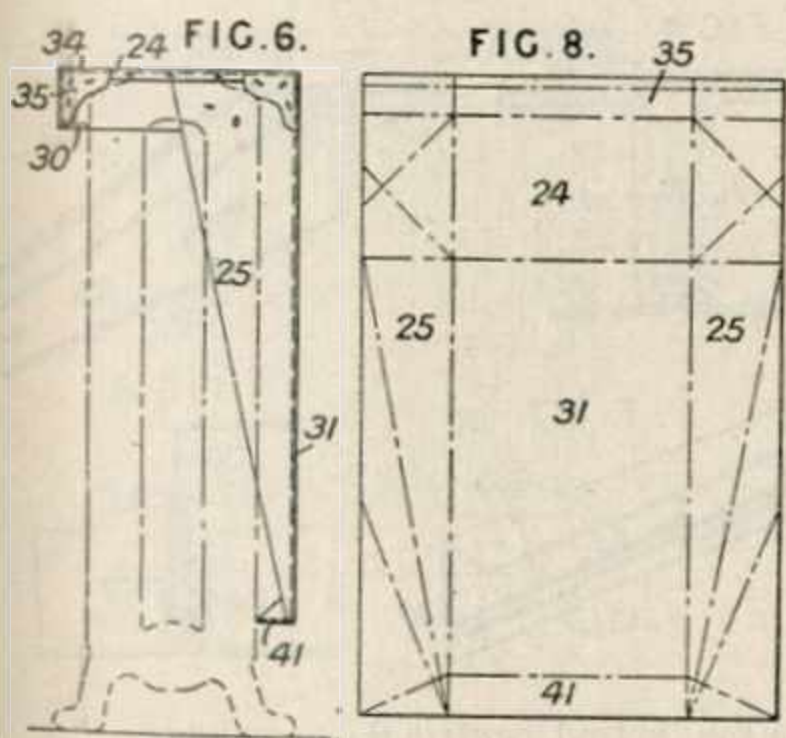

*Radiators.* — A radiator cover comprises a rectangular sheet of flexible material, e.g. paper or textile fabric with several creases for folding it into an L-shaped cover and provided with means such as staples or stitches for holding it in its folded position. The sheet is bent on the lines shown in Fig. 8 to form a cover as in Fig. 6 for the top 24, sides 25, and back 31 of the radiator. A dust ledge 41 is formed at the bottom of the back and is turned to the radiator or to the wall.

An inwardly turned dust ledge 30 may be formed on a downwardly turned front edge 35. The edges may be reinforced with a wire frame and the corners by a metal bracket 34. The top may be stiffened by a cardboard or metal plate and by angle strips at the edges. The sides of the shield may converge towards the bottom to grip the radiator.

**327,978. Gas Light & Coke Co., Clark, J. G., and Masterman, C. A.** Jan. 14, 1929.

*Thermostats.* — A thermostat comprises a capsule with a diaphragm displaced by the change of state of a material solid at normal temperatures, such as paraffin wax, beeswax or type metal. The capsule 1 is conical and closed at its smaller end by a plug 3 and at its wider end by the diaphragm 5 which actuates

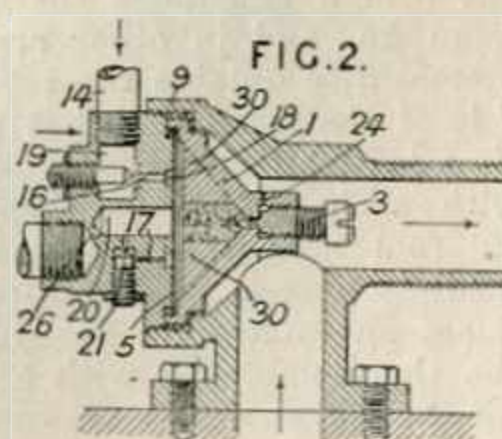



ULTIMHEAT  
VIRTUAL MUSEUM

member connected therewith, e.g. a valve with passages 14, 19, 16, an annular pass 18 and plug 20, 26 or a bye-pass 17, 21. A hot water radiator or other casing has shoulders 9 in which lugs on the capsule engage. A little water fills additional space in the capsule and is introduced at 3, 24, the latter then being soldered. The capsule carries internal ribs 30 and has at the smaller end an internal ring forming a seating for the plug 3.

**328,051. Case, W. G.** Jan. 26, 1929.

*Radiators.* — A screw-down valve, more particularly for air release in hot water radiators, towel rails, &c., comprises a simple screw 12 with coned end 13 disposed in a projection 11 integral with the unit so as to lie flush with the outer surface of the unit in the closed position of the valve. The relief passage 17 extends from above the valve seating 14 to the atmosphere through the wall of the unit itself, as shown. Specification 319,493 is referred to.

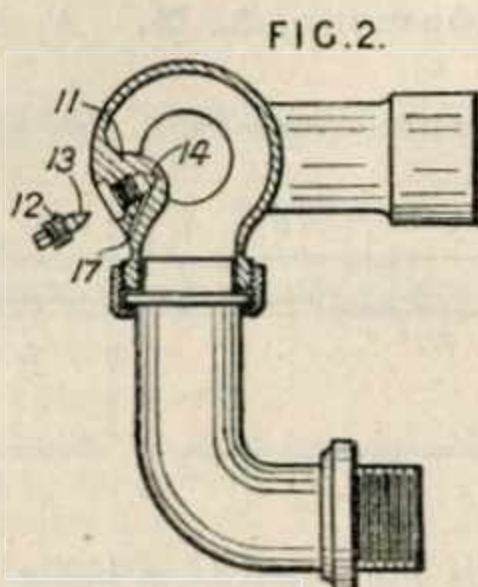

outside temperature. The thermometer *a* within the room may also be provided with means for reducing time lag.

**328,472. McCulloch, W. B.** May 17, 1929.

*Nonconducting coverings for heat.*

— A heat nonconducting covering for domestic hot water cylinders or cisterns is formed of several sections each with a V-shaped or pointed end *a* and a rectangular part *b*, the parts *a* covering the top, and the parts *b* the sides of the cistern. Rings *c* on the apices of the sections are joined by a wire or cord *d* and bands *e* bind the parts *b* round the cistern. Each section comprises a casing of asbestos paper, fabric or other material containing a substance such as asbestos, magnesia, or slag wool.

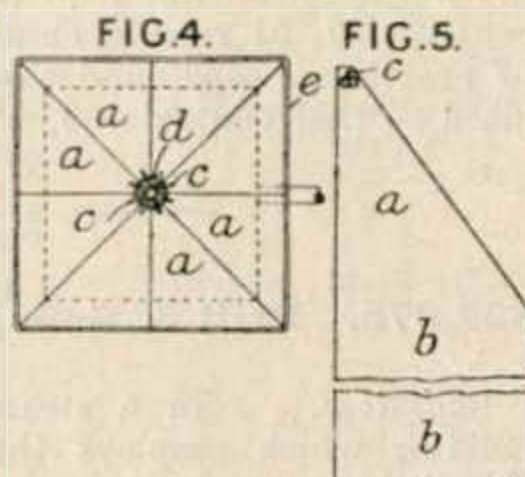

**328,456. Foster, C. E.** Aug. 2, 1929.

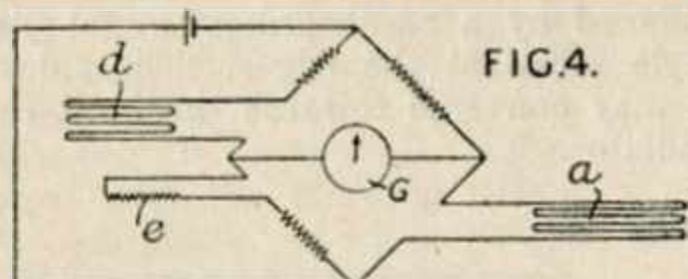

*Thermostats.* — Apparatus for use in controlling, or facilitating the control of, the temperature of a silo &c. or in a room &c. comprises a Wheatstone bridge arrangement containing in one arm a resistance thermometer *a* within the room &c. and in other arms resistance thermometers *d*, *e* outside the room. The thermometer *d* is of elongated form having means for reducing time lag while the thermometer *e* is not provided with such means, so that a sudden change of external temperature unaccompanied by an immediate change in the internal temperature produces an immediate change in the resistance of the thermometer *d* with a consequent deflection for the galvanometer *G*, enabling the temperature within the room &c. to be adjusted in anticipation of the change which would subsequently take place therein in consequence of the change in the

**328,617. Kilburn, B. E. D.,** (*Burgess Laboratories, Inc., C. F.*) Dec. 31, 1928. Divided on 327,186.

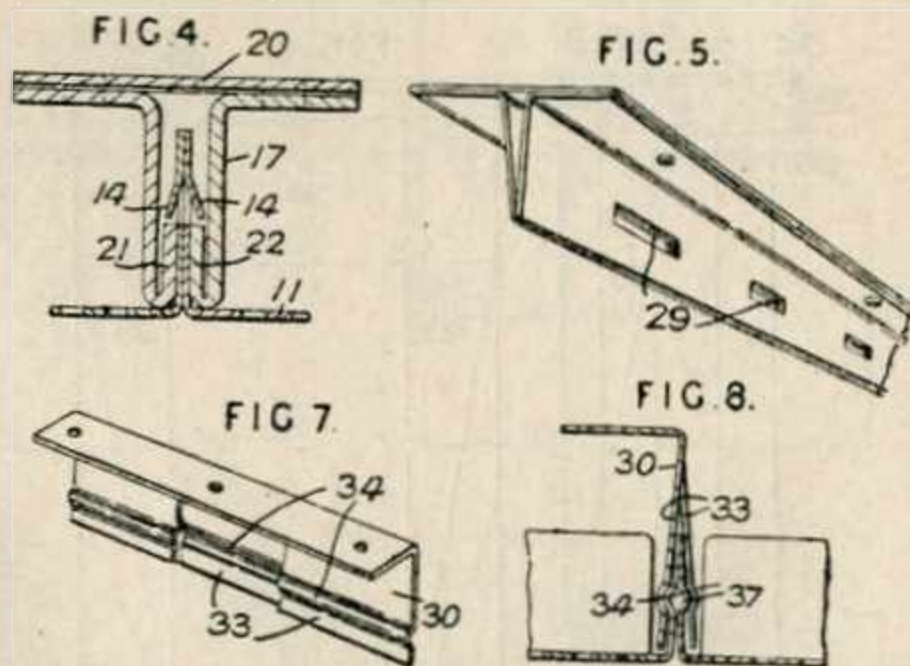

*Nonconducting coverings for sound.* — A support or facing for sound-deadening coverings on walls and ceilings consists of perforated and flanged plates or tiles 11 of metal or other material, and metallic furring strips having resilient members provided with ledges, slots, or beadings to engage with projections on the plates. The furring strip, Fig. 4, is T-shaped and consists of resilient members 17 welded or otherwise secured to a back plate 20, or integral therewith, the lower edges 21, 22 being folded to form ledges for lugs 14 on the plates 11. In Fig. 5, the

resilient members have slots 29 to receive the lugs 14. Another form of furring strip shown in Figs. 7 and 8, consists of a single angled strip 30 with portions 33 of the lower flange slitted and bent alternately left and right, and provided with beads 34 to snap over ribs 37 on the plates. The plates may be made of metal, vulcanized fibre, veneered wood, phenol-condensation products, or other material.

to the front, side or rear. Separate extensions 3 may be attached for wide radiators and a top plate 12 may be provided.

**328,670. Marks, Sir G. C.,** (*Electro Thermal Co.*). Jan. 28, 1929. *Drawings to Specification.*

*Heating by chemical action.*—A rectal dilator is provided with heating means comprising a permeable cartridge containing a mixture of powdered magnesium and cuprous oxide, lead suboxide, or other substance capable of absorbing the nascent hydrogen generated by the action of water on magnesium, together with a quantity of sand, fuller's earth, or like substance. Heat is generated on moistening the cartridge with an aqueous liquid such as water or milk, a graduated liquid measuring cup of adjustable capacity being provided in the stopper of the dilator.

**328,740. Naylor, W. T.** March 18, 1929.

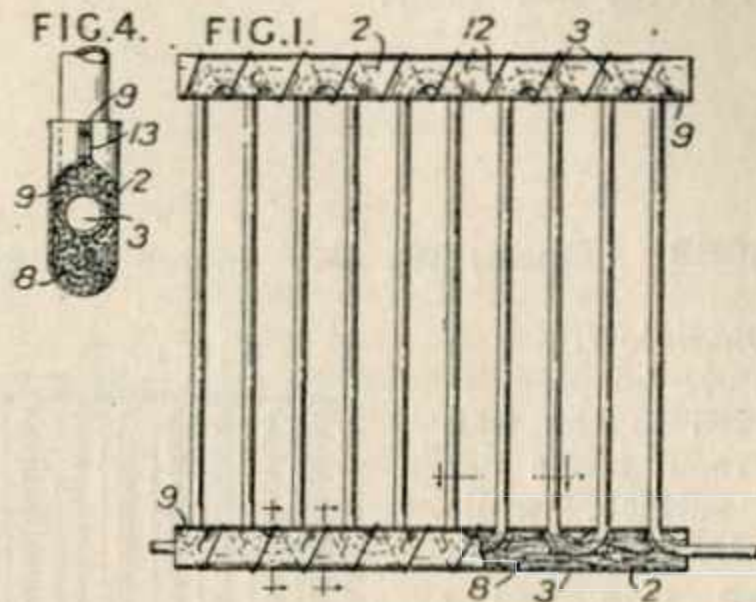

*Radiators.* — In a panel heating system for buildings, employing pipes embedded in concrete, cracking of the concrete due to unequal expansion is avoided by covering the bends of the piping with a sheath of metal, and packing the sheath with a porous compressible material. The sheaths 2 are of U-shape in cross section, and cover the bends 3 of the heating pipes, and are packed with compressible material 8 such as straw, waste paper, felt, fibrous materials, or ground cork. The sides 9 of the sheath may be pressed together between the pipes, so that the complete panel and sheaths may be transported as a unit. Wire 12 may be wound spirally around the sheaths and apertures 13 may be formed to key the concrete. The latter does not penetrate into the packing 8 which may thus become compressed when the piping expands.

**328,703. Bakkekilde, R. S.** Feb. 12, 1929.

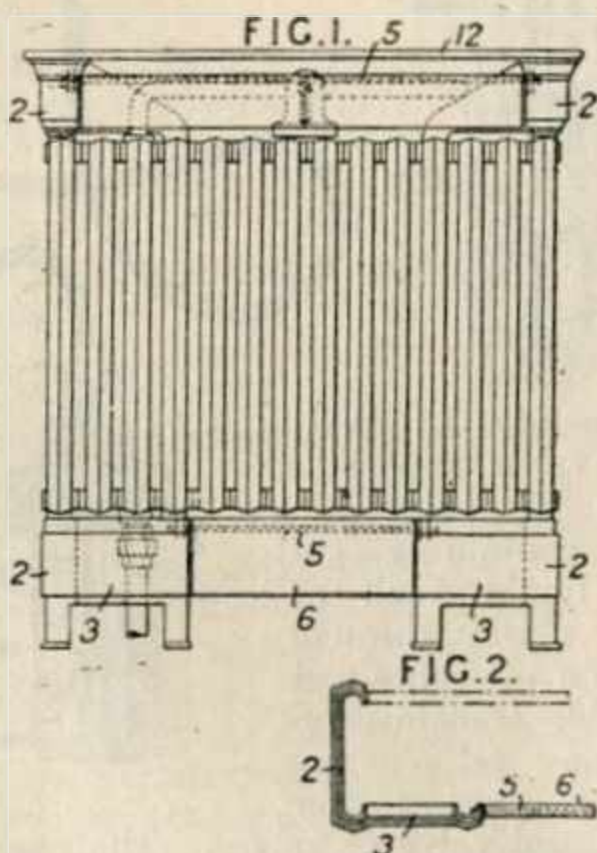

*Radiators.* — Covers are arranged on top and underneath radiators for central heating so as to leave the whole of the heating surface exposed and to conceal pipes and valves. Each cover comprises two side pieces 2 connected by a bolt 5 supporting a fixed or swinging plate 6 covering the space between the side pieces. Each side piece has an extension 3, which may be turned

**328,782. Gerdts, G. F.** April 24, 1929.

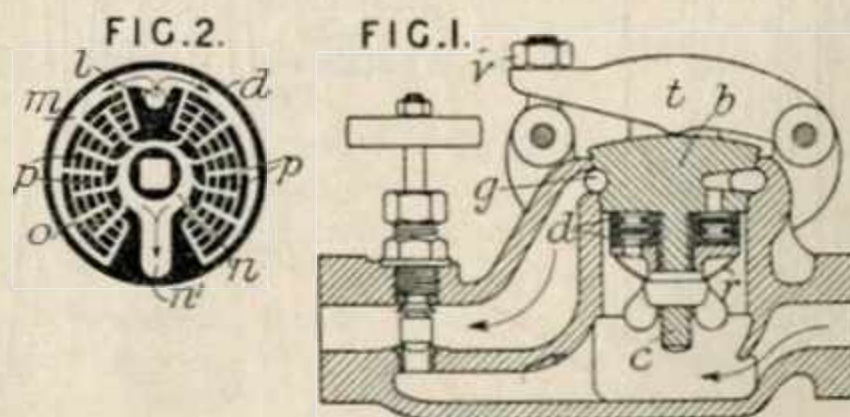

*Steam traps.*—A steam trap comprises a plug b with a circumferential discharge duct g and connected to a steam inlet by baffle plates d of elastic material with low heat conductivity such as that known under the registered Trade Mark "Bakelite" or compressed asbestos forming labyrinthine channels between them. The plug is

held in place by a lever *t* and nut *v* and has a bolt *c* integral with the plug passing through the baffle plates *d* and a strainer *r*. Each plate is flat on one side and the other side is grooved to form a peripheral distributing chamber *m*, a central collecting chamber *n* and radial and concentric channels *o*, *p* connecting the two chambers. A radial extension *n*<sup>1</sup> of the collecting chamber *n* communicates with the inlet perforation *l* of the next plate.

**329,082. Case, W. G.** March 15, 1929.

*Radiators.* — A radiator adapted to be fixed to the wall of a room has a flat rear surface, while the front radiating surface comprises a number of semi-elliptical projecting ribs *C*, each containing heating fluid, and transverse connecting passages *B*. The projections *C* are connected by the flat plate *A* which forms the back of the radiator.

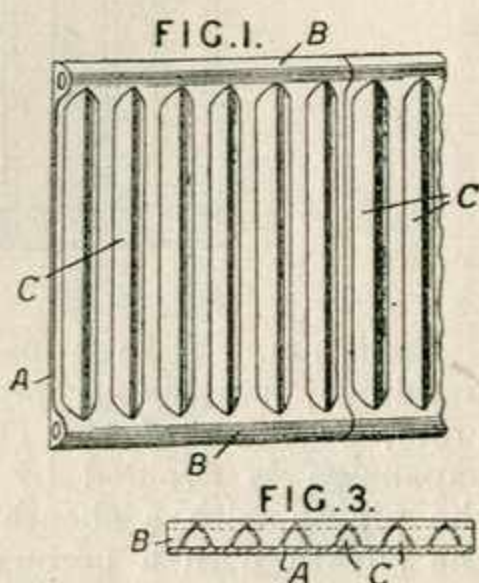

**329,160. Roberts, A. M., and Associated Electrical Industries, Ltd.** May 11, 1929.

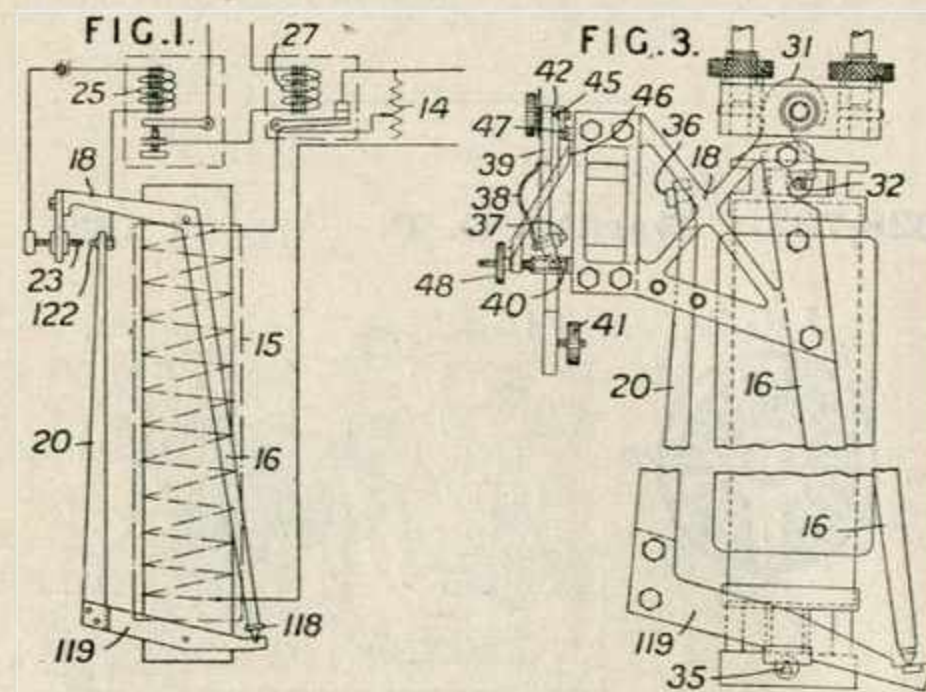

*Thermostats.* — Heat supplied to a container through its walls is controlled by the expansion thereof by means of two L-shaped levers pivoted thereon, one lever not expanding with the casing. The free ends of the levers form or operate an electric switch. An L-shaped lever 20 is pivoted to the casing along its short arm 119 on which bears the end 118 of an L-shaped lever 16 pivoted

at the elbow to the other end of the casing. The lever 16 may be bifurcated; it does not expand when the casing is heated and consists preferably of a non-expandable metal such as that known under the Registered Trade Mark "Invar." The casing expands evenly and consists of steel in Austenitic condition. The two L-shaped levers carry electrical contacts 23, 122 to control the heat supply, e.g. of a coil 15 through relays 25, 27 bringing a rheostat 14 into circuit. The apparatus is suspended from a hook 31, the levers being mounted on knife edges 32, 35. The arm 20 carries a poppet 36 for moving a poppet 37 on a spring 38 on a lever 39 pivoted at 40 on the lever arm 18. The lever 39 carries an adjustable weight 41 and an electrical contact 42 engaging a contact 45 on a lever 46 pivoted at 47 on the arm 18 and adjusted by a screw 48. A bifurcation of the lever 16 may be resiliently mounted on a bifurcation of the arm 119.

**329,360. Berkel, W. A. van.** Jan. 16, 1929.

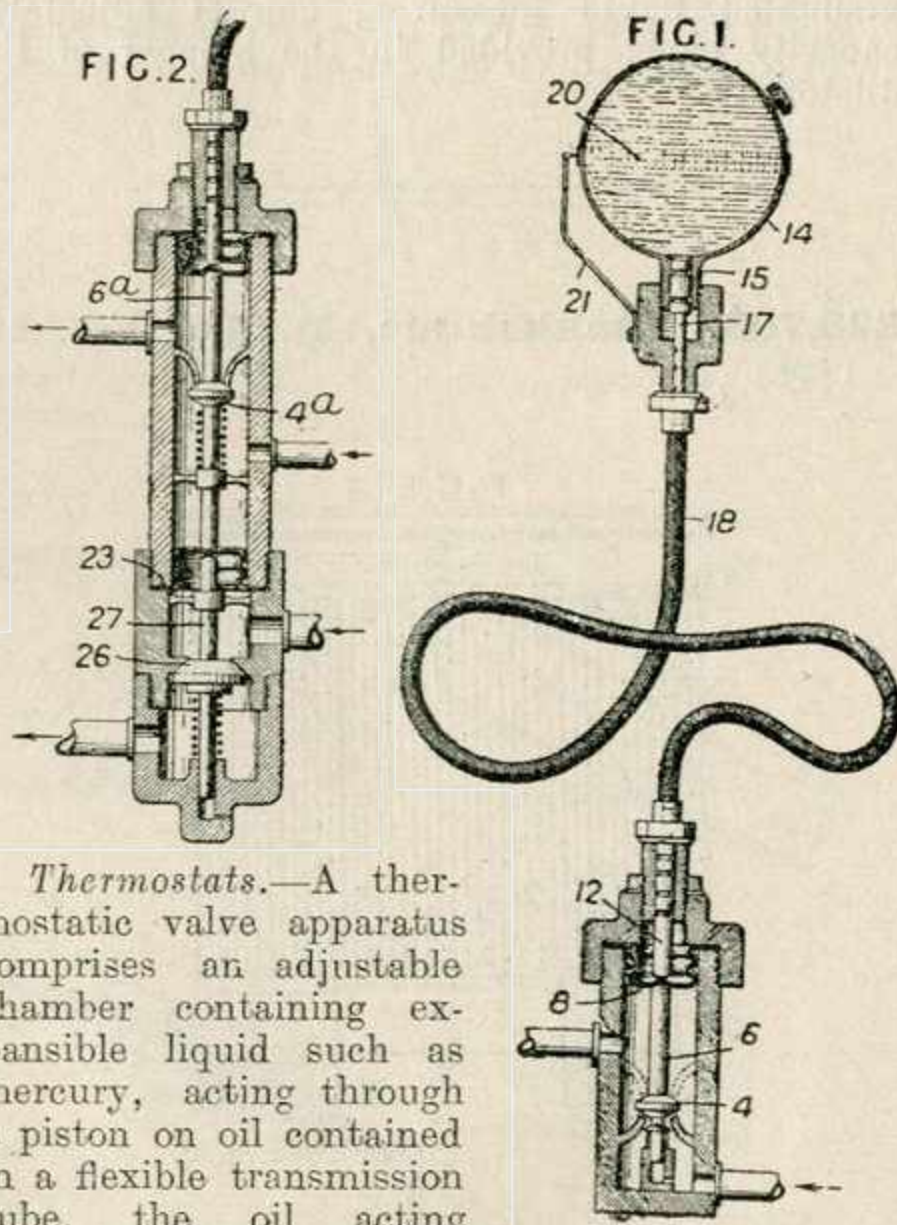

*Thermostats.* — A thermostatic valve apparatus comprises an adjustable chamber containing expansible liquid such as mercury, acting through a piston on oil contained in a flexible transmission tube, the oil acting through another piston on the control valve or valves. The chamber 14, containing mercury, is adjustable by means of the threaded neck 15, and a scale 20 and indicator 21 are provided. Expansion of the mercury is transmitted by a piston 17 to non-volatile, non-freezing oil in the flexible tube 18, at the further end of which another piston 12 is provided. The movement of the latter piston is transmitted through a diaphragm 8 to the spindle 6 of a valve 4. In a modification, Fig. 2, two fluids, such

as ammonia and cooling water in a refrigerating machine may be controlled. The valve 4<sup>a</sup> corresponds with the valve 4 of Fig. 1, and its spindle 6<sup>a</sup> acts through another diaphragm 23 on the spindle 27 of a second valve 26.

**329,502. Roberts, A. M., and Associated Electrical Industries, Ltd.**  
May 14, 1929.

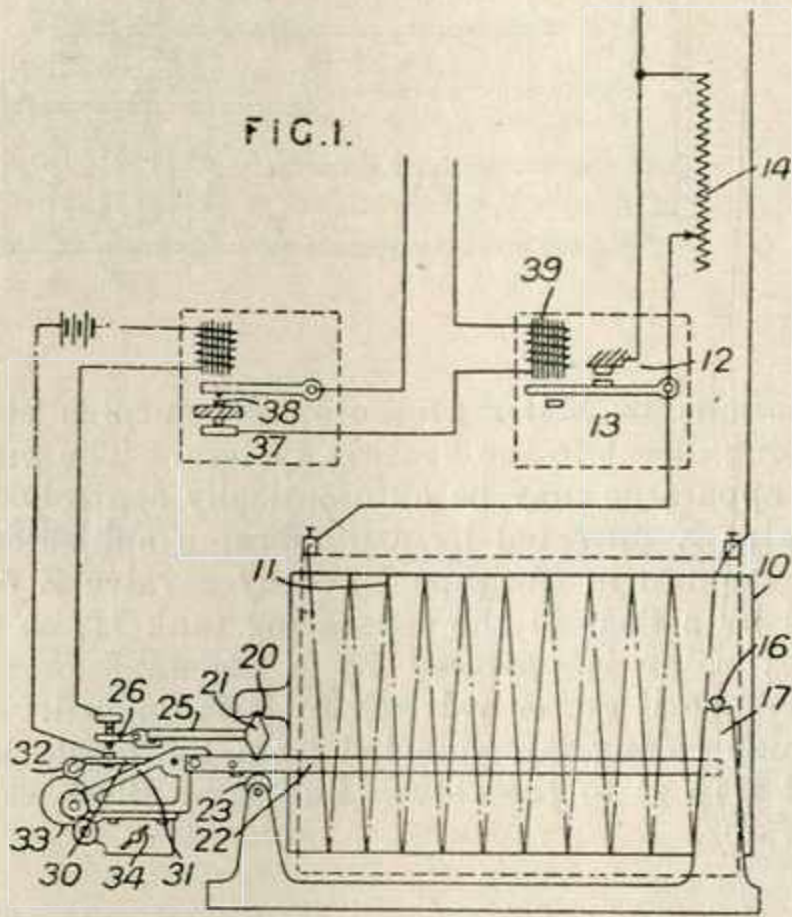

**Thermostats.**—Heat is supplied to a container by means of a heating coil surrounding it, and the expansion of the container is employed to regulate the heating. The container 10, e.g., of steel in the austenitic condition, is heated by a coil 11 in circuit with the contacts 12 of a relay 13, the contacts being shunted by an adjustable resistance 14. The container is supported by knife edges 16 resting on supports 17 at one end, and by a pair of abutments 20 resting on a rocker 21 at the other end. The rocker rests on a pair of rods 22 of material having a low coefficient of expansion, such as that known by the registered Trade Mark "Invar," and the rods 22 are fixed at one end in the supports 17 and rest on rollers 23 at the other end. The rocker 21 carries an arm 25 with a pivoted and adjustable contact 26, and the lower contact 30 is pivoted to a bracket 31 attached to the ends of the rods 22. The member 30 carries a roller 32 bearing on a cam 33 actuated by clockwork 34. When the temperature of the container 10 rises beyond a predetermined point, the contacts 26, 30 are closed, and the relay 37 is energized. The contacts 38 open, and the relay 39 is de-energized, thus removing the short-circuit from the resistance 14 and decreasing the current supply. The temperature at which the contacts 26, 30 are closed is varied throughout a cycle by the clockwork 34.

**329,695. Rooke, N.** Feb. 23, 1929.

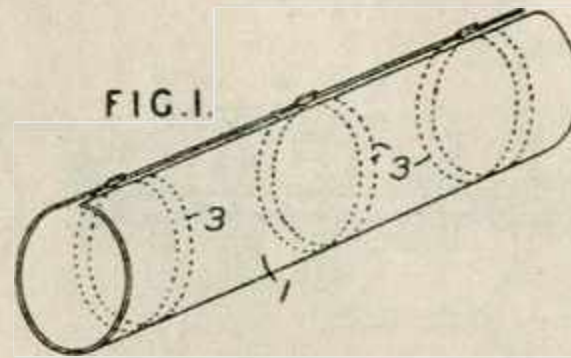

**Nonconducting coverings for heat and sound.**—A protective covering for a pipe comprises a strip 1 of a flexible material—e.g. felt, asbestos cloth—which encircles the pipe and is kept in contact therewith by attached clips which may be split rings 3 as shown or a continuous zig-zag spring; the clips are attached by stitching, weaving or embedding; pockets may be formed for their reception by stitching together a double thickness of material which is afterwards filled with cork dust or other insulating substance.

**329,767. Schierwater, C. A.** April 5, 1929.

**Radiators.**—An air filter for radiators for heating buildings comprises a casing in the form of a hood having depending sides, the top 3 or side 4 of the casing being of wire mesh and hinged. A moistened fibrous pad 5 preferably impregnated with glycerine is held between two perforated plates at the top or front of the casing, or a lining of textile material is inserted, or fine gauze alone is used. The casing is preferably attached at 8 to a wall.

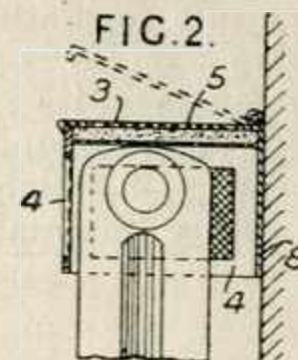

**329,884. Jennings, I. C.** July 4, 1929.

**Heating by circulation of fluids.**—In a vacuum steam heating system, the wet vacuum pumping apparatus is driven by a turbine supplied by low-pressure steam from the same boiler, and the exhaust steam passes into the heating system. A boiler A, Fig. 1, supplies low pressure-steam through pipes A<sup>1</sup>, B, to radiators C, the exhaust from which passes into a return line F and thence to a separating tank H. The pumping apparatus I comprises a hydro-turbine air pump J, Fig. 2, and a centrifugal water pump K. The pump J is connected by pipe J<sup>1</sup>, Fig. 7, to exhaust air and gas from the top of the tank H and deliver through separator L to escape M. Water returns through float valve L<sup>1</sup> to the tank H. The pump K draws water from the bottom of the tank H

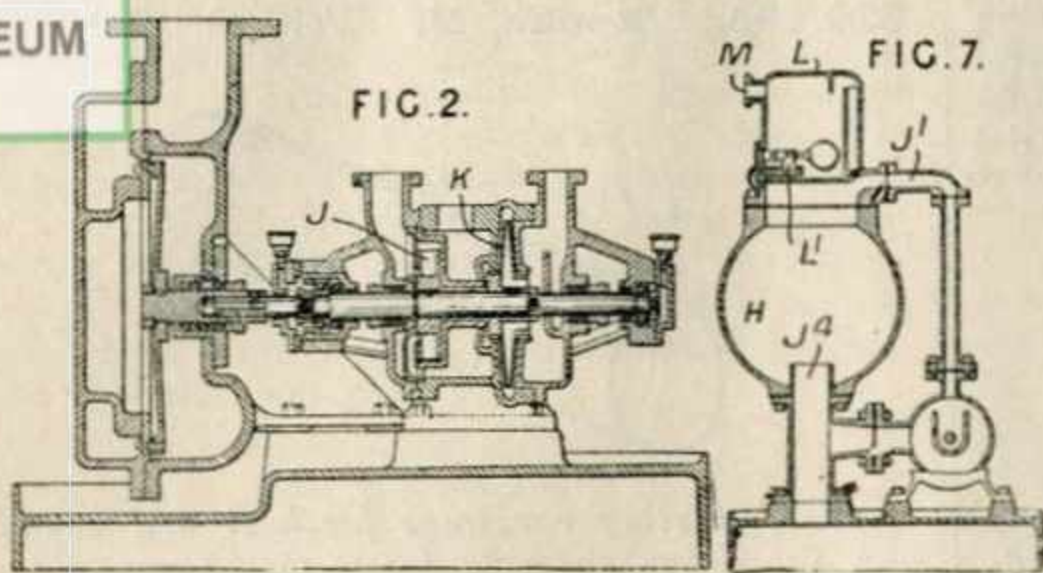

and returns it through pipe N to the boiler. A bye-pass O is provided between the return line F and the boiler. The air pump J is supplied with the water necessary for its operation by a connection opening into the tank H, at a level lower than the connection J<sup>4</sup> to the pump K. Such a system is usually supplied with steam of 4-5 lb. pressure with a partial vacuum of 5 lb. in the return line, such pressure difference being normally too low to drive a steam turbine satisfactorily, but the turbine may be satisfactorily operated if it is provided with a large number of inlet jets or nozzles. The exhaust from the turbine passes through pipe V to the radiator supply pipe B. The necessary pressure difference between the pipes Q, V is maintained by a pressure regulating valve W, at, say, 3 lb. The valve W is operated automatically by the pressures on its two sides acting on opposite sides of a diaphragm, and the setting is adjustable by means of a weight w<sup>2</sup>. The speed of the turbine is thus maintained constant notwithstanding

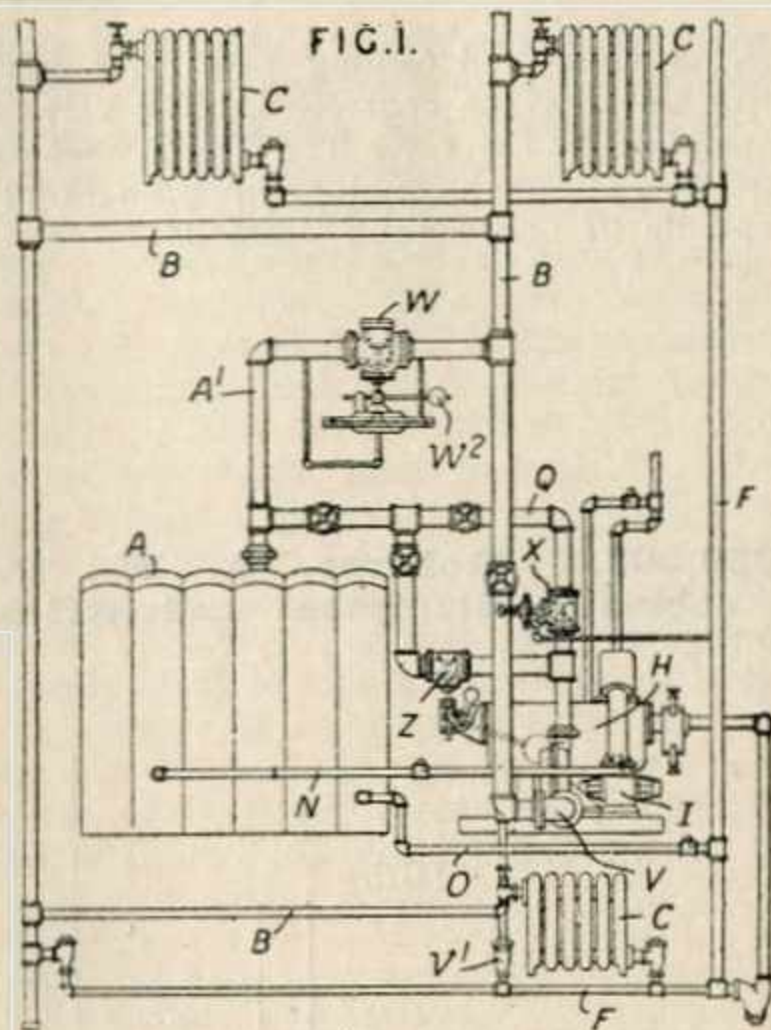

variations in boiler pressure, the surplus steam passing direct to the heating system. The pumping apparatus may be automatically controlled by a valve X operated by a diaphragm subjected to the vacuum in the pipe F, or by a valve Z operated by a float in the separating tank H, so that the turbine is operated by a constant pressure difference if either valve X or Z is opened. The turbine casing is connected by a thermostatic or float trap v<sup>1</sup> to the return line F to allow escape of water.

**330,069. Waller, F. N., and Coombe, G. A.** April 18, 1929.

*Radiators.*—A dust shield for use with a radiator comprises a canopy B covering the top and sides of the upper portion of the radiator and a filter c extending across the upper portion of the front of the radiator and carried by the canopy. A wall A extends from the canopy to the floor on the side opposite the filter. The canopy and wall are formed from one piece of metal and supported on angle irons. The filter comprises copper gauze C in a frame D hinged to or detachable from the canopy.

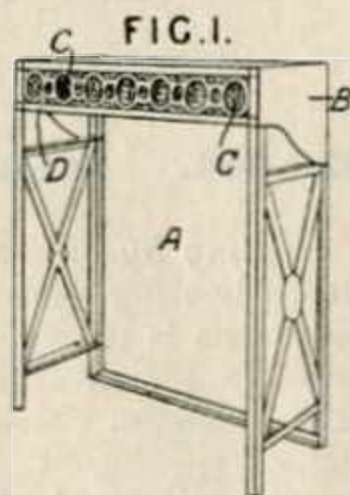

**330,179. Geipel, Ltd., W., and Pell, W. Guy-.** July 26, 1929.

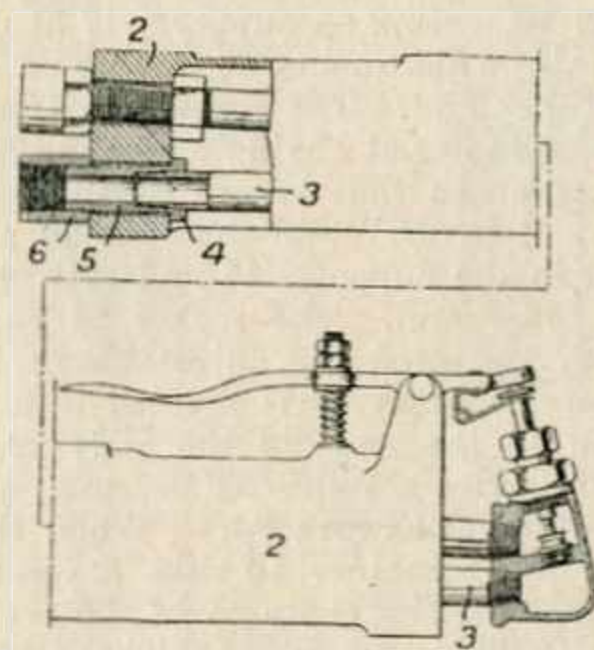

*Steam traps.*—In a steam trap employing the differential expansion of a combination of tubes or a tube and rod, the placing of the threaded end of the tube 3 in tension is avoided by pro-

viding a sleeve 5 into which the tube is threaded. The sleeve has a collar 4 resting against the support 2, and is secured by a socket 6. Slight lateral adjustment of the sleeve 5 is possible, and axial adjustment may be obtained by placing washers under the collar 4.

**330,458. Warschauer, L.**  
April 27, 1929, [Convention date].

*Nonconducting coverings for sound.*—Sheet metal plates 1 for road and tramway vehicle bodies and for vehicle doors are coated with a vibration-damping covering 2 of paper or fibrous or textile material.

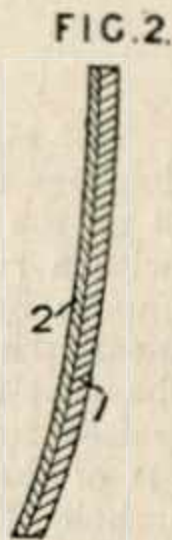

**330,600. Marks, Sir G. G.,** (Automotive Device Co., Inc.). March 11, 1929.

*Thermostats.*—A thermostat T, arranged in an oil purifier to open an oil-inlet valve 37 closed by a spring 41, comprises reversely-curved elements 45, 46 each formed of a pair of strips of different nickel steel alloys having substantially different coefficients of expansion. To reduce friction, the ends 49 of each element are reversely curved, and the edges coact with knife-edges 53 on extensions 52 of the arms of a yoke 51 about

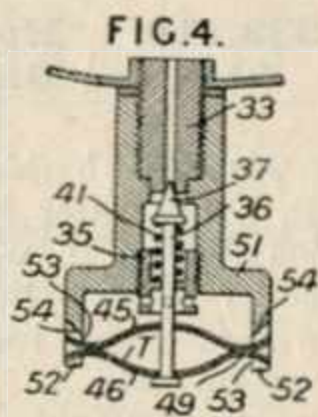

the valve 37. Canting on the valve-stem 36 is limited by knife-edges 54 on the yoke arms.

**331,252. Wilkinson, G.** March 27, 1929.

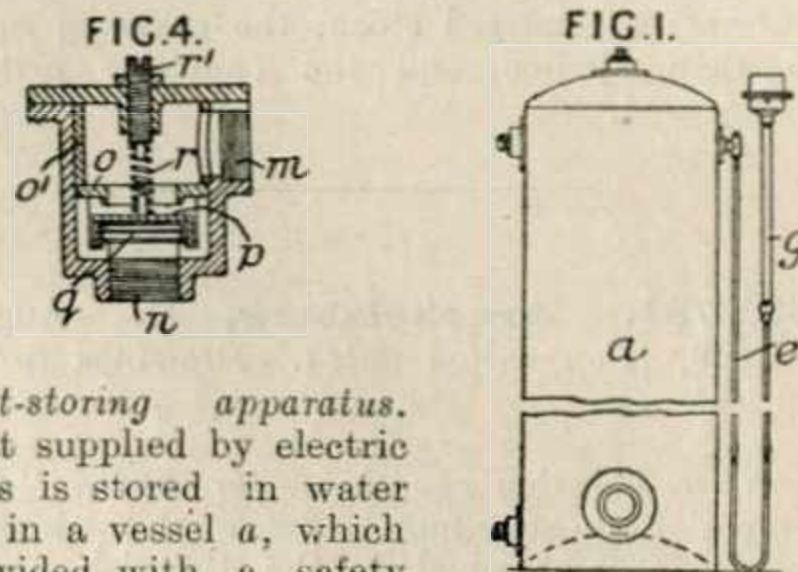

*Heat-storing apparatus.*—Heat supplied by electric heaters is stored in water or oil in a vessel a, which is provided with a safety device comprising a U-tube e containing mercury which is forced into an enlargement g by increase of pressure in the vessel a. The pressure and temperature in the vessel a depend on the head of mercury. The enlarged portion g of the U-tube contains a float provided with any suitable restraining device which ensures that it rises or falls suddenly. The upper end of the rod operates an electric switch which controls the heating circuit. The liquid in the vessel a is used for heat storage only, and the heat is transferred to water or other liquid by conduction. The temperature of the second liquid is controlled by a thermally actuated valve in the circulating return pipe. A suitable valve is shown in Fig. 4, in which the return pipe is connected at m and the outlet to the tank at n. The valve seating o is retained by a liner o', and the valve p is operated by capsules q filled with suitable liquid, which expands on contact with the hot liquid. The temperature at which the valve closes is controlled by a screw r'. In the event of an abnormal rise of mercury in the U-tube, terminals are short-circuited to melt the fuzes in the heating circuit.

**331,561. Arnot, R.** Feb. 4, 1929.

*Nonconducting coverings for sound.*—Sound-proof sheet material comprises one or more layers of a heterogeneous vegetable substance, the fibres of which either cohere naturally or are caused to cohere by compression, together with outside coverings secured by adhesives. The fibrous materials may be wood, particularly balsa wood, or compressed sugar-cane fibre, and the outer coverings may consist of sheets of asbestos cement or reinforced Portland cement or metal, or fireproofed parchmented fibre or canvas. The adhesive used may be that described in Specifications 225,953 and 290,327, [both in Class 22, Cements &c.], or a synthetic resin of the phenol-formaldehyde or urea form-

aldehyde type, or an alkaline silicate to which an alkaline earth or other metal oxide, or Portland cement, is added.

**331,733. Dunlop Rubber Co., Ltd., and Campbell, D. C.** Aug. 20, 1929.

*Hot-water bottles.*—A hot-water bottle of rubber or material having rubber as the principal constituent, has an external surface in which woolly or fleecy material is incorporated. The sheet rubber stock may have the covering material incorporated with it, and the bottle may



**ULTIMHEAT<sup>®</sup>**  
**VIRTUAL MUSEUM**

then be formed of this material and vulcanized. Alternatively, the sheet stock is covered with a film of rubber and the covering material may have a film of rubber on one face, the two being calendered together to constitute stock from which the bottle is manufactured. In another alternative, the bottle is manufactured from ordinary calendered stock, the covering material is then applied, and the complete article is vulcanized.

**331,791. Brackelsberg, C.** Aug. 20, 1929, [Convention date]. Drawings to Specification.

*Nonconducting coverings for heat.*—"Molera stone," a nonconducting material made from a porous clay obtained in the Swedish island of Mors, is used to form a heat-insulating covering for a rotary furnace.

**331,910. Kränzlein, G., and Samesreuther & Co., Ges.** April 9, 1929. Addition to 309,445.

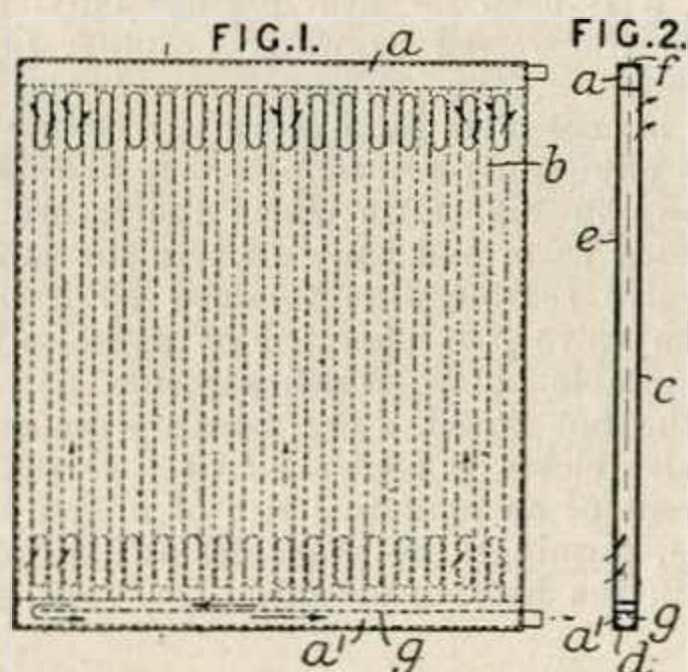

*Radiators.*—The heat-exchanger of the parent Specification is modified in that the pipes *b* and headers *a*, *a'* are enclosed within two flanged plates *c*, *e* which are in heat-conducting contact with the pipes. The plate *c* is flanged at *d* and the plate *e* at *f* and the contacting edges are welded. The discharge header *a'* has a horizontal partition *g*, by which steam entering the upper header as a heating fluid, after passing through the tubes is compelled to travel the whole length of the lower header. Electrical heating devices may be fitted between the tubes to heat fluid in the tubes.

**331,984. Ziele, H.** May 13, 1929.

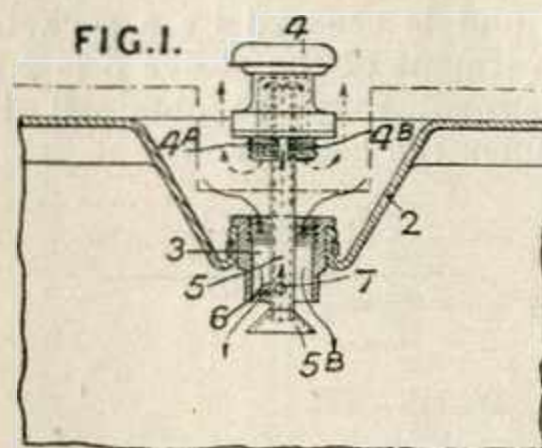

*Hot-water bags.*—The top edge of a hot-water bag has a recessed pocket 2 with a metal sleeve 3 at the bottom into which screws a stopper 4 with a rigid dependent tube 5 which has a bell mouth bottom 5<sup>B</sup> wider than the sleeve and has near the bottom two pins 7 to engage with bayonet slots 6 in the sleeve when the stopper is raised for filling the bag. The external thread 4<sup>A</sup> of the stopper is interrupted as at 4<sup>B</sup> or has a hole therein for escape of air and steam, which passes up the tube.

**332,110. Hope's Heating & Lighting, Ltd., and Bassett, C. T.** Aug. 23, 1929.

*Heating buildings.*—In a hot-water heating installation in which a boiler *a* supplies hot water to a radiating system and to a hot water supply tank, either of the two flow or return pipes *c* and *b* may be connected to the boiler through a cross pipe *d* and a pipe *e* provided with a valve *f* controlled by an electrical device *g*, which is controlled by thermostats dependent on the temperature of the radiating system and of the hot-water tank. The pairs of valves *h* and *j*, and *i* and *k* serve to divert through pipe *e* the water of the system with the thermostat which is controlling the valve *f*, the water of the other system passing straight to the boiler. The pairs of valves *i*, *k* and *h*, *j* may each be replaced by a single multi-way valve.

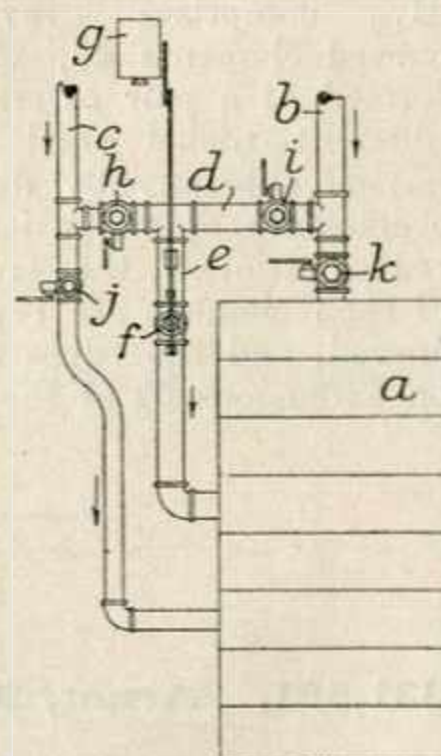

332,229. **Barker, A. H.** April 16, 1929.

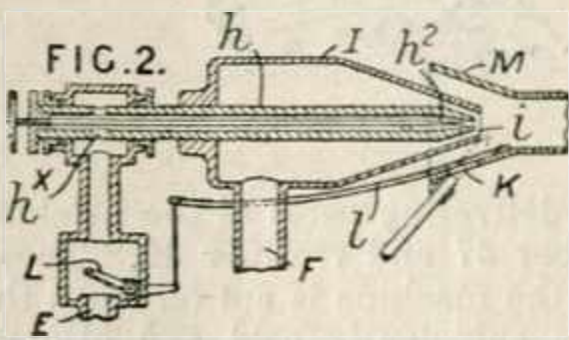
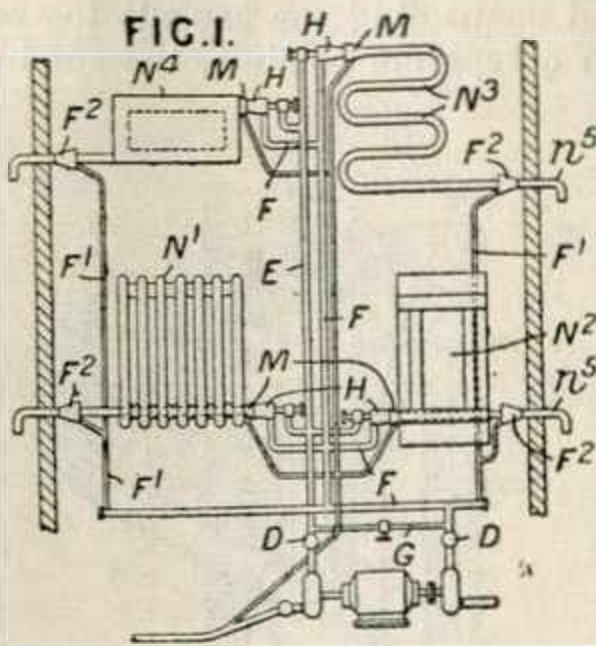

*Heating buildings.*—In heating systems comprising radiator elements traversed by the combustion products from gas burners, the combustible gas and the secondary air for supporting

combustion are admitted separately to the burners under pressure at or above that of the atmosphere and are caused to intermix at the ignition point. The burners H are supplied with combustible gas and air under pressure through pipes E and F respectively provided with automatic pressure regulating devices D, D. Primary air may be supplied to the gas by the cross connecting pipe G. The burner comprises a tubular member *h* communicating with the gas supply pipe E through lateral openings *h<sup>x</sup>* and an outer duct I supplied with secondary air through pipes F, the two supplies intermixing at the place of ignition. The gas supply is controlled by a needle valve *h<sup>2</sup>*; the secondary air supply by the orifice *i* which is varied by the retarding or advancing of the tube *h*. The pilot flame K impinges on a bimetallic strip *l* so that when it is extinguished the flexing of the strip causes a valve L to cut off the flow of gas. The system may include various types of heating devices N<sup>1</sup>, N<sup>2</sup>, N<sup>3</sup>, N<sup>4</sup>, the hot gaseous products from the burners entering by trumpet mouths M. The exhaust outlets *n<sup>5</sup>*, preferably detachable, discharge directly into the open air or into a vertical draught inducing pipe. A by-pass branch F<sup>1</sup> of the secondary air supply pipe may discharge into an ejector F<sup>2</sup> to increase the draught. The secondary air blast may pass wholly to the ejector so as to induce a flow of atmospheric secondary air to the burner nozzle.

332,451. **Marconi's Wireless Telegraph Co., Ltd.,** (Hansell, C. W.). Sept. 12, 1929. [A Specification was laid open to inspection under Sect. 91 of the Acts, Oct. 3, 1929.]

*Thermostats.* — The temperature of a piezoelectric crystal is maintained constant by regulating the temperature of a stream of gas surrounding the crystal. Fig. 1 shows a closed-circuit system in which a blower 18 delivers air, hydrogen, or helium to a chamber 16 enclosing the crystal unit 4. The gas passes through inlets 12 in the insulated electrodes 6, 8, flowing round the crystal 2 to the outlet 14 from which it may pass back to the blower through a radiator 15. The pressure and temperature in the chamber 16 may be kept constant by a device 20 controlling the blower and a heater 22 controlled by a regulator 24. Alternatively a suction blower may be connected to outlet 14 and a thermostatically controlled heater arranged in the conduits as indicated by 20<sup>1</sup>, 22<sup>1</sup>. In Fig. 2, the crystal temperature is kept constant by means of a resistance heater 42 and source 44, the heating circuit being controlled by relay 46 actuated by a thermometer 48 which is embedded in the crystal holder.

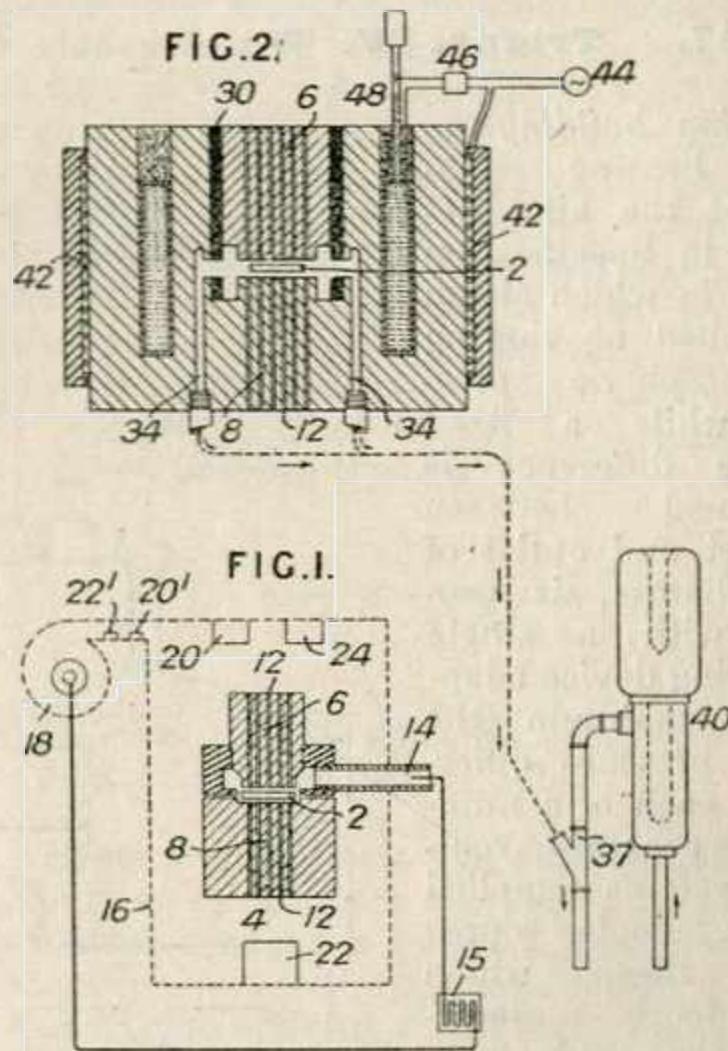





332,653. **Dunlop Rubber Co., Ltd., Brown, L., and Warren, F. W.** May 2, 1929.

*Hot-water bottles.*—A moulded seamless rubber hot-water bottle is constructed with a fabric reinforcement, which in the body part is in the form of both warp and weft 1, but above this consists of weft 2 only, so that the neck may be stretched laterally for withdrawal of the moulding core. In addition, shallow internal ribs 3 may be provided at the neck portion as extra reinforcement. The edges of the bottle are held together by rims on the external moulds.

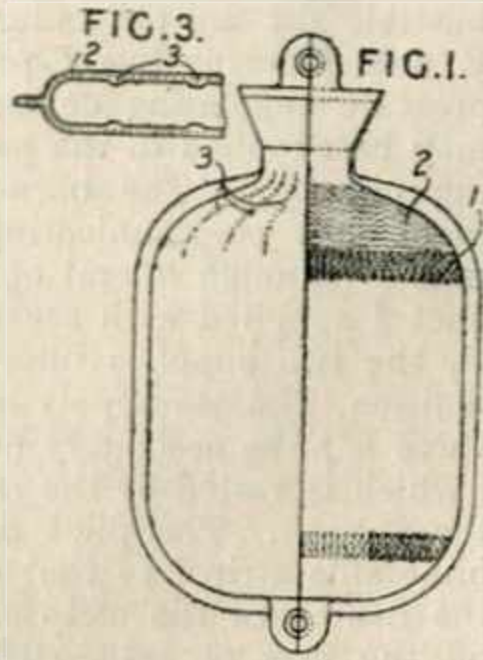

332,655. **Electrolux, Ltd., (Platen-Munters Refrigerating System Aktiebolag).** May 3, 1929.

*Thermostats.*—The pressure in a chamber 17 of a regulating device of a refrigerating machine is influenced by the pressure of a fluid in a cap-

sule 3 mounted on the cooling-member 6 and also in the same sense by the pressure of a fluid in a conduit 4 connecting the capsule to the chamber 17, or in a separate conduit, the conduit passing

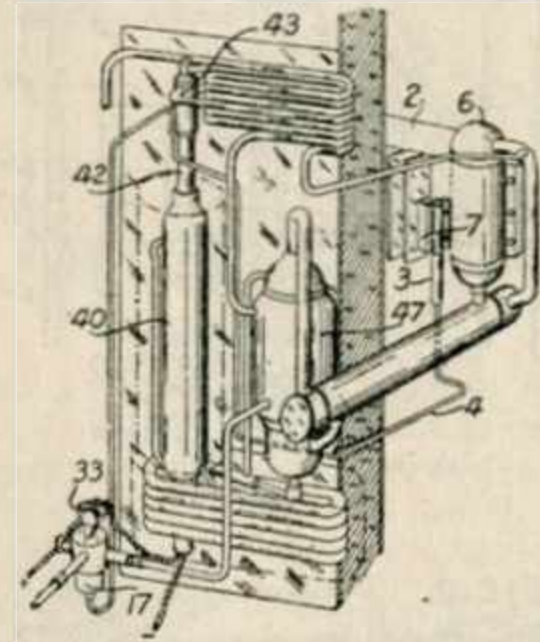

near heat-delivering parts of the machine such as the absorber 47 and rectifier 42. Thus the heat supply to the machine is cut off when the cooling-member is sufficiently cold and also when heat delivering parts are overheated. A separate capsule may be used with the separate conduit for the warm parts of the machine. The capsule on the cooling-member may contain water which is more or less frozen and may be of steel covered with aluminium by spraying. Specifications 297,836 and 308,773, [both in Class 29, Cooling &c.], are referred to.

332,747. **Triggs, W. W., (Dunham Co., Ltd., C. A.).** July 26, 1929.

*Heating buildings.*—Steam heating apparatus of the kind described in Specification 291,134 in which steam is supplied at varying sub-atmospheric pressures while a fixed pressure difference is maintained between the inlet and outlet of the radiators, is provided with a single exhausting device adapted to maintain the desired pressure difference in each of a number of separate radiating systems supplied from a single source through means which independently determine the sub-atmospheric pressure in each system. Steam is supplied from a generator A, Fig. 1,

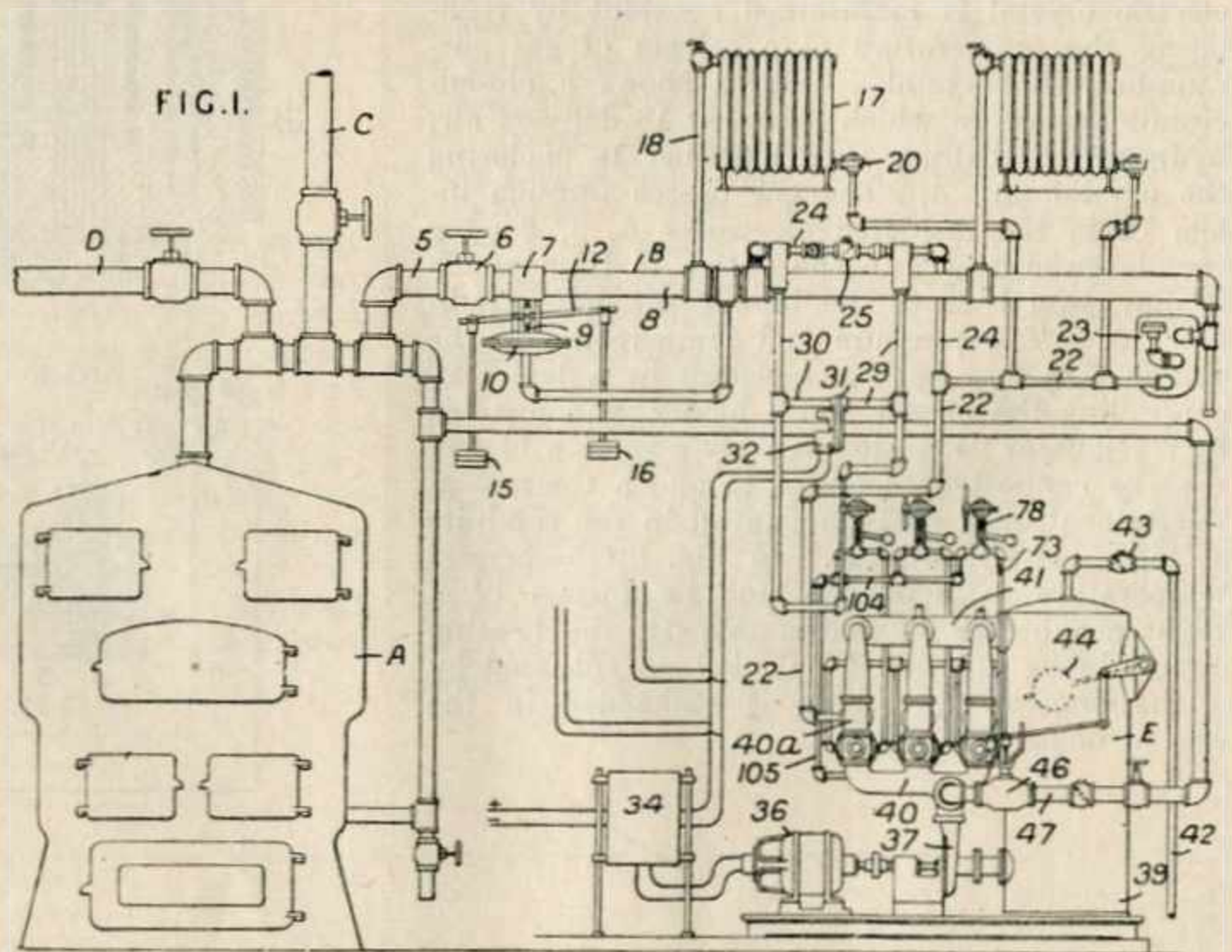

to three separate radiating systems B, C, D, associated with a single exhausting device E. The supply main 5 is provided with a cut-off valve 6, normally open, and a reducing valve 7 which may be controlled by a diaphragm in a casing 10, subject to the pressure in the main 8 on one side and to atmosphere on the other side. The pressure in the main 8 is determined by adjustment of the weights 15, 16 acting through lever 12 on the stem 9. Steam passes to each radiator 17 through a pipe 18, and a thermostatic steam trap 20 is provided between the radiator and the return main 22 to allow condensate only to escape from the radiator. Condensate in the supply main 8 is also returned to the return main 22 through trap 23. An equalizing pipe 24 with non-return valve 25 is provided between supply and return mains. Pressure control pipes 29, 30 extend to a differential pressure controller 31 which may be constructed as described in Specification 291,134. When the pressure difference falls below the desired minimum, a switch 32 is closed, the motor-starter 34 actuated, and the motor 36 and exhausting device E started. Each radiating system is provided with its own controller 31, so that the motor 36 is operated as long as any one of the switches 32 is closed. The motor 36 drives a centrifugal pump 37 which draws water from a tank 39 and delivers it into pipe 40 and thence through one or more of the ejectors 40<sup>a</sup> and pipe 41 back to the tank 39. Air which is withdrawn from the radiating system by the ejectors escapes through pipe 42 and check valve 43. Condensate accumulates in the tank 39 until a float 44 opens valve 46 in a pipe 47, when water is delivered by the pump 37 through the pipe 47 back to the generator A. An ejector unit is shown in Fig. 4. The casing 50 is mounted on the inlet pipe 40, and the water from nozzle 54 and condensate and air drawn in at 57 are discharged at 58 into the pipe 41. The stem 62 of a valve 61 is secured to diaphragms 65, 67, the space between which is open to the atmosphere. Pipes 73, 74 admit and discharge a control pressure fluid, preferably water, the pipe 74 having an apertured plate 75 to allow pressure to be built up in the chamber 69. The pump pressure maintains the valve 61 closed, unless sufficient pressure exists in the chamber 69 to open the valve. Pressure fluid is admitted to the chamber 69 by a pilot valve 78, Figs. 1 and 5, in which a valve member 83 controls the passage of pressure water from the main 40 through pipe 104, 105 to pipe 73 leading to the chamber 69 in the ejector unit. The valve stem 85 projects through stuffing box 87, and is connected to a yoke 88 through which a pivoted weighted lever 89 projects. An up-

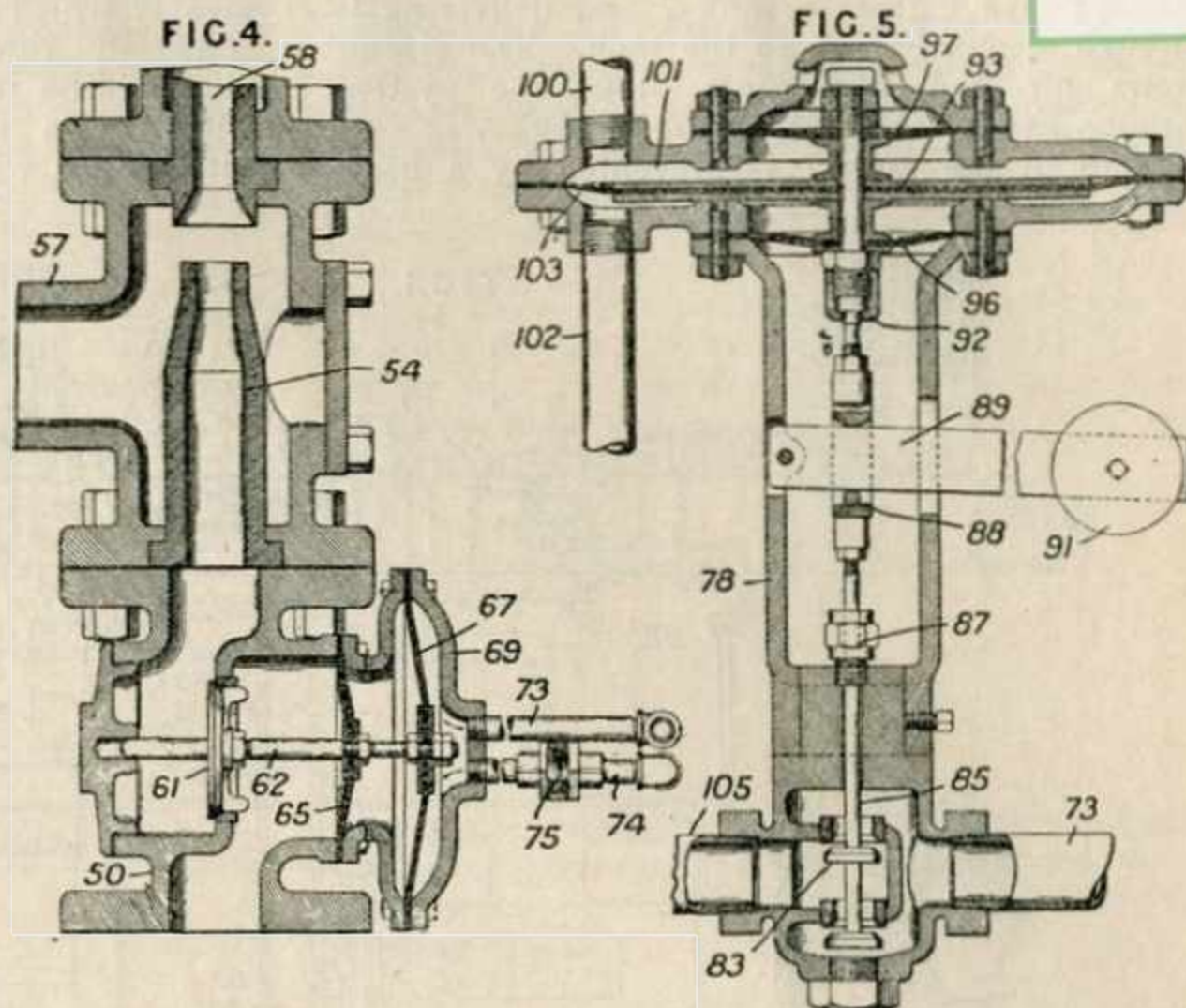

ward extension 92 of the valve stem is connected to an operating diaphragm 93, arranged between two smaller diaphragms 96, 97 which take the place of stuffing boxes, and are subjected on their outer sides to atmospheric pressure. The low and high pressure sides of the radiating system are connected by pipes 100, 102 to the chambers 101, 103, so that the diaphragm 93 is subject to differential pressure. When this falls below the desired minimum, the weight 91 opens the valve 83, admitting pressure fluid to the chamber 69, Fig. 4, and allowing the ejector to operate to restore the required pressure difference. The various radiating systems B, C, D have their reducing valves 7 set according to the heat requirements, and a constant pressure difference is maintained in each system by its pressure controller 31, switch 32, and the common motor-pump unit 36, 37. The controller 78 of each radiating system determines whether the ejector associated with that system shall be effective or not, while the controller 31 starts the pump unit if not already operating in connection with another radiating system.

**332,748. Triggs, W. W.,** (Dunham Co., Ltd., C. A.). July 30, 1929.

*Heating buildings.* — A steam heating system supplying steam from one source to two separate radiating systems is provided with means including a single exhausting mechanism for simultaneously maintaining a different sub-atmospheric pressure in each of these systems. The boiler A supplies steam to a header 1 and thence to pipes H, H<sup>1</sup> supplying separate radiating systems L, L<sup>1</sup>. The exhausting mechanism comprises a motor-driven centrifugal pump 5 drawing water



and pressure than  $L^1$ , the switch 87 is closed so as to place the controller N in control of the motor E, and the switch 87<sup>1</sup> is closed so as to place the controller N<sup>1</sup> in control of the solenoid valve F. The valves are set so that the return main M discharges into the tank D and thence to the exhauster B, while the return main M<sup>1</sup> discharges into the tank C. The reducing valves K, K<sup>1</sup> are set so that the supply main H<sup>1</sup> is at a higher sub-atmospheric pressure than the supply main H, and the outlet 70 from the tank C discharges into the main H when the valve F is opened. If the pressure difference in the

system  $L^1$  is too small, the controller N<sup>1</sup> will close switch 86<sup>1</sup> and open solenoid valve F to place the tank C (which communicates with the discharge main M<sup>1</sup>) temporarily into communication with the main H which is at a lower pressure. Condensate in the tank C is thus re-vaporized and passes into the main H. When the pressure difference between the tank C and supply main H is insufficient, the valves are set so that the tank C is connected directly to the return main of the lower pressure system. Alternatively, both the radiating systems L, L<sup>1</sup> may be operated at the same pressure.

**332,951. Hobson, W.** Feb. 27, 1929.

FIG. 1.

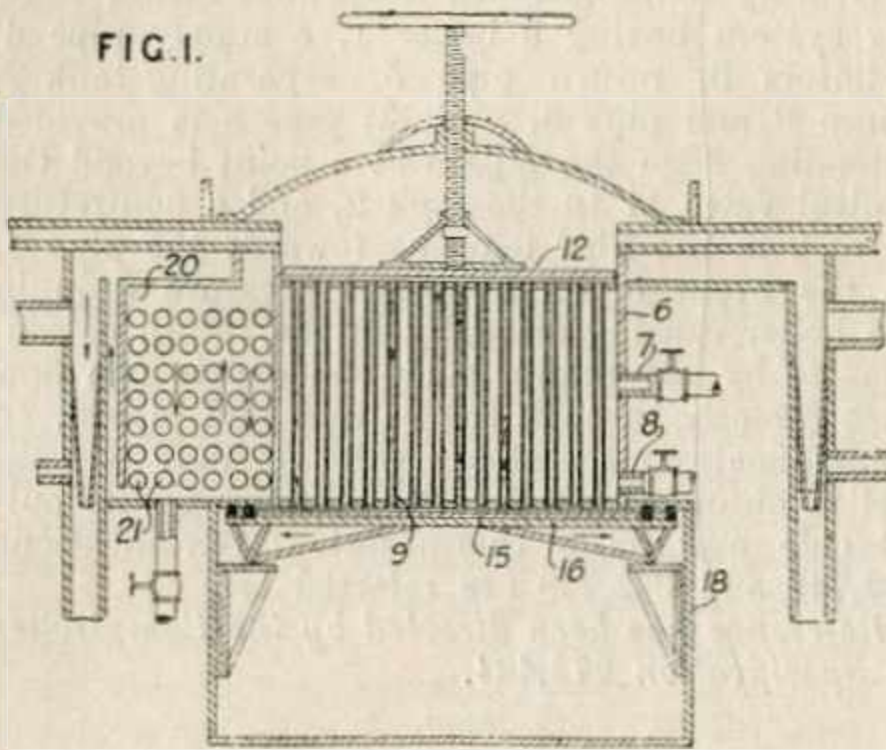

*Heating systems.* — In apparatus for drying, heating, and evaporating, and comprising one chamber in which material is treated by a hot medium, and another chamber in which material is treated by the hot waste products arising from the material in the first chamber, each of the chambers has a series of tubes or cylinders to contain the material and a movable bottom to facilitate discharge. A chamber 6 with steam inlet 7 and outlet 8 contains a series of tubes 9 adapted to dry clay or other plastic material which is forced in by a ram 12; the movable bottom 15 is carried by a trolley 16 mounted on rails in the base 18 of the apparatus. The steam or hot gas issuing from the clay &c. is drawn through a chamber 20 containing tubes 21 through which air or gas is passed to serve as the heating-agent in the second drying-chamber. The tubes or containers may be porous or perforated, and may enclose holders made of wire, filter cloth, &c. In a modification, the ram is replaced by means for applying hydraulic or

pneumatic pressure; and in another form a chamber is arranged to dry the air or gas by refrigeration or otherwise before reaching the heating-tubes.

**333,014. Benson, H. S.** June 25, 1929.

*Thermostats.*—In a circuit-closing device of the kind in which mercury in a U-tube is moved by the expansion or contraction of a liquid above it to engage electric contacts, each limb of the U-tube is provided with a cock by which the mercury can be isolated in the U-tube. The metal U-tube A, filled with mercury, is joined through a cock B<sup>1</sup> and unions a, H to a tube J which is closed by a cap K and contains air at atmospheric pressure. The other end of the U-tube is joined through a cock B and unions a, b to an inverted U-tube C, provided with a closed chamber D and containing an expansive fluid. The cocks, Fig. 2, are of metal with an insulating sleeve m through which a contact wire p passes into the bore g.

FIG. 2.

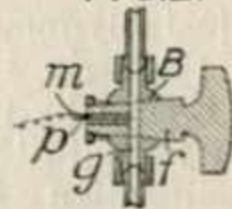
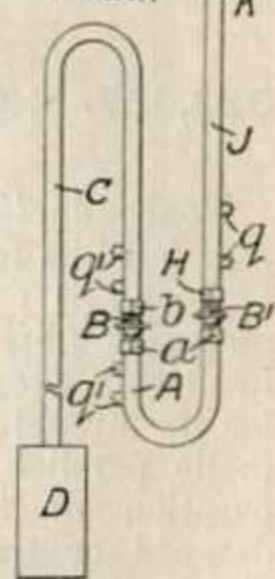

FIG. 1.



When the fluid in the tube C expands, the mercury is moved to engage the contact in cock B<sup>1</sup>, the metal U-tube A forming the return lead of the circuit. In case of contraction of the fluid, the mercury closes a circuit through the contact in cock B. Further contacts q and q<sup>1</sup> may be provided for the indication of different degrees of temperature.



ULTIMHEAT®

VIRTUAL MUSEUM Evershed & Vignoles, Ltd.,  
and Perry, C. E. Aug. 2, 1929.

CLASS 64 (ii), HEATING SYSTEMS &c.

334,035. Jennings, I. C. Aug. 7, 1929.

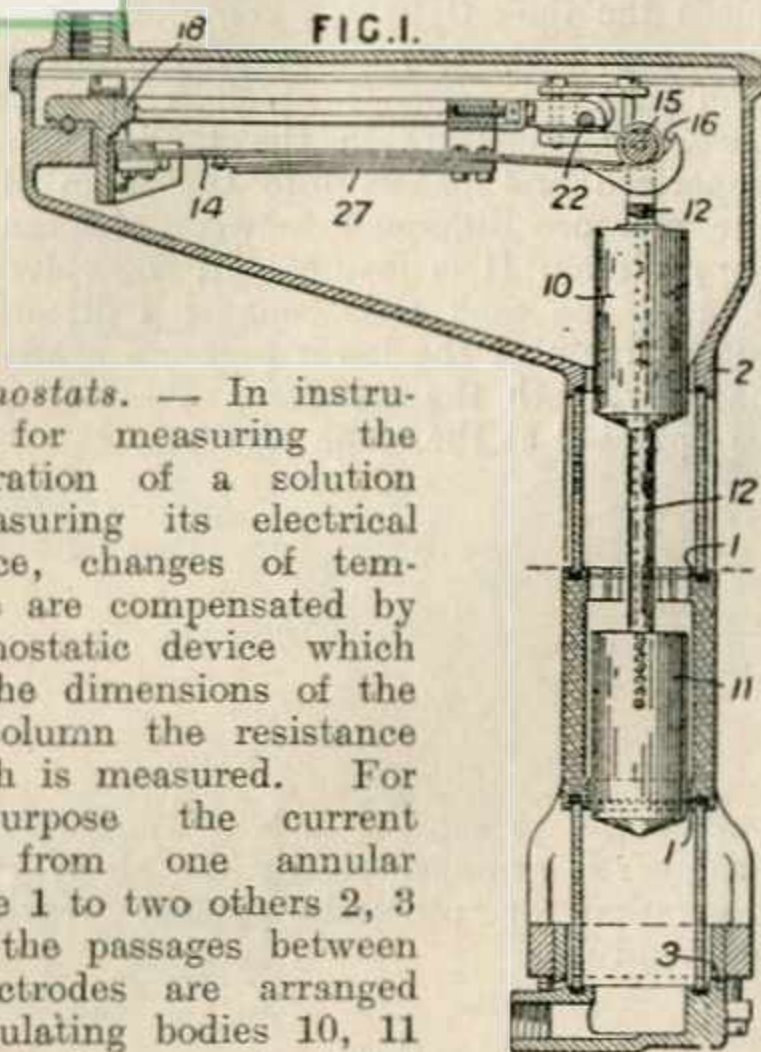

**Thermostats.** — In instruments for measuring the concentration of a solution by measuring its electrical resistance, changes of temperature are compensated by a thermostatic device which alters the dimensions of the liquid column the resistance of which is measured. For this purpose the current passes from one annular electrode 1 to two others 2, 3 and in the passages between the electrodes are arranged two insulating bodies 10, 11 connected by an insulated rod 12 on which is mounted a roller 15 carried on a member 16 supported by a bimetallic strip 14. The member 16 is curved to such a shape that the roller 15 moves in a vertical path as the strip 14 bends. The strip 14 is carried on a pivoted member 18 which also carries a second adjustably-mounted bimetallic strip 27 bearing on the strip 14 as shown. The member 18 can be rocked by means of an eccentric pin 22 which can be adjusted from outside the apparatus. A modification having two electrodes and one movable insulating body is described.

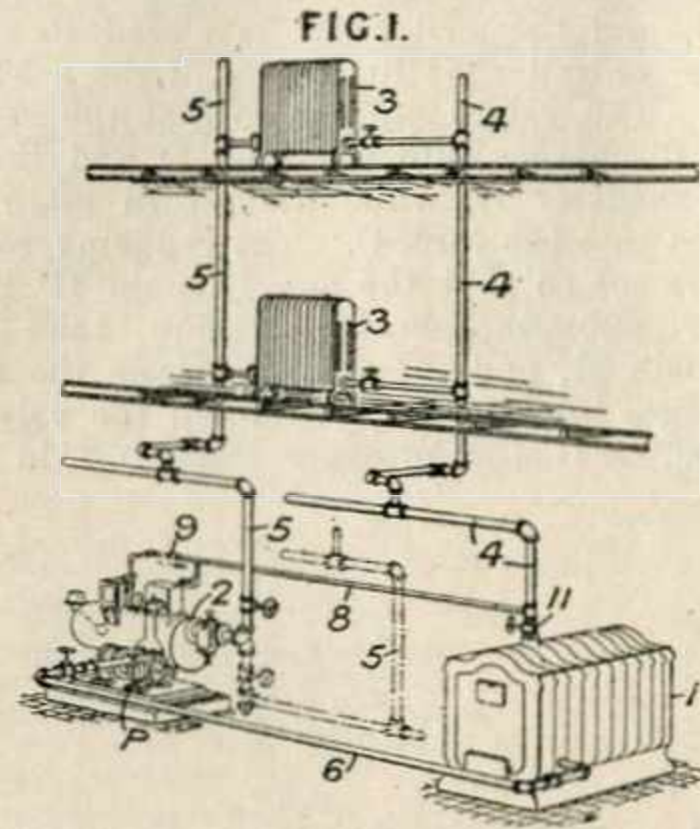

**Heating buildings.**—In a vacuum steam heating system having a boiler 1, a supply pipe 4, radiators 3, return pipe 5, separating tank 2, pump P and pipe 6, a shunt pipe 8 is provided extending from the pipe 4 at a point beyond the control valve 11 to the tank 2, and a non-return valve 9 in the pipe 8 opens towards the pipe 4. In the event of an abnormal pressure drop in the boiler causing difficulty in the return of condensate by the pump, such condensate can flow back directly through the valve 9 and pipe 8. In a modification, the steam valve 11 may be controlled automatically by the pressure on its outlet side and by a thermostat. Specifications 332,747 and 332,748 are referred to.

Reference has been directed by the Comptroller to Specification 272,484.

333,957. Bohlander, H. May 28, 1929.

**Nonconducting coverings for heat and sound.**—A felt-like material for insulating against heat or sound is composed of two different kinds of inorganic fibre, one of which is selected for its insulating properties while the other is chosen for its strength. Preferably, the fibres are made to lie parallel with one another during the preparation of the mixture, and they may be damped or treated with a binding material to cause them to set firmly together. Slag wool, for example, can be mixed with a stronger fibre such as asbestos, and the mixture can be immersed in an aqueous solution of starch or water-glass. Powdered materials, such as kieselguhr or magnesia, can be added to the mixture, and a quick-drying binding material can be added before or during preparation. The resulting mass can be brought to the required degree of density or porosity by pressure. The fibrous materials can also be felted together by submitting the mixture to a current of steam or moist air with which the binder can be mixed by spraying. Alternatively the binder may be mixed with the fibres before they are treated with steam.

334,127. Associated Electrical Industries, Ltd., (Assignees of Bierens, R.). Nov. 9, 1928, [Convention date].

**Radiators for heating buildings.**—A radiator is constructed by forming riser members 1 from two flat metal plates welded together at their edges 3, and if desired at intermediate lines 4, and then deformed as described in Specification 304,689, welding the edges of the openings to corresponding openings 6, Fig. 3, in a plate 5 of trough like section, and then bending the sides of the troughs and welding their edges together so as to form headers uniting the ends of the riser members.

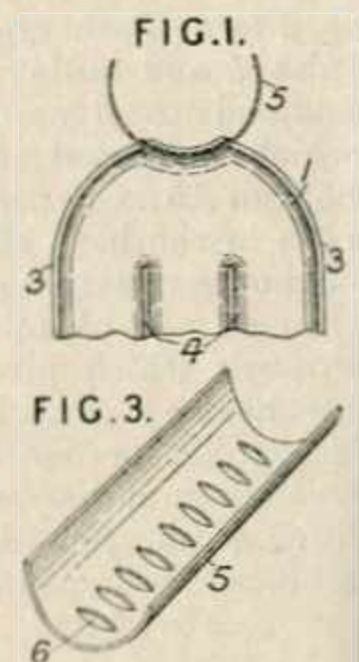

**334,326. Barty, T., Brackenbury, A. G., and Westinghouse Brake & Saxby Signal Co., Ltd.** July 11, 1929. *Addition to 286,782.*

*Radiators.* — The steam heating apparatus for railway vehicles described in the parent Specification is modified to make the valve more readily accessible. The outflow and return conduits 1, 2 are connected to a casing member 4 having a steam inlet 5 and drain passage 8. A valve member 7 is mounted in a cylindrical member 9 adapted to slide axially in the casing 4, and a packing 10 pressed by a spring is provided to prevent escape of steam. A pair of rods 12 extend one along each side of the conduit 2, and pass through and are secured to a member 11 engaging in a transverse recess in the casing 4. The position of the valve 7 relatively to its seating is adjusted by means of the nuts 13, and the valve controls the steam

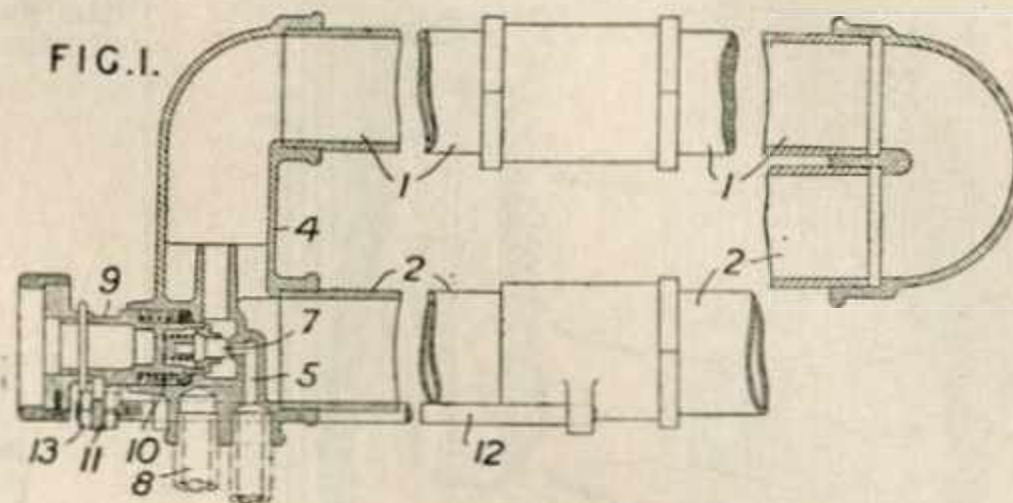

inlet automatically by means of the difference in expansion between the conduit 2 and rods 12. The member 9 carrying the valve 7 may be withdrawn for inspection or repair by removing the nuts 13 from the two rods 12.

**334,349. Wolters, E. C. W.** Jan. 28, 1929, [Convention date].

*Hot-water bottles.*—An indiarubber hot-water bottle is provided with one or more transverse internal partitions 63, 64 moulded integrally with the bottle. The partitions do not extend entirely across the width of the bottle, and are formed by the use of a steel moulding core 62 having rounded slots 63, 64. The indiarubber sheets forming the sides penetrate, during vulcanizing under pressure, into the slots from both sides, and unite to form the partitions. The edge of the bottle between 67—68 is not closed during moulding, and the core is subsequently withdrawn through this opening which is afterwards closed by a separate operation.

The Specification as open to inspection under Sect. 91 (3) (a) describes also an indiarubber hot-water bottle Fig. 1, (*Cancelled*) having four groups of pin-shaped projections 14 on its flat sides to prevent excessive transmission of heat to the user. The smooth parts 27 may be used for the reception of fastening bands. Other groups of projections 15 may be provided on the inside of the bag to prevent the sides sticking together. External ribs 51, 54 are also provided

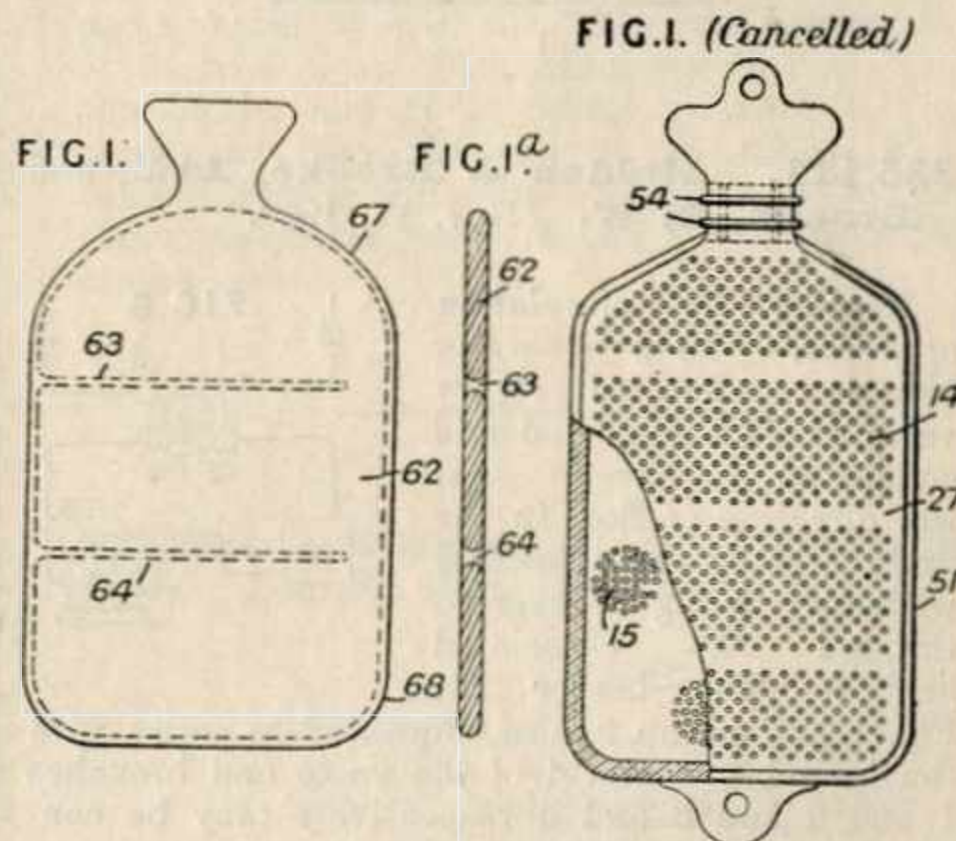

to prevent direct contact with the surface of the bottle. This subject-matter does not appear in the Specification as accepted.

**334,884. Garland, J.** June 10, 1929.

*Nonconducting coverings for heat.*—Insulation for chill rooms &c. is formed by applying a mixture of cork, calcined magnesite and magnesium chloride solution and after setting facing it with

a mixture of wood flour, calcined magnesite and magnesium chloride solution. The first coating may consist of 90 parts by volume of cork, 8 parts by volume of calcined magnesite and 2 parts by volume of crystalline magnesium chloride dissolved in water.



**Raylor, W.** Aug. 27, 1929.

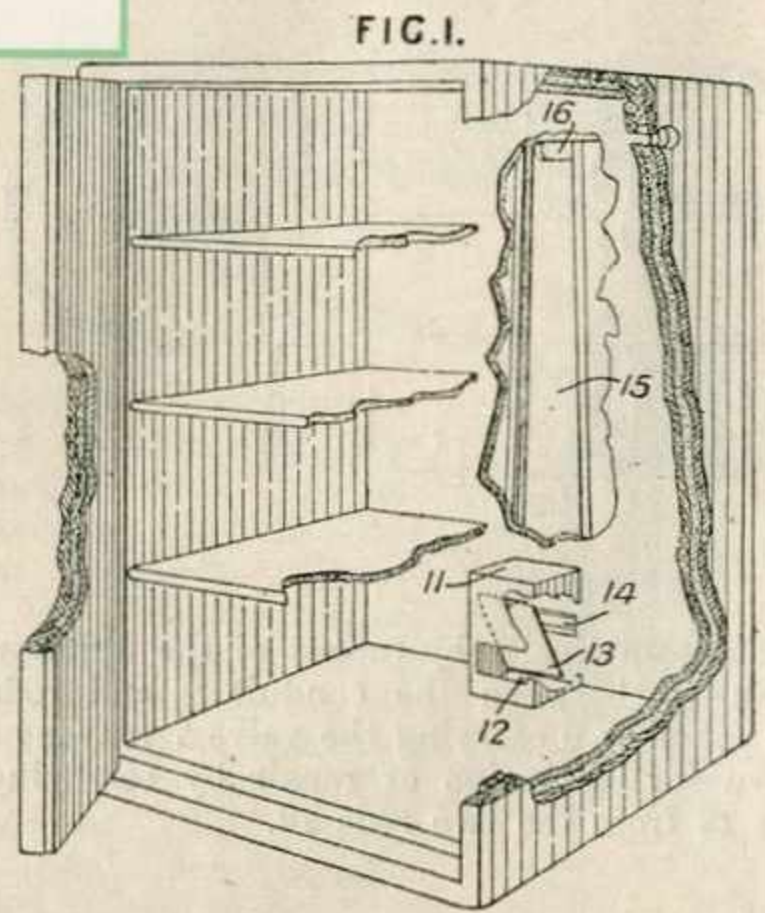

*Nonconducting coverings for heat.* — A refrigerator consists of an inner lining of slate, marble, granite, &c. and a cover of wood or metal, the space between the lining and the cover being packed with cork, slag, wool, &c.

**335,111. Holden & Brooke, Ltd., and Brooke, R. W.** Nov. 12, 1929.

*Heating by circulation of fluids.* — In a hot-water heating system a rotary valve is so constructed and connected in circuit that the direction of flow in the system may be reversed without being reversed through the associated heater. The heater 24, Fig. 6 and pump 25 are connected in series with the branches 2 and 4 of the valve and branches 1 and 2 and 3 and 4 respectively may be con-

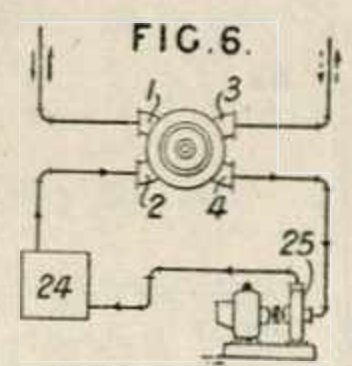

nected together or branches 1 and 4 and 3 and 2, thus reversing the flow in the system connected to branches 1 and 3 and not reversing the flow in the heater. The valve comprises a

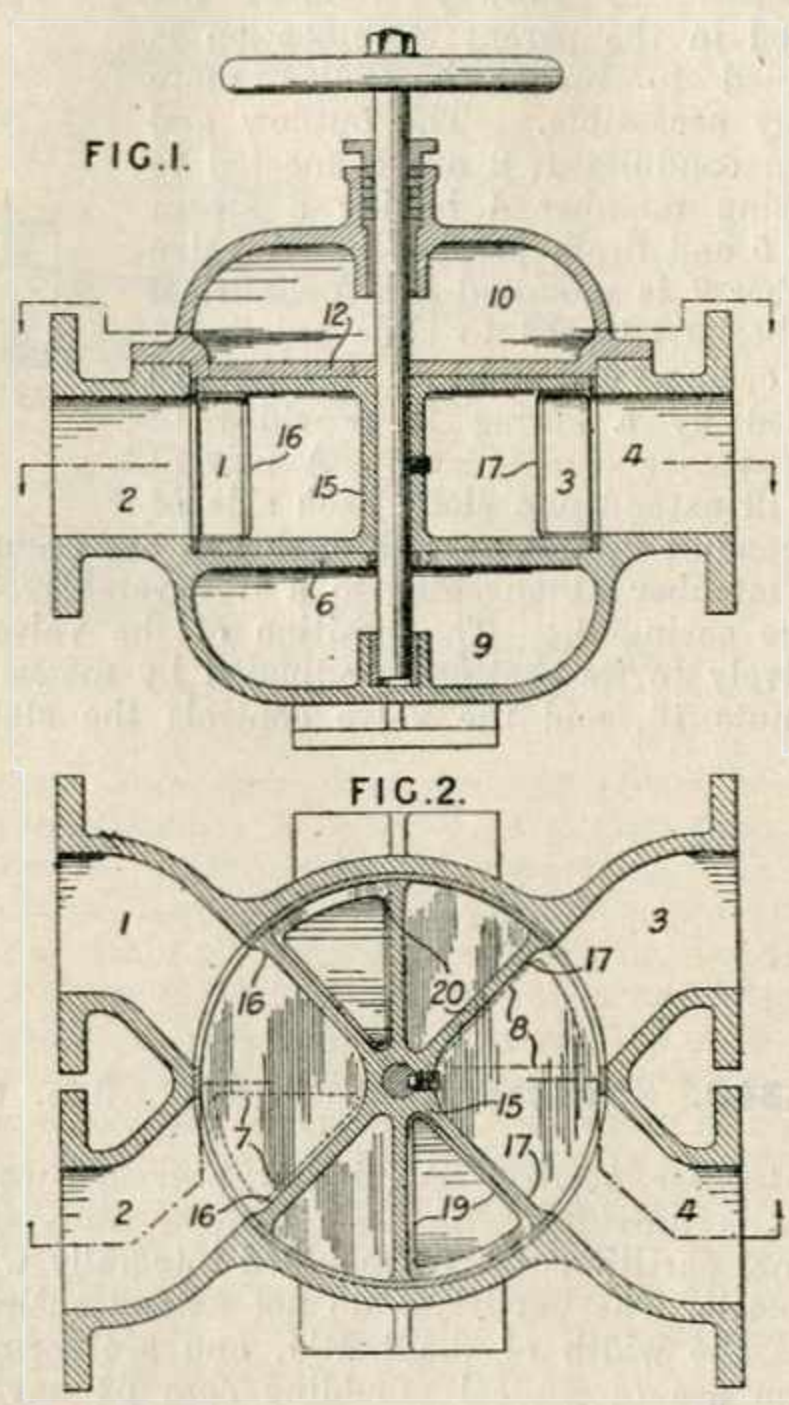

rotary member 15, Figs. 1 and 2, having peripheral and end ports and divided by ported diaphragms 12 and 6 from end chambers 10 and 9. With the valve in the position shown in Fig. 2, peripheral ports 16 and 17 connect branches 1 and 2 and 3 and 4. On turning the valve through 90° ports 16 and 17 move out of connection and ports 19 and 20 in the bottom of member 15 coincide with ports 7 and 8 in diaphragm 6 thus allowing water to flow from branch 2 to branch 3 through chamber 9. In a similar manner water flows from branch 1 to branch 4 through chamber 10. Specification 303,596 is referred to.

**335,267. Ayrton, Saunders, & Co., Ltd., and Twells, F.** June 4, 1929.

*Hot-water bottles and like heating apparatus.* — A hot-water bottle, bed, cushion, pillow, or like hollow article of rubber having a canvas or like foundation is provided with an inner rubber lining of a different composition from the outer rubber facing, and containing about 5 per cent of carbon black, whereby it has a lower capacity for absorbing water. The inner lining may extend up to and over the rim of the filling mouth.

**335,634. Musgrave, J. L., Herring, E., and Crittall & Co., Ltd., R.** April 1, 1930.

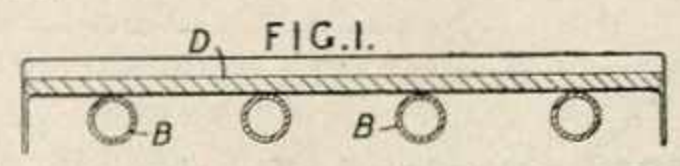

*Radiators.* — The heating or cooling tubes B of a radiator are welded to a hollow metal casing containing a slab D of heat-insulating material. In a modification, the pipes are welded to a flat plate having a backing of heat-insulated material.



**335,730. Sehar, F.** Sept. 20, 1929.  
*Drawings to Specification.*

*Thermostats.*—A heat-sensitive element for use in egg-boiling apparatus consists of a container filled with naphthalene or other solid which expands on liquefaction.

bottle at 12. Slots 6 are formed in the webs to receive a flexible strap 7 which passes around the funnel, and the free ends of the strap are connected by coupling pieces 9, 10 to form a loop

**335,747. Kemper, R. T.** March 27, 1929,  
*[Convention date].*

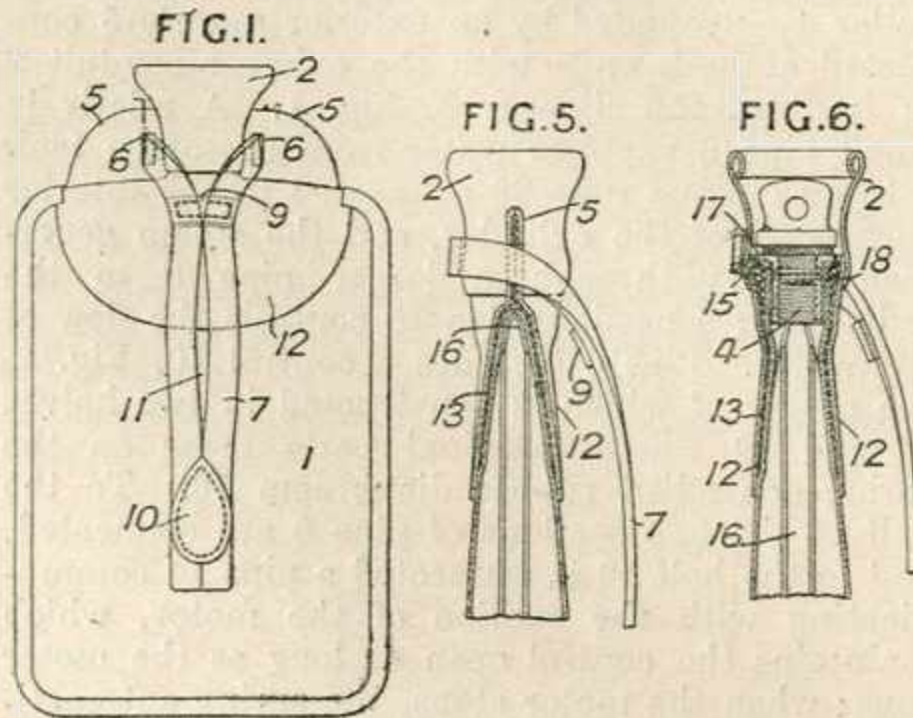

11 through which the fingers may be inserted. During filling of the bottle, the handle may be held away from it to avoid scalding by the issuing steam, and when not in use the free end 7 may lie flat against the body so that the whole may be enclosed in the usual cover. The upper edges of the bottle are reinforced by a strip 16, Figs. 5, 6, and after the metal neck 4 is inserted and cemented, a canvas band 17 is wrapped round and secured by wire 18. The two halves 12, 13 of the web 5 are then cemented to the sides of the bottle, and their upper portions cemented together. The portions 15 of the webs are cemented over the canvas 17, and the funnel 2 cemented to the parts 15 and to the inner edges of the webs.

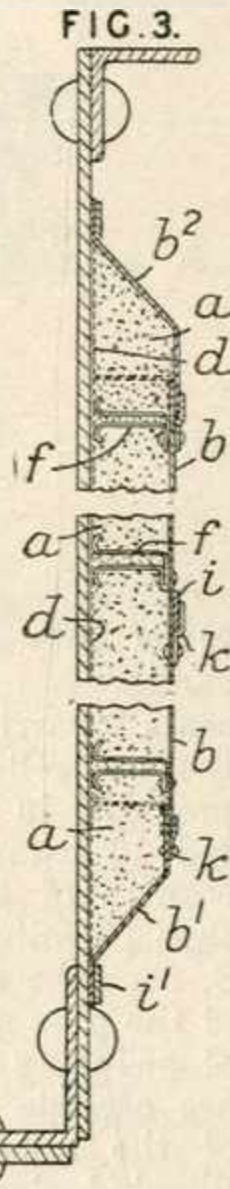
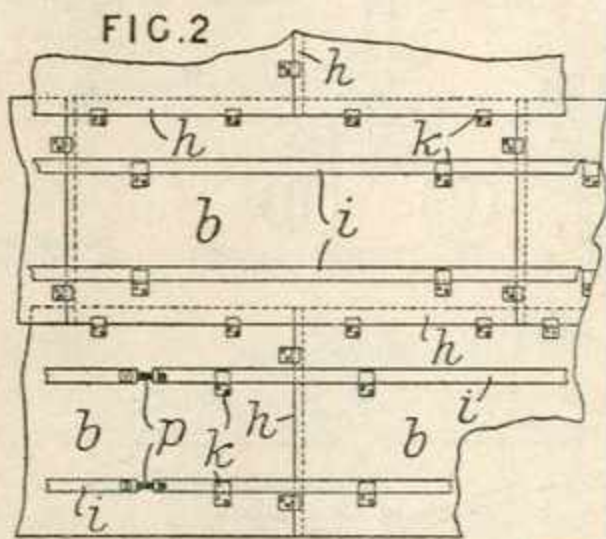

*Nonconducting coverings for heat.*—Insulating material *a* is secured between a plate *b* and wire net *d* which is supported by ties *f*. The plates *b* are adapted to overlap at *h* so that adjacent units are capable of relative movement. The plates may be of metal, asbestos board, asbestos fabric, wood, fibre, or other material having sufficient stiffness. The lowest plates *b*<sup>1</sup> are secured to a receptacle to be insulated by a band *i*<sup>1</sup> and carry small clips *k* adapted to hold the plate *b* of the adjacent unit. Similar clips *k* are provided to receive bands *i*, which may be tightened by tension members *p*. The uppermost plates *b*<sup>2</sup> are similar to the lower plates *b*<sup>1</sup>. The overlapping of the plates of adjacent units permits expansion due to heat.

**335,842. Schmid, O., and Heitzmann, W.** Dec. 31, 1928, *[Convention date].*

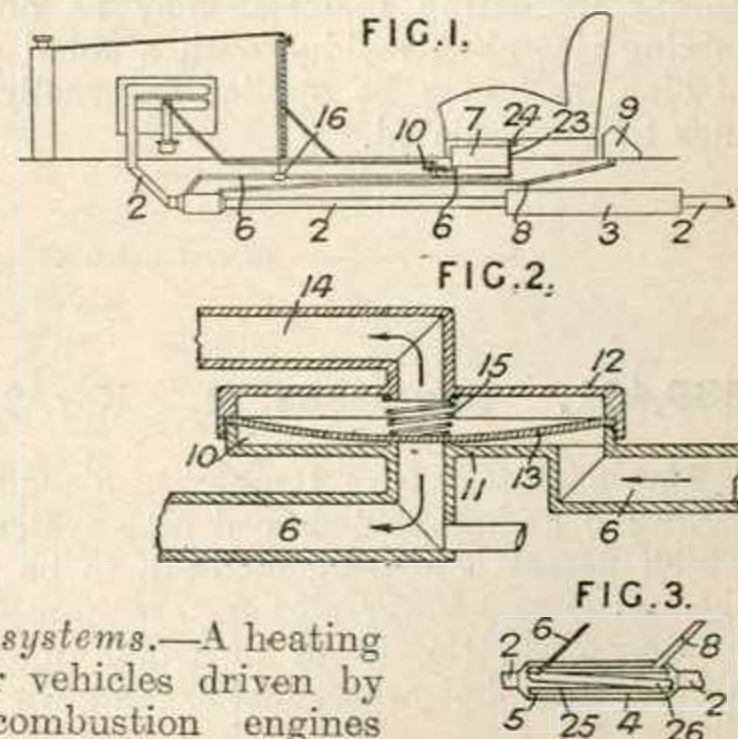

*Heating systems.*—A heating device for vehicles driven by internal combustion engines comprising a steam generator heated by the exhaust and radiators in the interior of the vehicle is characterized by the fact that a control for feeding the

**335,833. Schutze & Co., Ltd., F., and Schutze, F.** Dec. 11, 1929.

*Hot-water bottles.*—An indiarubber hot-water bottle is provided with a flexible handle adapted to lie flat against the bottle when not in use and to be held away from the bottle during filling. The bottle 1 is provided with the usual filling funnel 2, and webs 5 of two thicknesses of canvas-reinforced rubber are cemented to the sides of the funnel, and over the shoulders of the





water in drops is inserted into the supply conduit to the generator, as well as means automatically opened by the suction of the motor, and closed when the motor stops. The steam generator, Fig. 3, consists of a hollow cylindrical boiler 4 surrounded by an exterior mantle 5 connected at both ends with the exhaust conduit 2 in front of the silencer 3, Fig. 1. A relatively small pipe 6 supplies water from a storage tank 7 to an oblique tube 26 connected to the interior surface 25 of the cylinder, and the steam generated passes through a larger pipe 8 to the radiator 9; a needle valve 16 controls the flow of the water. Pipe 6 includes a control 10, Fig. 2, the casing of which is constructed in two halves 11 and 12 whose marginal parts press on the spring controlled rubber diaphragm 13. To the half 11 the two sections of pipe 6 are connected, and to the half 12 is connected a pipe 14 communicating with the suction of the motor, which maintains the control open as long as the motor runs; when the motor stops, the spring automatically closes pipe 6. An air pipe 23 rising above the water level of tank 7 and provided with a check valve 24 permits the section of pipe 6 in front of the control to empty.

4 are mounted in end pieces 7 forming seats for the corners of the pipe system, and the length of the bend is so adjusted that it is not released at any temperature which may occur. A plate

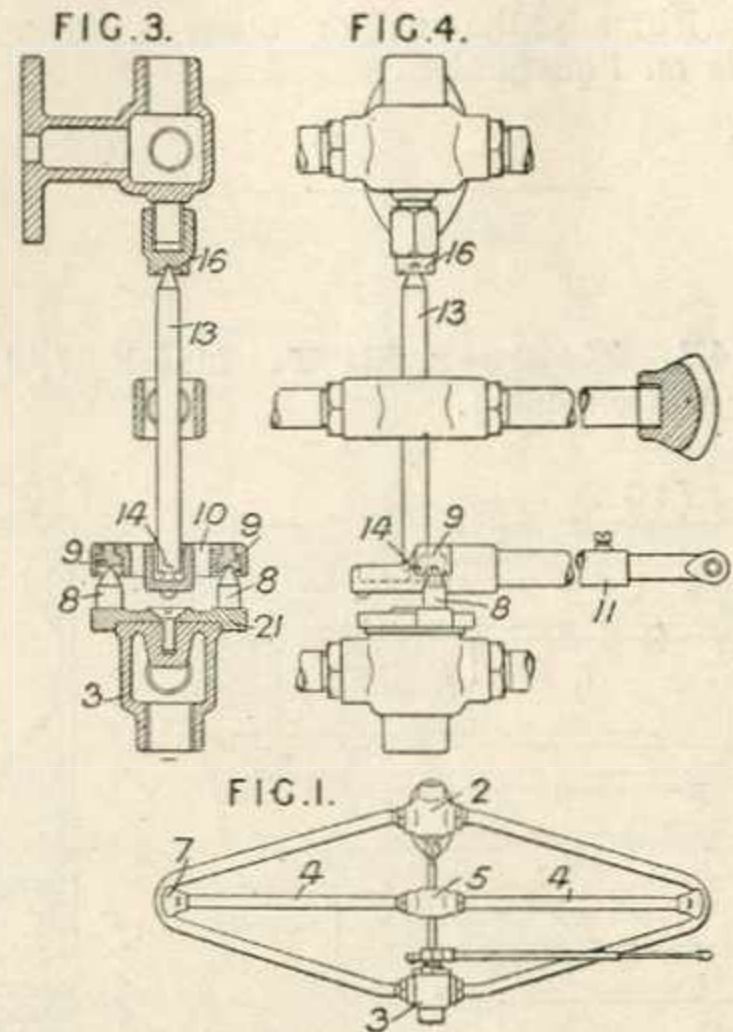

**336,440. Cases, M.** Oct. 24, 1928, [Convention date].

*Nonconducting coverings for heat and sound* are formed by the use of a substantial proportion of the residue of combustion of rice chaff. An insulating felt may comprise asbestos 5—10 per cent, silicate wool 20—40 per cent, product of combustion of rice chaff 50—75 per cent, with preferably traces of starch, fused silicates or the like as binding agents. In another example, a mixture of 10—40 per cent clay, 2 per cent granulated cork, and 88—58 per cent rice chaff residue yields a light porous material, from which the cork may be removed by combustion. Non-porous insulating material may be obtained by mixing rice chaff residue with a small proportion of clay, and may be applied externally to buildings to be insulated.

21 is rotatably mounted in the socket 3 and carries two conical studs 8 forming fulcra for seats 9 carried by a part 10 rigidly connected to the controlling lever 11. Another seat 14 is provided in the lower end of a freely mounted rod 13 extending between the upper and lower corners of the rhomboid. Temperature change thus permits the lever 11 to pivot about the axis 8, 8 as the rod 13 moves vertically on expansion of the pipe system. The lever 11 is also capable of swinging laterally since the members 10, 21 are capable of rotation together about the axis of the rod 13. The seats 9, 14, 16 are all directed downwards to avoid accumulation of dust about the pivots.

**336,481. Carlstedt, R.** Nov. 25, 1929.

*Thermostats.*—In a temperature regulator consisting of a rhomboid-shaped pipe system through which passes a heating medium to be regulated, the upper and lower corners are formed by pipe sockets 2, 3, the lower of which may be connected to a hot water boiler and the upper to the riser pipe. The other two corners are connected by a pressure bond 4 consisting of two rods or pipes connected by a member 5 having a central opening. The outer ends of the pipes

**336,576. Dunlop Rubber Co., Ltd., and Bulger, J. G.** July 13, 1929.

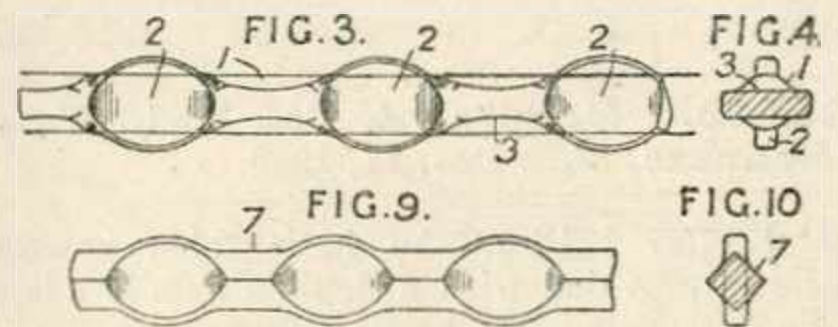

*Hot-water bottles.*—A wire reinforcement for tyre beads, hot-water bottles, &c. is formed with an undulatory or like surface by indenting or other means which destroy the original uni-

formity of the wire. Figs. 3 and 4 show one form produced from wire of round-section 1 by alternating diametrically-opposed indentations 2, 3. Figs. 9 and 10 show a modification produced from square-section wire 7.

The coating may be produced by (1) cementing thin sheets of micro-porous rubber produced according to Specification 240,430, [Class 70, Indiarubber &c.] to the surface; (2) coating by spraying or dipping with a rubber gel containing a suitable amount of sulphur, and vulcanizing; (3) coating by spraying or dipping with rubber latex or solution containing sulphur, causing the coating to gel by means of a coagulant and vulcanizing; (4) depositing a porous coating of rubber and sulphur by electrical methods and vulcanizing; (5) applying a composition of powdered micro-porous rubber and an adhesive; or (6) spraying or otherwise applying powdered micro-porous rubber to a surface rendered adhesive.

**337,222. Beckmann, H.** Nov. 14, 1929.

*Nonconducting coverings for heat.* — A thin layer of rubber having exceedingly fine pores is applied as a coating for heat and cold insulation.

**337,302. Taglietti, U., and Tasso, A.** Jan. 29, 1929, [Convention date].

*Heating by circulation of fluids.* — In a condensate collecting apparatus communicating with a number of groups of steam heaters each group working at different pressures on the closed cycle system and connected to independent collectors, the latter release their excess steam or discharge excess condensate to a heat accumulator. The collector of the low pressure group works as a continuous discharger of the accumulator. The steam heaters 1-1 - - 3-3 working at high, medium and low pressures discharge their excess steam and condensate to the collectors B<sup>1</sup> - - B<sup>2</sup>, respectively, from which the liquid is pumped to the boiler by the pumping apparatus 30 - - 32. Excess condensate passes from B<sup>1</sup> and B<sup>2</sup> to the accumulator P through pipes 18, 19 and excess steam through safety valves VS<sup>1</sup>, VS<sup>2</sup> to the same reservoir. The low pressure collector B<sup>3</sup> and the accumulator are at the same pressure, condensate discharging from the latter to the former, which also receives excess condensate and steam from the low pressure group 3-3. The pressure in the latter is kept beneath a suitable limit by adjusting the pressure in the accumulator. This may be effected by automatic injection of cold water under pressure into the accumulator, the supply being controlled by a valve actuated by the pressure existing in the accumulator; or by combining with the accumulator a tubular heat exchanger having cold water circulating through the tubes; or the accumulator may work as an intermittent steam generator or as a continuous generator in a secondary steam heating plant. Specification 295,104, [Class 102 (i), Pumps &c.], is referred to.

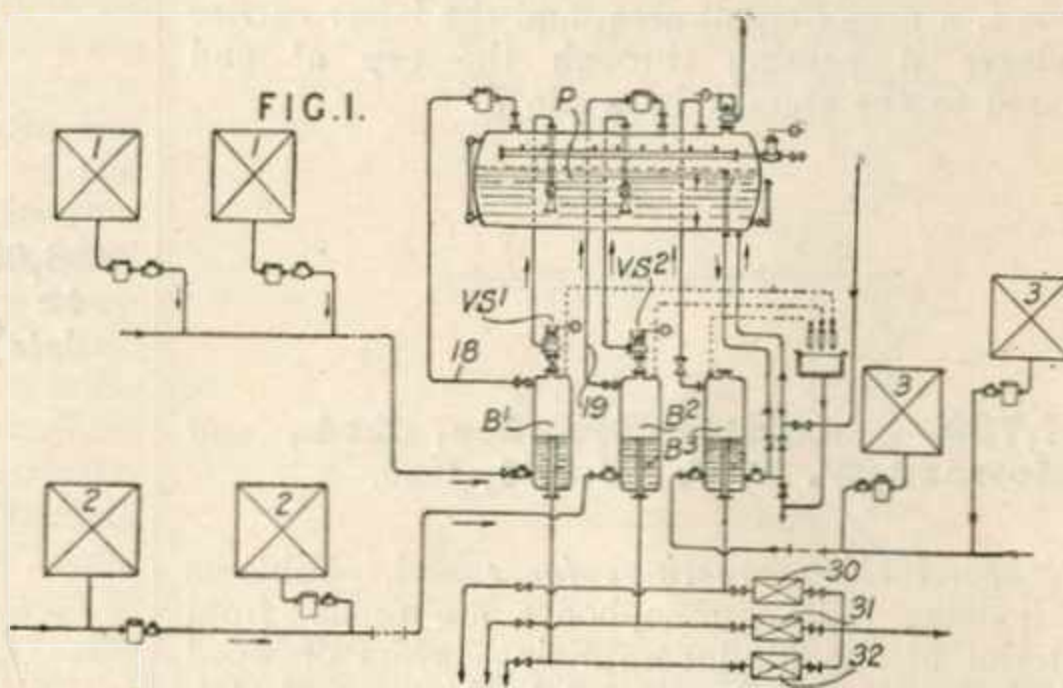

**337,332. Weber, J. C.** March 5, 1930.

*Nonconducting coverings for heat.* — Heat insulation for ships' sides 1 comprises insulating material 2 held by a sheet of stronger material 5 bolted to the sides, and nuts 7 on the bolts 4 lie within with caps 6 extending with play into openings in the sheet 5. The annular flange of each cap 6 presses on the asbestos cement sheet 5. The caps 6 are filled with hardening material 8. Magnesia blocks covered by a metal fabric over which lies asbestos cement mortar may be used as insulating material, or loose asbestos and cork covered by sheets of wood or asbestos cement.

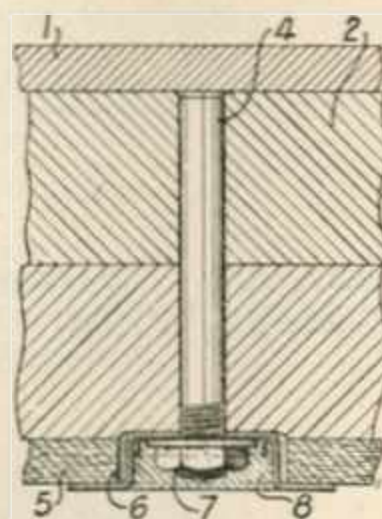



ULTIMHEAT<sup>®</sup>  
VIRTUAL MUSEUM

337,425. **Hammond, C. F., and Shackleton, W.** July 31, 1929.

*Thermostats.*—In a thermostatic control device for hot-water and oil heat storage systems, the effect of varying pressure head on the heat-sensitive bellows *i* containing an expansible fluid is counteracted by providing on the same stem *k* a similar bellows *m* tending to move the stem in the opposite direction as the result of pressure. The inside of the bellows *m* is open to the air at *p*, and the control valve *h* for the passage of liquid from *f* to *g* is carried by the stem *k*. The two bellows heads *l, n* are of equal area, and the latter carries a sleeve *n* passing through the cap *a<sup>2</sup>* and secured to the stem *k* by a pin *o*.

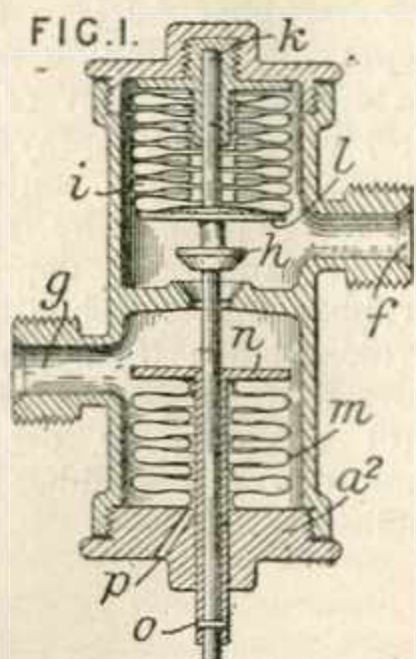

337,739. **Kolster-Brandes, Ltd., and Howard, F. S. J.** July 1, 1929.

*Nonconducting coverings for sound.*—Cabinets for housing radio gramophones are made from material of the kind comprising layers of wood united to cork or other sound-deadening material, for example, a sheet of wood with an attached layer of cork of one half the thickness of the wood.

337,803. **Pilkington Bros., Ltd., and Hogg, P. M.** Aug. 2, 1929.

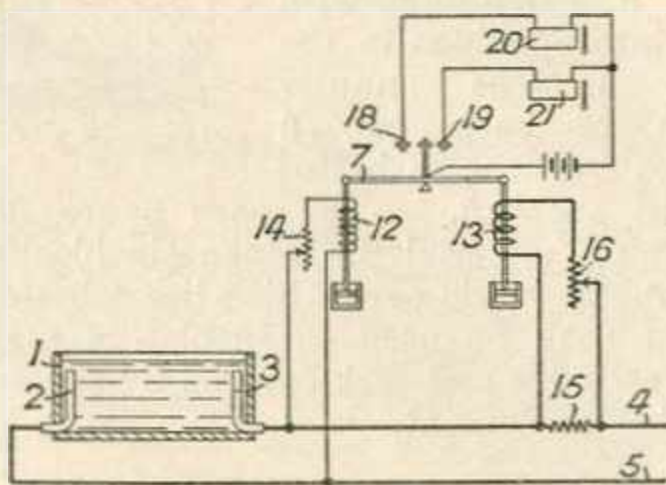

*Thermostats.*—The temperature of a body which is heated in an electric or other furnace is regulated by passing a current, which may be

the heating current, through the body, and utilizing the variations in conductivity due to temperature variations, to control the heating means. In the application to a glass kiln 1 heated by the passage of current between electrodes 2, 3, connected through a resistance 15 to supply mains 4, 5, a solenoid 12 is connected across the electrodes 2, 3 through a variable resistance 16. A predetermined fraction of the voltage and of the current can thus be utilized in the solenoids 12, 13 respectively, and at a predetermined average temperature of the glass the beam 7 will remain balanced. Any variation in the conductivity of the glass will result in the beam 7 becoming unbalanced, and contact will be made at 18 or 19, relay 20 or 21 will be energized, and a voltage regulator operated to rectify the voltage across the electrodes in the kiln. If the heating is not electrical, current is passed through the charge merely to measure the average conductivity and operate the regulating device.

338,097. **Soc. of Chemical Industry in Basle.** April 29, 1929, [Convention date].

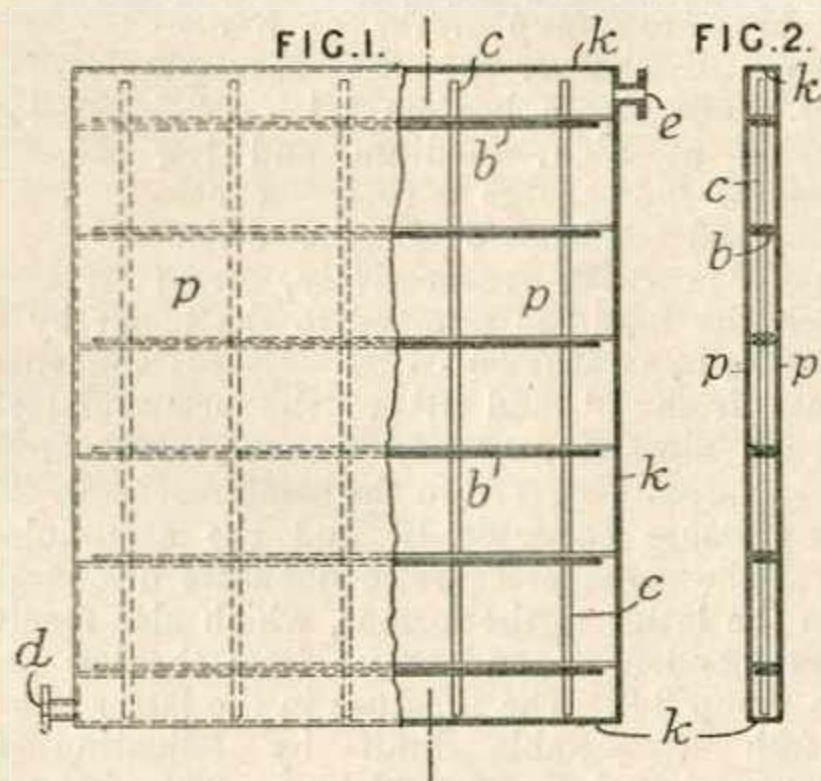

*Radiators for heating buildings.*—A radiator has the form of a hollow plate, the heating surfaces of which consist of plates *p* connected by bars *c* inserted through perforations in inwardly projecting ribs *b* carried by the plates. Strips *k* are welded round the edges of the plates to complete the chamber and an inlet *d* and outlet *e* for the heating fluid are provided.

**338,161. Pfeiffer, W., and Reiss, K.**  
April 18, 1929, [Convention date].

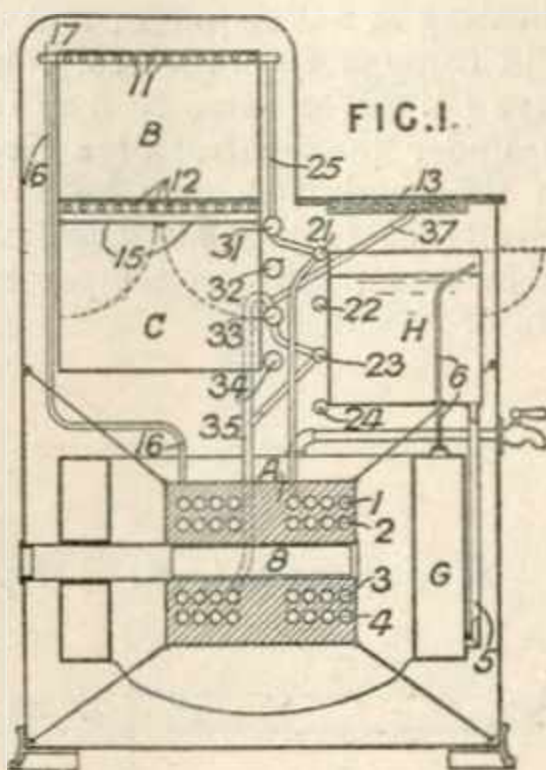

*Heat-storing apparatus.*—In heating-apparatus in which heat is transmitted from an accumulating element to the place of consumption by a liquid medium contained in a closed circuit, the heating effect is regulated by alteration of the quantity of the contained liquid. The invention is described as applied to a cooking-stove, in which pipe coils 1 - - 4 are embedded in a heat-accumulating block A containing an electric heater 8. Each pipe coil forms part of an independent heating circuit, two of which include respectively two series of oven-heating pipes 11, 12, and the other two comprise tubes heating two hot-plates one of which is shown at 13. Water evaporated in the coil 1 passes as steam up the pipe 16 and thence to a header pipe 17 and through parallel heating-tubes 11, at the top of an upper oven B, the condensed water flowing through a pipe 25 to a condensate collector 31, whence it passes under control of a valve 21 back to the coil 1. The pipes 12 form part of a similar circuit including a condensate collector 32, valve 22 and the coil 2; they form a bottom heating means for the oven B and a top heating means for the lower oven C, which can, however, be shielded from them by hinged flaps 15. The hot-plate 13 is heated from the coil 3 through pipes 35, 37, which serve both as flow and return pipes, the condensate passing into a collector 33 and returning under control of a valve 23, to the pipe 35 and coil 3. A similar system, including a condensate collector 34 and valve 24 is provided for heating the other hot-plate. To enable the quantity of water in each system to be varied, or to withdraw it altogether, to put a system out of action, the valves 21 - - 24 each comprise two controlling members, one of which regulates the passage of the liquid round the heating circuit and the other connects the circuit to a pipe (not shown) leading to the bottom of an annular hot-water container G which surrounds the heat-accumulator A, or to a separate container if distilled water or other liquid is employed. The water is introduced into the system when the latter is cold, being drawn in owing to the vacuum which then exists. Water is heated in

the tank G by radiation from the heat-accumulator A and in an auxiliary tank H by radiation from the hot-plates and parts of the heating-circuits adjacent it. The tanks are connected by a pipe 5 and a vent pipe 6 is provided. In cases where distilled water or other liquid is employed in the heating-circuits the hot liquid withdrawn from them passes through a collector in the hot-water tank, gives up its heat to the latter and passes to a separate container. Where ordinary water is employed it is delivered when withdrawn into the tank G.

**338,349. Kuhn, J.** Nov. 6, 1929.

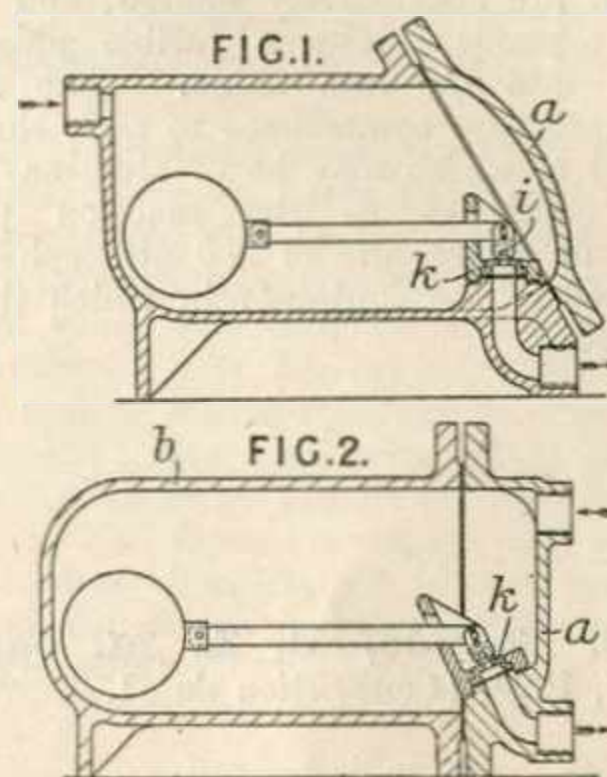

*Steam traps.* — In a steam trap of the kind described in Specification 277,842, the seating *k*, Fig. 1, for a float-operated slide valve *i* is arranged horizontally, and the cover *a* is arranged obliquely to facilitate access to the seating. In a modification, Fig. 2, the seating *k* is oblique and is arranged in the cover *a*, the casing *b* being simple and easily removed.

**338,403. Rudin, E., and Kollbrunner, H.** Dec. 13, 1928, [Convention date].

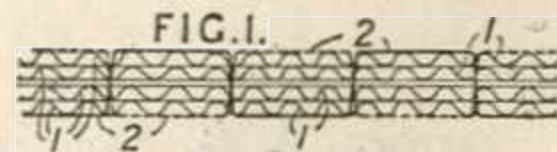

*Nonconducting coverings for heat and sound.* —Waterproof plates or sheets for building purposes are made by superposing pieces of corrugated cardboard 1 with the corrugations of adjacent layers at right angles, binding the layers together without adhesives by sewing with thread or wire 2, or by wire staples or wooden pegs, drying at 60° to 70° C., impregnating the material with a hot liquid waterproofing medium such as coal tar pitch, and shaping it whilst still warm between iron plates.



338,468. Blümner, E. March 11, 1930.

*Heating by chemical action.* — In an aluminothermal process, very high temperatures are obtained by employing one or both components in molten state. Iron oxide is placed in an annular vessel *b* and aluminium in a vessel *c*. An outer vessel *a* contains an aluminothermal mixture which may be ignited electrically or by a fuse *i*. The vessel *a* is surrounded by insulating material and is placed in a closed pressure-resisting container which is placed in a vessel of water. When the mixture *h* is ignited, the iron oxide *f* and aluminium *d* are successively melted, and the aluminium expands, melts a fusible plug *g*, and overflows into the iron oxide. The resulting high temperature commences to melt the wall of the vessel *c*, which may be of alumina, and the melting continues as the reaction proceeds. Nitrogen at a pressure of 200 atmospheres may be supplied to the container in which the vessel *a* is placed.

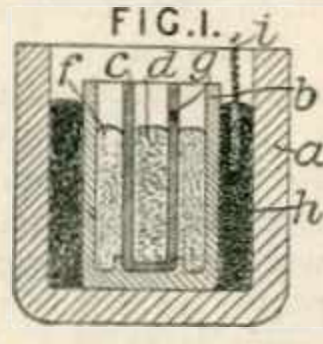

circulation pipes of a circulatory fluid heating system allow a restricted flow of heating fluid through one of the conduits  $A^1$  when the normal degree of heating is not required, and the flow of heating fluid through the other conduit  $A$  is cut off by a valve  $B^1$ . The valve  $B^1$  may be operated electrically under the control of a clock. The valve  $B$  in the conduit  $A$  may be so controlled thermostatically as to regulate the fluid flow to maintain a desired minimum temperature in the heated room or chamber.

338,880. Negromanti, A. May 18, 1929.

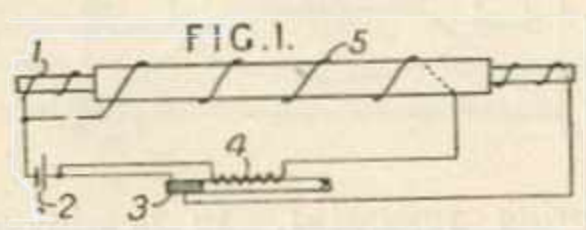

*Thermostats.*—An electrically-heated fabric is provided with means by which any extensive or local overheating causes a break in the heating circuit. The heating resistance 1 is arranged in a circuit including a battery 2 and thermal switch 3, and a control wire 5, the resistance of which increases with temperature, arranged close to the wire 1 over its whole length and insulated from it. The circuit of the wire 5 includes the battery 2 and a heating resistance 4 adjacent to the thermal switch 3. The switch 3 is open when cold, but by the passage of a heating current in the resistance 4 the switch closes the circuit of the main heater 1. Any overheating causes an increase in the resistance of the control wire 5 so that the current in the resistance 4 is no longer sufficient to keep the switch 3 closed. In a modification, Fig. 2, not shown, the thermal switch is closed when cold and its circuit includes two wires with free ends which follow the fabric-heating wire but are insulated from it. The two wires are covered by a metallic oxide which when cold is a bad conductor but when overheating occurs in the fabric becomes a good conductor and allow current to pass through the heater of the thermal switch which is thereby opened and the main circuit broken. In another modification, Fig. 3, not shown, the controlling circuit and the heating circuit are arranged as the four arms of a Wheatstone bridge. When the temperature equilibrium of the bridge is disturbed by overheating, a current flows in the diagonal of the bridge and operates either a thermal switch of an electromagnetic relay. The length of the arms of the bridge may be changed by a slider to enable different voltages to be used in the heating circuit, and the temperature limits of the device may be varied by varying the ratio of the arms of the bridge.

338,685. Lande, B. L. M. van der. Sept. 7, 1929, [Convention date].

*Radiators.* — A radiator consists of a number of tubes 1 directly secured in headers 2 by casting the latter as a whole in one process round the ends of the tubes. The tubes may have tapered ends 3 so that by using a straight core 6 the end of the tube may be entirely surrounded with the cast metal. The tubes may have screw threads 5 at their ends.

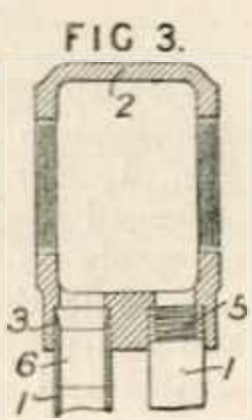

Reference has been directed by the Comptroller to Specification 353,626, [Group XXII].

338,857. Brown, A. G. Aug. 22, 1929.

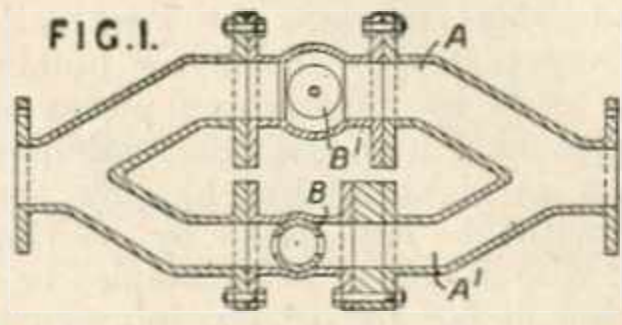

*Heating by circulation of fluids.*—The conduits  $A, A^1$  connected in parallel and arranged in the

**338,960. Coca-Cola Co.,** (Assignees of Staton, J. C.). Jan. 9, 1929, [Convention date].

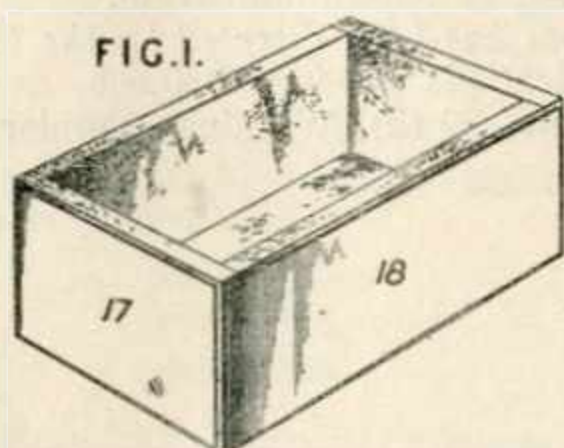

*Nonconducting coverings for heat.* — A refrigerator box is formed of slabs of cellular material known as "Clotex" and dipped into a bath of asphalt. Specifications 10746/00, [Class 29, Cooling &c.], and 306,011 are referred to.

**339,067. Dyckerhoff, E.** Oct. 30, 1929.

*Nonconducting coverings for heat.*—Peat and like material is treated to render it substantially fireproof and non-smouldering by boiling it and treating with fireproofing chemical solutions. Crude peat or marshy turf is charged into a container which is closed and heated under pressure to 100° C. or more. Before or during boiling, dilute phosphoric acid or other fireproofing chemical is added, and the peat is finally pressed, dried, and treated in any known manner for the manufacture of peat meal or shaped or pressed articles. The proportion of water in the crude material is preferably reduced before treatment, e.g., by adding a proportion of dry peat obtained in this process, in order that the fireproofing solution subsequently removed shall not be too dilute for use again.

**339,303. Industrial Process Corporation.** Nov. 26, 1928, [Convention date].

*Heating by circulation of fluids.* — In raising the temperature of containers by the use of a heating medium consisting of a condensible gas and an inert gas such as steam and carbon dioxide, the amount of condensate formed is taken into account in calculating the pressure of the inert gas to give the required results. A working example is given in the Specification.

Reference has been directed by the Comptroller to Specification 305,577.

**339,463. Firestone Tyre & Rubber Co., Ltd.,** (Firestone Tire & Rubber Co.). Nov. 21, 1929.

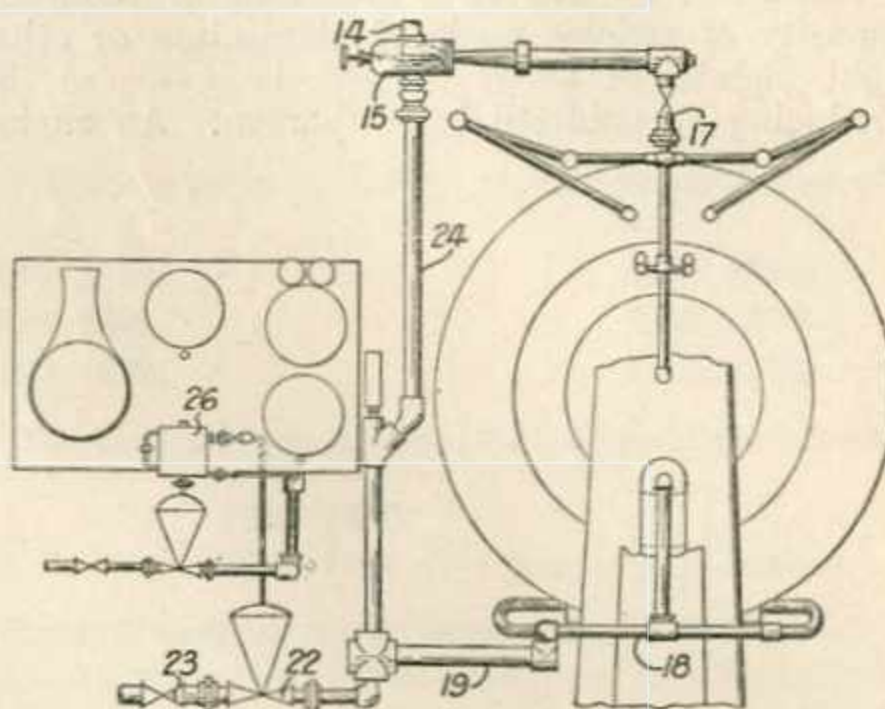

*Heating by circulation of fluids.* — Steam or other vapour is injected into the jacket of a vulcanizer and exhausted under thermostatic control so as to feed back the whole or part of the vapour for reinjection into the jacket. Steam is supplied through pipe 14, injector 15 and check valve 17, and is exhausted through pipes 18, 19, and valves 22, 23. The valve 22 is controlled by a thermostat 26 to permit all the condensate and some of the steam to escape and so maintain a constant temperature in the vulcanizer. The remaining steam is returned through pipe 24 to the injector.

**339,512. General Electric Co., Ltd., Crampton, W. J., and Pillans, J. P. S.** Dec. 23, 1929.

*Heat-storing apparatus.*

— In a heating-apparatus such as an electric cooking stove in which stored heat is carried by a fluid, e.g., oil, flowing to heat-utilizing means, the operation of a valve for controlling the circulation of the fluid also controls a pump which circulates the fluid. A tank 1 contains oil which is heated by an electric heater 6. Flow and return pipes 8, 9 are provided, and between them are arranged in parallel a pipe coil 12 surrounding an oven 2, and two hot plates 3, 4. The heated oil is allowed to circulate to these through valves 13, 15, 18, any one of which when turned to the "on" position also closes an electric switch controlling a motor driven pump 21 which circulates the oil.

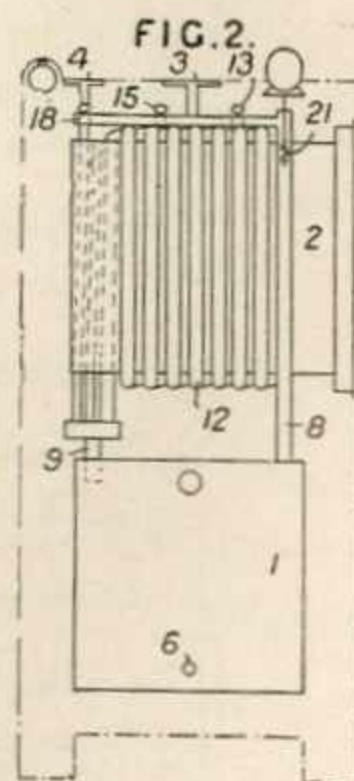



**Triggs, W. W.,** (*Vereinigte Aluminium-Werke Akt.-Ges.*). Oct. 11, 1929.

*Radiators.* — The heat absorbing or radiating capacity of articles made of aluminium or other light metals, or alloys thereof, is increased by producing an oxidized layer thereon. An engine

cylinder made of a magnesium-aluminium alloy is coated with a layer of pure aluminium which is then subjected to treatment for the production of a coating of aluminium oxide.

*Reference has been directed by the Comptroller to Specifications 200,944, 260,536, and 287,194, [all in Class 82 (ii), Washing granular &c.].*

## APPENDIX

**250,820. Marks, E. C. R.,** (*Electro-Thermal Co.*). Sept. 14, 1925. *Drawings to Specification.*

*Dilators; rectal appliances; heating-appliances.* — A hollow surgical dilator is filled with crystals or a saturated solution of sodium hypophosphite. The dilator is immersed in boiling water and

allowed to cool. When required for use the liquid is caused to crystallize and give out heat by introducing a crystal of sodium hyposulphite or a splinter &c. Instead of using the hyposulphite the dilator may be filled with water and a soluble capsule containing sodium or potassium introduced.



# ILLUSTRATED ABRIDGMENTS OF SPECIFICATIONS

Published in three continuous series as follows :—

Series (A.)—Classified in 146 volumes for each of the following periods dealing with all published specifications of the years 1855 to 1908 :—

1855-1866.	1884-1888.	1897-1900.
1867-1876.	1889-1892.	1901-1904.
1877-1883.	1893-1896.	1905-1908.

Series (B.)—Classified in 271 volumes for each of the following periods dealing with all published specifications of the years 1909 to 1930 :—

1909-1915.	1921-1925.
1916-1920.	1926-1930 ( <i>in course of publication</i> ).

Series (C.)—Arranged in 40 Groups (one volume per Group), each Group volume corresponding to one or more of the Class volumes in Series (B.) and (A.) and commencing with the Specifications published in 1931. Each set of 40 Groups comprises the Abridgments of 20,000 Specifications, and sets dealing with the following Specifications are now available :—

340,001-360,000.	360,001-380,000.	380,001-400,000.
------------------	------------------	------------------

A further set, dealing with Specifications 400,001-420,000 is now being issued, week by week, in sheet form.

Price per volume ... .. 2s. 0d. (*postage abroad extra*).

Volumes now in course of publication but not yet completed, can be obtained, sheet by sheet (16 pages) as printed, on payment in advance of a subscription for each volume of 5s. (*inland*), or 7s 6d. (*abroad*). The subscription for a complete set of advance sheets for the 40 Groups is £4 (*inland*), £4 10s. (*abroad*).

List of Classes—Series (A) (1855-1908).	Corresponding Classes—Series (B) (1909-1930).	Corresponding Group Volume —Series (C) (1931 onwards).
1, ACIDS, ALKALIES, OXIDES, AND SALTS, IN-ORGANIC.	1 (i), Chemical processes and apparatus. (1909-15 <i>out of print</i> .) 1 (ii), Inorganic compounds other than metallic oxides, hydrates, oxyacids, and salts, ( <i>including Alkali manufacture and Cyanogen compounds</i> ). 1 (iii), Oxides, hydrates, oxyacids, and salts, Metallic, ( <i>other than Alkali manufacture and Cyanogen compounds</i> ).	III.
2, ACIDS AND SALTS, ORGANIC, AND OTHER CARBON COMPOUNDS, ( <i>including Dyes</i> ).	2 (i), Acetylene ... .. 2 (ii), Cellulose, Non-fibrous, and cellulose derivatives, ( <i>including Artificial filaments, sheets, and the like containing same</i> ). (1909-15 <i>out of print</i> .) 2 (iii), Dyes and hydrocarbons and heterocyclic compounds and their substitution derivatives.	IV.
3, ADVERTISING AND DISPLAYING ... ..	3 (i), Advertising and displaying apparatus, Moving and changing. 3 (ii), Advertising and displaying other than by moving and changing apparatus.	XVIII.
4, AERONAUTICS. (1905-8 <i>out of print</i> ) ... ..	4, Aeronautics ... ..	XXXIII.
5, AGRICULTURAL APPLIANCES, FARMYARD AND LIKE, ( <i>including the housing, feeding, and treatment of animals</i> ).	5 (i), Farmyard and like appliances, ( <i>other than Housing and feeding animals</i> ). 5 (ii), Housing and feeding animals, ( <i>other than Chaff and vegetable cutters</i> ).	I.
6, AGRICULTURAL APPLIANCES FOR THE TREATMENT OF LAND AND CROPS, ( <i>including Gardening appliances</i> ).	6 (i), Cultivating implements and systems ... .. 6 (ii), Gardening and like appliances, ( <i>including Miscellaneous agricultural appliances</i> ). 6 (iii), Harvesting-appliances ... ..	L.
7, AIR AND GAS ENGINES. (1889-1892 1897-1908 <i>out of print</i> ).	7 (i), Combustion-product and hot-air engines. (1909-15 <i>out of print</i> .) 7 (ii), Internal-combustion engines, Arrangement and disposition of parts of, ( <i>including Construction of parts peculiar to internal-combustion engines</i> ). 7 (iii), Internal-combustion engines, Carburetting-apparatus, vaporizers, and heaters for. 7 (iv), Internal-combustion engines, Igniting in ... .. 7 (v), Internal-combustion engines, Starting, stopping, and reversing. 7 (vi), Internal-combustion engines, Valves and valve gear for, ( <i>including Other means and methods for regulating and controlling internal-combustion engines</i> ).	XXVII.
8, AIR AND GASES, COMPRESSING, EXHAUSTING, MOVING AND OTHERWISE TREATING.	8 (i), Air and gases, Compressing, exhausting, and moving, ( <i>including Bellows and Vacuum and like dusting and cleaning apparatus</i> ). (1909-15 <i>out of print</i> .) 8 (ii), Air and gases, Treating otherwise than by compressing, exhausting, and moving.	XXVIII.





ULTIMHEAT®  
VIRTUAL MUSEUM

List of Classes—Series (A) (1855-1908).	Corresponding Classes—Series (B) (1909-1930).	Corresponding Group Volume —Series (C) (1931 onwards).
9, AMMUNITION, TORPEDOES, EXPLOSIVES, AND PYROTECHNICS.	{ 9 (i), Ammunition and ammunition receptacles. (1909-15 out of print.)	XXI.
10, ANIMAL-POWER ENGINES AND MISCELLANEOUS MOTORS.	{ 9 (ii), Torpedoes, explosives, and pyrotechnics... 10, Animal-power engines and miscellaneous motors ...	XXVI.
11, ARTISTS' INSTRUMENTS AND MATERIALS ...	11, Artists' instruments and materials ...	XV.
12, BEARINGS AND LUBRICATING-APPARATUS ...	{ 12 (i), Bearings and bearing-surfaces ... 12 (ii), Lubricating passages, channels, reservoirs, and baths, and lubricating-cans. 12 (iii), Lubricators and lubricating bearing-surfaces, (other than Lubricating passages, channels, reservoirs, and baths).	XXXIV.
13, BELLS, GONGS, FOGHORNS, SIRENS, AND WHISTLES.	13, Bells, gongs, foghorns, sirens and whistles ...	XXXVIII.
14, BEVERAGES, (excepting Tea, coffee, cocoa, and like beverages).	{ 14 (i), Aerating liquids, and gazogenes, seltzogenes, and siphon bottles. 14 (ii), Beverages, malt products, and organized ferments, (other than Aerating beverages).	VI.
15, BLEACHING, DYEING, AND WASHING TEXTILE MATERIALS, YARNS, FABRICS, AND THE LIKE, (excepting Dyes).	{ 15 (i), Dyeing and otherwise treating textiles, textile materials, and the like with liquids and gases, Apparatus for (including Bleaching and washing, Processes and materials for). 15 (ii), Dyeing, Processes and materials for ...	IV.
16, BOOKS (including Cards and card cases and the like).	16, Books, mercantile forms, and the like ...	XV.
17, BOOTS AND SHOES ...	{ 17 (i), Boots and shoes, Apparatus for making and repairing... 17 (ii), Boots and shoes, Construction of ... 17 (iii), Boots and shoes, Protectors and trees and other accessories for.	VII.
18, BOXES AND CASES, (excepting Trunks, portmanteaux, hand and like travelling bags, baskets, hampers, and other wickerwork).	18, Boxes and cases ...	XVII.
19, BRUSHING AND SWEEPING ...	19, Brushing and sweeping ...	XXIII.
20, BUILDINGS AND STRUCTURES ...	{ 20 (i), Buildings and structures, Kinds or types of ... 20 (ii), Buildings and structures, Miscellaneous accessories and details applicable generally to. 20 (iii), Doors and windows and their accessories ... 20 (iv), Floors, roofs, walls, and ceilings ...	X.
21, CASKS AND BARRELS ...	21, Casks and barrels ...	XVII.
22, CEMENTS AND LIKE COMPOSITIONS ...	22, Cements and like compositions ...	V.
23, CENTRIFUGAL DRYING, SEPARATING, AND MIXING MACHINES AND APPARATUS.	23, Centrifugal machines and apparatus, (other than Centrifugal fans, pumps, and reels).	II.
24, CHAINS, CHAIN CABLES, SHACKLES, AND SWIVELS.	24, Chains, chain cables, shackles, and swivels ...	XXV.
25, CHIMNEYS AND FLUES, (including Ventilating-shaft tops).	25, Chimneys and flues, (including Ventilating-shaft tops).	X.
26, CLOSETS, URINALS, BATHS, LAVATORIES, AND LIKE SANITARY APPLIANCES.	26, Closets, urinals, baths, lavatories, and like sanitary appliances.	I.
27, COIN-FREED APPARATUS AND THE LIKE ...	27, Coin-freed apparatus and the like ...	XVIII.
28, COOKING AND KITCHEN APPLIANCES, BREAD-MAKING AND CONFECTIONERY.	{ 28 (i), Bread-making, confectionery, and cooking-appliances. 28 (ii), Kitchen and like appliances other than cooking-appliances.	VI.
29, COOLING AND ICE-MAKING, (including Refrigerators and Ice-storing).	29, Cooling and ice-making, (including Refrigerators and Ice-storing).	XIII.
30, CUTLERY ...	30, Cutlery ...	XIV.
31, CUTTING, PUNCHING, AND PERFORATING PAPER, LEATHER, AND FABRICS, (including the general treatment of paper after its manufacture)	{ 31 (i), Cutting and severing machines for paper, leather, fabrics, and the like. 31 (ii), Punching and perforating machines and hand tools for cutting, punching, perforating, and tearing paper, leather, fabrics, and the like.	VIII.
32, DISTILLING, CONCENTRATING, EVAPORATING AND CONDENSING LIQUIDS, (excepting Steam-engine condensers).	32, Distilling and evaporating liquids, (including Condensing vapours and Crystallizing).	III.
33, DRAINS AND SEWERS ...	33, Drains and sewers ...	I.
34, DRYING ...	{ 34 (i), Drying gases, clothes, and materials in long lengths ... 34 (ii), Drying systems and apparatus, (other than Drying gases, clothes, and materials in long lengths).	XIII.
35, DYNAMO-ELECTRIC GENERATORS AND MOTORS, (including Frictional and influence machines, magnets, and the like).	35, Dynamo-electric generators and motors, (including Frictional and influence machines, magnets, and the like).	XXXV.
36, ELECTRICITY, CONDUCTING AND INSULATING	36, Electricity, Conducting and insulating (1909-15 out of print.)	XXXVI.
37, ELECTRICITY, MEASURING AND TESTING ...	37, Electricity, Measuring and testing, (including Electric resistances and inductances). (1909-15 out of print.)	XXXVI.
	{ 38 (i), Electric couplings, and cut-outs other than electro-magnetic and thermal. 38 (ii), Electric currents. Converting and transforming other than by rotary converters and rotary transformers, and condensers. (1909-15 out of print.)	XXXV.
38, ELECTRICITY, REGULATING AND DISTRIBUTING.	{ 38 (iii), Electric motor control systems and motor and like controllers. (1909-15 out of print.) 38 (iv), Electric supply and transmission systems and apparatus not otherwise provided for. 38 (v), Electric switches and electro-magnetic and thermal cut-outs, (other than Motor and like controllers).	XXXVII.
	{ 39 (i), Electric lamps, Arc and incandescent-arc and vacuum or low-pressure apparatus for electric discharges through gases or vapours. 39 (ii), Electric lamps, Incandescent 39 (iii), Heating by electricity, (including Electric furnaces and ovens). (1909-15 out of print.)	XL.
39, ELECTRIC LAMPS AND FURNACES ...		XI.

List of Classes—Series (A) (1855–1908).	Corresponding Classes—Series (B) (1909–1930).	Corresponding Group Volume —Series (C) (1931 onwards).
40, ELECTRIC TELEGRAPHS AND TELEPHONES. (1884–8 out of print.)	40 (i), Electric signalling systems and apparatus ( <i>other than</i> Telegraphs and Telephones). 40 (ii), Phonographs, gramophones, and like sound record- ing and reproducing instruments. 40 (iii), Telegraphs, Electric ... .. 40 (iv), Telephones and telephone systems and apparatus, Electric. 40 (v), Wireless signalling and controlling. (1909–15 out of print.)	XXXVIII. XL. XXXIX. XL.
41, ELECTROLYSIS, ( <i>including</i> Electro-deposition and Electroplating).	41, Electrolysis, ( <i>including</i> Electro-deposition and Electro- plating). (1909–15 out of print.)	XXXVI.
42, FABRICS, DRESSING AND FINISHING WOVEN AND MANUFACTURING FELTED, ( <i>including</i> Folding, Winding, Measuring, and Packing).	42 (i), Fabrics, Finishing and dressing. 42 (ii), Fabrics, Treating otherwise than by finishing and dressing.	VIII.
43, FASTENINGS, DRESS, ( <i>including</i> Jewellery)....	43, Fastenings, Dress, ( <i>comprising</i> Buckles, Buttons, Jewellery, and certain other fastenings specially applicable to wearing apparel).	VII.
44, FASTENINGS, LOCK, LATCH, BOLT, AND OTHER ( <i>including</i> Safes and strong-rooms).	44, Fastenings, Lock, latch, bolt, and other, ( <i>including</i> Safes and strong-rooms).	XXV.
45, FENCING, TRELLIS, AND WIRE NETTING ...	45, Fencing, trellis, and wire netting ... ..	I.
46, FILTERING AND OTHERWISE PURIFYING LIQUIDS.	46, Filtering and otherwise purifying liquids ... ..	I.
47, FIRE, EXTINCTION AND PREVENTION OF ...	47 (i), Fire-escapes and fire and temperature alarms	XXI.
48, FISH AND FISHING ... ..	47 (ii), Fire-extinguishing and fire preventing and minimizing	XXI.
49, FOOD PREPARATIONS AND FOOD-PRESERVING	48, Fish and fishing ... ..	VI.
50, FUEL, MANUFACTURE OF ... ..	49, Food preparations, food preserving and the like ... ..	VII.
51, FURNACES AND KILNS, ( <i>including</i> Blowpipes and blowpipe burners; Smiths' forges and rivet hearths; and Smoke and fumes, Treating).	50, Fuel, Manufacture of ... .. 51 (i), Furnaces and kilns, Combustion apparatus of, ( <i>in- cluding</i> Details in connection therewith). 51 (ii), Furnaces and kilns for applying and utilizing heat of combustion, ( <i>other than</i> Combustion apparatus and details in connection therewith).	XII. XII.
52, FURNITURE AND UPHOLSTERY ... ..	52 (i), Furniture, Fittings and details applicable generally to, and articles of furniture not otherwise provided for. 52 (ii), Furniture for sitting and lying upon ... .. 52 (iii), Tables, desks, and leaf turners and holders ... .. 52 (iv), Upholstery, wall furniture, screens, and looking- glasses. 52 (v), Window, stair, and like furniture, brackets, racks, and stands, ( <i>including</i> Antimacassars and Table and like covers).	XIV.
53, GALVANIC BATTERIES ... ..	53, Galvanic batteries ... ..	XXXVI.
54, GAS DISTRIBUTION ... ..	54, Gas distribution ... ..	XXIX.
55, GAS MANUFACTURE ... ..	55 (i), Coking and gas-producers ... ..	XII.
56, GLASS ... ..	55 (ii), Gas manufacture other than gas-producers and retorts	XXIII.
57, GOVERNORS, SPEED-REGULATING, FOR EN- GINES AND MACHINERY.	56, Glass ... ..	XXVI.
58, GRAIN AND SEEDS, TREATING, ( <i>including</i> Flour and meal).	57, Governors, Speed-regulating, for engines and machinery...	I.
59, GRINDING, CRUSHING, PULVERIZING, AND THE LIKE.	58, Grain and seeds, Treating, ( <i>including</i> Flour and meal) ...	II.
60, GRINDING OR ABRADING, AND BURNISHING ...	59, Grinding, crushing, pulverizing, and the like ... ..	XXIII.
61, HAND TOOLS AND BENCHES FOR THE USE OF METAL, WOOD, AND STONE WORKERS.	60, Grinding or abrading, and burnishing ... .. 61 (i), Hand-tool, brush, mop, and like handles ... .. 61 (ii), Hand tools, ( <i>other than</i> Wrenches and bolt, nail, screw, and like inserting and extracting tools and Boring and drilling tools).	XXIII.
62, HARNESS AND SADDLERY ... ..	61 (iii), Wrenches and bolt, nail, screw, and like inserting and extracting tools.	I.
63, HATS AND OTHER HEAD COVERINGS ... ..	62, Harness and saddlery ... ..	VII.
64, HEATING, ( <i>excepting</i> Furnaces and kilns; and Stoves, ranges and fireplaces).	63, Hats and other head coverings ... ..	XIII.
65, HINGES, HINGE-JOINTS, AND DOOR AND GATE FURNITURE AND ACCESSORIES, ( <i>excepting</i> Fastenings, Lock, latch, bolt, and other).	64 (i), Heating liquids and gases. 64 (ii), Heating systems and apparatus, ( <i>other than</i> Heating liquids and gases and Surface apparatus for effecting trans- fer of heat). 64 (iii), Surface apparatus for effecting transfer of heat, ( <i>other than</i> Apparatus in which the heat is transferred from products of combustion).	XXV.
66, HOLLOW-WARE, ( <i>including</i> Buckets, Pans, Kettles, Saucepans, and Water-cans).	65 (i), Door and gate operating-appliances, furniture and accessories, ( <i>other than</i> Fastenings, Lock, latch, bolt, and other and Hinges and pivots)	XVII.
67, HORSESHOES ... ..	65 (ii), Hinges and pivots.	I.
68, HYDRAULIC ENGINEERING ... ..	66, Hollow-ware, ( <i>including</i> Buckets, Pans, Kettles, Sauce- pans, and Water cans) ... ..	XXI.
69, HYDRAULIC MACHINERY AND APPARATUS, ( <i>excepting</i> Pumps and other means for raising and forcing liquids).	67, Horseshoes ... ..	XXIX.
70, INDIA-RUBBER AND GUTTA-PERCHA, ( <i>including</i> Plastic compositions and Materials of con- structive utility, other than metals and stone).	68 (i), Excavating earth and rock, booms, buoys, canals and rivers, ferries, and water supply. 68 (ii), Subaqueous buildings and structures, diving, and raising sunken ships and objects. 69 (i), Hydraulic apparatus not otherwise provided for ... .. 69 (ii), Hydraulic presses, meters, motors, and like apparatus for use with high pressures. 69 (iii), Spray-producers and liquid-distributing sprinklers and nozzles.	V.



List of Classes—Series (A)  
(1855–1908).

Corresponding Classes—Series (B)  
(1909–1930).

Corresponding Group Volume—Series (C)  
(1931 onwards).

71, INJECTORS AND EJECTORS ... ..	71, Injectors and ejectors ... ..	XXVIII.
72, IRON AND STEEL MANUFACTURE ... ..	72, Iron and steel manufacture ... ..	II.
73, LABELS, BADGES, COINS, TOKENS, AND TICKETS.	73, Labels, badges, coins, tokens, and tickets ... ..	XV.
74, LACE-MAKING, KNITTING, NETTING, BRAIDING, AND PLAITING.	74 (i), Braid and braiding-machines, crochet, lace and lace-making, and net-making machines... ..	VIII.
	74 (ii), Knitting and knitted fabrics.	
75, LAMPS, CANDLESTICKS, GASALIERES, AND OTHER ILLUMINATING-APPARATUS, (excepting Electric lamps).	75 (i), Burners and burner fittings.	XI.
	75 (ii), Lamp chimneys, globes, lenses, shades, reflectors and smut-catchers, and holders therefor.	
	75 (iii), Lamps for lighting and heating, Details and accessories applicable generally to, (including Lighting burners, pipes, cigars, and the like).	
76, LEATHER, (including Treatment of hides and skins).	75 (iv), Lamps for lighting and heating, Kinds or types of, (including Lighting, Systems of).	VIII.
77, LIFE-SAVING, (MARINE), AND SWIMMING AND BATHING APPLIANCES.	76, Leather, (including Treatment of hides and skins) ...	
	77, Life-saving, (Marine), and swimming and bathing appliances.	XXI.
78, LIFTING, HAULING, AND LOADING, (including Lowering, winding, and unloading).	78 (i), Conveyors and elevators for dealing continuously with articles and materials in bulk.	XXX.
	78 (ii), Lifting, lowering, and hauling not otherwise provided for.	
	78 (iii), Lifts, hoists, and jacks.	
	78 (iv), Loading and unloading, (including Transporters and cranes).	
	78 (v), Winding and paying-out apparatus for lifting, lowering, and hauling, (including Pulley-blocks and the like).	
79, LOCOMOTIVES AND MOTOR VEHICLES FOR ROAD AND RAIL, (including Portable and semi-portable engines).	79 (i), Locomotives and tramway, traction, portable and semi-portable engines.	XXXI.
	79 (ii), Motor-vehicles, Arrangement and disposition of driving, transmission, balance, and reversing gearing on.	
	79 (iii), Motor vehicles, Arrangement and disposition of parts of, not otherwise provided for, (including Construction of parts peculiar to motor vehicles).	
	79 (iv), Motor vehicles, Frames and under-carriage work of.	
	79 (v), Motor vehicles and locomotives, Steering and controlling.	
80, MECHANISM AND MILL GEARING. (1877–1883 out of print).	80 (i), Gearing, Belt, rope, chain, toothed and friction, and gearing for converting and conveying rotary or reciprocating motion.	XXIV.
	80 (ii), Gearing, Variable-speed, differential, and reversing, and for stopping and starting, and shafting and its accessories.	
	80 (iii), Link-work, cams and tappets, and ratchet and screw-and nut gearing.	
	80 (iv), Mechanism not otherwise provided for	
81, MEDICINE, SURGERY, AND DENTISTRY ...	81 (i), Disinfecting and deodorizing, and medical and like preparations.	VI.
	81 (ii), Medical, surgical, and dental appliances.	
82, METALS AND ALLOYS, [excepting Iron and Steel manufacture].	82 (i), Metals, Extracting and refining, and alloys.	II.
	82 (ii), Washing granular, powdered, and like materials, and amalgamating, cleaning, coating, and granulating metals.	
83, METALS, CUTTING AND WORKING ... ..	83 (i), Casting and moulding metals.	XXII.
	83 (ii), Metal articles and forms, Combination apparatus and processes specially designed for producing and treating.	
	83 (iii), Metals, Cutting.	
	83 (iv), Metals, Working.	
84, MILKING, CHURNING, AND CHEESE-MAKING ...	84, Milking, butter-making, and cheese-making ... ..	I.
85, MINING, QUARRYING, TUNNELLING, AND WELL SINKING.	85, Mining, quarrying, tunnelling, and well-sinking ... ..	XXI.
86, MIXING AND AGITATING MACHINES AND APPLIANCES, [excepting Centrifugal machines and apparatus].	86, Mixing and agitating machines and appliances ... ..	II.
87, MOULDING PLASTIC AND POWDERED SUBSTANCES, (including Bricks, building and paving blocks, and tiles, and Pottery).	87 (i), Bricks, building and paving blocks, slabs, tiles, and pottery.	X.
	87 (ii), Moulding plastic and powdered substances, (including Casting substances other than metals and Presses, (Mechanical)).	V.
88, MUSIC AND MUSICAL INSTRUMENTS ... ..	88 (i), Musical instruments, Automatic.	XXXVIII
	88 (ii), Music and musical instruments other than automatic.	
89, NAILS, RIVETS, BOLTS AND NUTS, SCREWS AND LIKE FASTENINGS.	89 (i), Bolts, studs, nuts, washers, and rivets.	XXV.
	89 (ii), Hooks, nails, cotters, pins, staples, wedges, and wood-screws.	
	89 (iii), Nailing and stapling and wire-stitching ... ..	
90, NON-METALLIC ELEMENTS ... ..	90, Non-metallic elements ... ..	VII.
91, OILS, FATS, LUBRICANTS, CANDLES, AND SOAPS	91, Oils, fats, lubricants, candles, and soaps. (1909–15 out of print.)	III.
92, ORDNANCE AND MACHINE GUNS ... ..	92 (i), Ordnance and machine-gun carriages and mountings.	XXI.
	92 (ii), Ordnance and machine-guns ... ..	
93, ORNAMENTS ... ..	93, Ornamenting ... ..	XV.
94, PACKING AND BALING GOODS ... ..	94 (i), Packing and wrapping-up for transit and storage, (including Baling).	XVII.
	94 (ii), Paper bags, sacks, wrappers, and the like, (including Making envelopes).	
95, PAINTS, COLOURS, AND VARNISHES ... ..	95, Paints, painting, and the like ... ..	III.
96, PAPER, PASTEBOARD, AND PAPIER MACHE ...	96, Paper, pasteboard, and papier mache ... ..	VIII.

List of Classes—Series (A) (1855–1908).	Corresponding Classes—Series (B) (1909–1930).	Corresponding Group Volume —Series (C) (1931 onwards).
97, PHILOSOPHICAL INSTRUMENTS, ( <i>including</i> Optical, nautical, surveying, mathematical, and meteorological instruments). (1877–83 <i>out of print.</i> ) ... ..	97 (i), Optical systems and apparatus. (1909–15 <i>out of print.</i> ) 97 (ii), Surveying, navigational, and astronomical instruments.	XX.
98, PHOTOGRAPHY ... ..	97 (iii), Thermometers, meteorological and mathematical instruments, and miscellaneous philosophical instruments. 98 (i), Photographic cameras and auxiliary apparatus therefor. 98 (ii), Photographic processes and apparatus other than for taking photographs. ( <i>including</i> Photographic plates, films, and papers).	XX.
99, PIPES, TUBES, AND HOSE ... ..	99 (i), Pipes and tubes, Joints and couplings for, ( <i>including</i> Joints for tubular framework <i>and like</i> Wire and rod couplings and joints). 99 (ii), Pipes, tubes, and hose, ( <i>other than</i> Joints and couplings for).	XXVIII.
100, PRINTING, LETTERPRESS AND LITHOGRAPHIC	100 (i), Feeding and delivering webs and sheets. 100 (ii), Printing processes and apparatus, ( <i>other than</i> Type setting and composing). 100 (iii), Type making, setting, and composing, ( <i>including</i> Type-bar-making machines). 100 (iv), Typewriters and like machines.	XVI.
101, PRINTING, OTHER THAN LETTERPRESS OR LITHOGRAPHIC.	101, Now included in 100 (ii).	
102, PUMPS AND OTHER MEANS FOR RAISING AND FORCING LIQUIDS, [ <i>excepting</i> Rotary Pumps].	102 (i), Pumps, Reciprocating, for liquids, ( <i>including</i> Steam-engine air-pumps <i>and</i> Combined pumps for liquids and gases). 102 (ii), Water and other liquids, and semi-liquids, Raising and forcing otherwise than by pumps.	XXVIII.
103, RAILWAY AND TRAMWAY VEHICLES ... ..	103 (i), Brakes and retarding apparatus ... .. 103 (ii), Rail and road vehicles, Details applicable generally to. 103 (iii), Railway and tramway vehicles, Accessories for. 103 (iv), Railway and tramway vehicles, Body details and kinds or types of. 103 (v), Railway and tramway vehicles, Draught, coupling, and buffing appliances for. 103 (vi), Railway and tramway vehicles. Undercarriage and underframe details of.	XXXIV. XXXII.
104, RAILWAYS AND TRAMWAYS ... ..	104 (i), Railway and tramway crossings and points and switches. 104 (ii), Railway and tramway permanent way other than crossings and points and switches, and railway and tramway systems other than electric. 104 (iii), Railways and tramways, Electric, ( <i>including</i> Electric traction).	XXX.
105, RAILWAY SIGNALS AND COMMUNICATING-APPARATUS.	105, Railway signals and communicating-apparatus ... ..	XXX.
106, REGISTERING, INDICATING, MEASURING AND CALCULATING, ( <i>excepting</i> Signalling and indicating by signals).	106 (i), Calculating, counting, and cash-registering apparatus. 106 (ii), Dynamometers, gauges, measures of length, steam-engine and like indicators, and testing-apparatus. 106 (iii), Fares and admission-fees checking, revolution and speed indicators, and odometers. 106 (iv), Indicating, recording, and registering apparatus not otherwise provided for. 106 (v), Measured quantities delivering, measures of capacity, and sampling liquids.	XIX. XVIII.
107, ROADS AND WAYS ... ..	107, Roads and ways ... ..	X.
108, ROAD VEHICLES ... ..	108 (i), Road vehicles, Body details and kinds or types of. 108 (ii), Road vehicles, Undercarriage details and draught appliances for.	XXXII.
109, ROPES AND CORDS ... ..	108 (iii), Springs and vibration-dampers ... .. 109, Ropes and cords ... ..	XXV.
110, ROTARY ENGINES, PUMPS, BLOWERS, EXHAUSTERS AND METERS. (1877–83 <i>out of print.</i> )	110 (i), Centrifugal and screw fans and pumps ... .. 110 (ii), Rotary engines, pumps, blowers, exhausters, and meters, ( <i>including</i> Rotary pump plant).	XXVI.
111, SEWAGE, TREATMENT OF, ( <i>including</i> Manure).	110 (iii), Turbines and reaction-wheels and motor power plant	
112, SEWING AND EMBROIDERING ... ..	111, Sewage, Treatment of, ( <i>including</i> Manure) ... .. 112, Sewing and embroidering ... ..	I. VII.
113, SHIPS, BOATS, AND RAFTS, DIV. I ... ..	113 (i), Ship and boat fittings and accessories, and pontoons and rafts. 113 (ii), Ships and boats, Kinds or types and structural details of.	XXXIII.
114, ————— DIV. II. ... ..	114, Ships, boats, and rafts, Propelling, steering, and manoeuvring.	XXXIII.
115, ————— DIV. III. ... ..	115, Ships, boats, and rafts, Rigging, sails, and spars for, ( <i>including</i> Boat raising, lowering, and disengaging gear).	XXXIII.
116, SHOP, PUBLIC-HOUSE, AND WAREHOUSE FITTINGS AND ACCESSORIES.	116, Shop, public-house, and warehouse fittings and accessories.	XVIII.
117, SIFTING AND SEPARATING ... ..	117, Sifting and separating ... ..	II.
118, SIGNALLING AND INDICATING BY SIGNALS, ( <i>excepting</i> Railway signals and communicating-apparatus).	118 (i), Indicators and burglar and like alarms ... .. 118 (ii), Signals, ( <i>including</i> Marine signals) ... ..	XXXVIII.
119, SMALL-ARMS ... ..	119, Small-arms ... ..	XXI.
120, SPINNING, ( <i>including</i> the preparation of fibrous materials <i>and</i> the doubling of yarns and threads).	120 (i), Spinning, Preparation of fibrous materials for, ( <i>including</i> Obtaining, opening, carding, and like treatment of fibres in general). 120 (ii), Spinning, twisting, and winding yarns and threads, ( <i>including</i> Winding cords, wire, and the like.) 120 (iii), Yarns and threads and miscellaneous spinning accessories and processes and treatment of fibres.	IX.



List of Classes—Series (A) (1855-1908).	Corresponding Classes—Series (B) (1909-1930).	Corresponding Group Volume —Series (C) (1931 onwards).
121, STARCH, GUM, SIZE, GLUE, AND OTHER STIFFENING AND ADHESIVE MATERIALS.	121, Starch, gum, size, glue, and other stiffening and adhesive materials.	V.
122, STEAM-ENGINES, (including Details common to fluid-pressure engines generally).	122 (i), Engine and like cylinders, connecting-rods, cross-heads and guides, fly-wheels, piston-rods, and pistons. 122 (ii), Steam-engine distributing and expansion valves and valve gear and valve-actuating arrangements therefor. 122 (iii), Steam-engines, Kinds or types of and details not otherwise provided for, (including Steam and other fluid-pressure hammers and presses. 122 (iv), Steam-engines, Regulating or controlling, starting, stopping, and reversing. 122 (v), Stuffing-boxes and substitutes therefor, (including Packing therefor).	XXVI.
123, STEAM GENERATORS, (excepting Furnaces)...	123 (i), Liquid-level regulating, indicating, and registering, incrustation and corrosion preventing and removing, and door lids and covers for resisting fluid pressure.	XVIII.
124, STONE, MARBLE, AND THE LIKE, CUTTING AND WORKING.	123 (ii), Steam-generators ... .. 123 (iii), Steam separators and superheaters ... .. 124, Stone, marble, and the like, Cutting and working... ..	XIII. XXIII.
125, STOPPERING AND BOTTLING, (including Bottles, jars, and like vessels).	125 (i), Bottles, jars, and like vessels, (including Non-refillable bottles, jars, and vessels). 125 (ii), Bottles, jars, and like vessels, Filling, opening, and closing, (other than Stoppers, lids, covers, and capsules). 125 (iii), Stoppers, lids, covers, and capsules, Bottle, jar, and like.	XVII.
126, STOVES, RANGES, AND FIREPLACES ... ..	126, Stoves, ranges, and fire-places ... ..	XI.
127, SUGAR ... ..	127, Sugar ... ..	VI.
128, TABLE ARTICLES AND APPLIANCES ... ..	128, Table articles and appliances ... ..	XIV.
129, TEA, COFFEE, COCOA, AND LIKE BEVERAGES	129, Tea, coffee, cocoa, and like beverages ... ..	VI.
130, TOBACCO ... ..	130, Tobacco ... ..	XIV.
131, TOILET AND HAIRDRESSING ARTICLES, AND PERFUMERY.	131, Toilet and hairdressing articles, and perfumery ... ..	XIV.
132, TOYS, GAMES, AND EXERCISES ... ..	132 (i), Amusement and exercising apparatus other than games and toys. 132 (ii), Games ... .. 132 (iii), Toys ... ..	XV.
133, TRUNKS, PORTMANTEAUX, HAND AND LIKE TRAVELLING BAGS, BASKETS, HAMPERS, AND OTHER WICKERWORK.	133, Trunks, portmanteaux, hand and like travelling bags, baskets, hampers, and other wickerwork	XVI
134, UMBRELLAS, PARASOLS, AND WALKING-STICKS.	134, Umbrellas, parasols, and walking-sticks ... ..	VII.
135, VALVES AND COCKS ... ..	135, Valves and cocks ... ..	XXIX.
136, VELOCIPEDES, (1877-83 out of print.) ... ..	136 (i), Cycle, velocipede, and like vehicle brakes, steering-mechanism, and miscellaneous accessories. 136 (ii), Cycle, velocipede, and like vehicle driving-mechanism, (including Human power driving mechanism for apparatus other than vehicles.) 136 (iii), Cycles, velocipedes, and like vehicles, Kinds or types and structural details of.	XXXI.
137, VENTILATION ... ..	137, Ventilation ... ..	X.
138, WASHING AND CLEANING CLOTHES, DOMESTIC ARTICLES, AND BUILDINGS.	138 (i), Washing and cleaning buildings and domestic articles other than clothes, and dry cleaning clothes and other absorbent materials. 138 (ii), Washing, mangling and wringing, ironing, and starching clothes.	XXIII. VIII.
139, WATCHES, CLOCKS, AND OTHER TIMEKEEPERS	139, Watches, clocks and other timekeepers ... ..	XVIII.
140, WATERPROOF AND SIMILAR FABRICS... ..	140, Waterproof and like fabrics ... ..	VIII.
141, WEARING-APPAREL ... ..	141, Wearing-apparel ... ..	VII.
142, WEAVING AND WOVEN FABRICS ... ..	142 (i), Looms, Driving, reversing, stopping, and starting, and loom-shedding mechanism and pattern cards, chains, surfaces, and the like. 142 (ii), Looms, Kinds or types of, and details not otherwise provided for. 142 (iii), Looms, Weft supplying, inserting, beating-up, cutting, doubling, and twisting-in. 142 (iv), Woven fabrics and articles, and warping, leasing, balling, and beaming yarns, (including Pile fabrics and Floor coverings).	IX.
143, WEIGHING-APPARATUS ... ..	143, Weighing-apparatus ... ..	XVIII.
144, WHEELS FOR VEHICLES, (excepting wheels for Locomotives and tramway and traction engines; Railway and tramway vehicles; and Toys). (1877-88; 1893-96; 1901-04 out of print.)	144 (i), Wheels for vehicles, (other than Wheel tyres, Pneumatic and other elastic, and rims for use therewith). 144 (ii), Wheel tyres, Pneumatic and other elastic and rims for use therewith.	XXXIV.
145, WOOD AND WOOD-WORKING MACHINERY.	145 (i), Wood, Cutting, (other than Sawing) ... .. 145 (ii), Wood, Working, (including Sawing) ... ..	XXIII.
146, WRITING-INSTRUMENTS AND STATIONERY, AND WRITING-ACCESSORIES, (including Educational appliances).	146 (i), Filing paper and like sheets. 146 (ii), Stationery, wafers and seals, educational appliances, and ciphers and codes. 146 (iii), Writing-instruments ink and receptacles for writing-materials.	XV.

To supplement the information relating to the Group volumes of Abridgments given in column 3 above, a full list of the 40 Groups showing the Classes in Series (B) covered by each Group is given below.

Group.	Corresponding Classes in Series B.
I. Agriculture. Fencing. Filtering. Sewage ...	5 (i-ii). 6 (i-iii). 26. 33. 45. 46. 58. 62. 67. 84. 111.
II. Metals and alloys. Mixing. Pulverizing. Separating	23. 59. 72. 82 (i-ii). 86. 117.
III. Chemistry, Inorganic. Distillation. Oils. Paints	1 (i-iii). 32. 90. 91. 95.
IV. Acetylene. Cellulose. Chemistry, Organic. Dyes and dyeing.	2 (i-iii). 15 (i-ii).
V. Cements. Indiarubber. Moulding, Non-metallic. Starch.	22. 70. 87 (ii). 121.
VI. Beverages. Food production. Medicine and surgery. Tobacco.	14 (i-ii). 28 (i-ii). 48. 49. 81 (i-ii). 127. 129. 130.
VII. Boots. Dress and dress fastenings. Nailing. Sewing.	17 (i-iii). 43. 63. 89 (iii). 112. 134. 141.
VIII. Fabrics (Finishing and Laundering). Knitting and Lace-making. Leather. Paper. Perforating and Severing Non-metallic Sheets. Waterproofing.	31 (i-ii). 42 (i-ii). 74 (i-ii). 76. 96. 138 (ii). 140.
IX. Spinning. Weaving ...	120 (i-iii). 142 (i-iv).
X. Buildings. Roads. Ventilation ...	20 (i-iv). 25. 87 (i). 107. 137.
XI. Electric heating. Lamps. Stoves ...	39 (ii-iii). 75 (i-iv). 126.
XII. Combustion furnaces. Fuel. Gas ...	50. 51 (i-ii). 55 (i-ii).
XIII. Cooling. Drying. Heating. Steam ...	29. 34 (i-ii). 64 (i-iii). 123 (ii-iii).
XIV. Cutlery. Furniture. Table and toilet articles ...	30. 52 (i-v). 128. 131.
XV. Books and stationery. Filing documents. Games. Ornamenting. Writing.	11. 16. 73. 93. 132 (i-iii). 146 (i-iii).
XVI. Printing. Typewriting ...	100 (i-iv).
XVII. Containers. Packing ...	18. 21. 66. 94 (i-ii). 125 (i-iii). 133.
XVIII. Advertising. Coin-freed apparatus. Horology. Measured quantities. Regulating liquids. Shop accessories. Weighing.	3 (i-ii). 27. 106 (v). 116. 123 (i). 139. 143.
XIX. Calculating. Registering ...	106 (i-iv).
XX. Photography. Scientific instruments ...	97 (i-iii). 98 (i-ii).
XXI. Excavating and mining. Fires, Fighting. Lifesaving. Subaqueous buildings. Warfare.	9 (i-ii). 47 (i-ii). 68 (i-ii). 77. 85. 92 (i-ii). 119.
XXII. Casting, cutting, and working metals ...	83 (i-iv).
XXIII. Abrading. Brushing and cleaning. Glass. Hand tools. Stone. Wood.	19. 56. 60. 61 (i-iii). 124. 138 (i). 145 (i-ii).
XXIV. Gearing ...	80 (i-iv).
XXV. Chains and ropes. Doors, Operating. Hinges. Locks and fastenings.	24. 44. 65 (i-ii). 89 (i-ii). 109.
XXVI. Centrifugal and rotary pumps. Governors. Steam engines. Turbines.	10. 57. 110 (i-iii). 122 (i-v).
XXVII. Internal-combustion, hot-air, and combustion-product engines.	7 (i-vi).
XXVIII. Compressing and conveying gases. Injectors. Pipes. Reciprocating pumps.	8 (i-ii). 71. 99 (i-ii). 102 (i-ii).
XXIX. Gas distribution. Hydraulic apparatus. Valves.	54. 69 (i-iii). 135.
XXX. Conveyors, Lifts. Railways. Railway signals ...	78 (i-v). 104 (i-iii). 105.
XXXI. Cycles. Motor vehicles ...	79 (i-v). 136 (i-iii).
XXXII. Rail and road vehicles. Springs ...	103 (ii-vi). 108 (i-iii).
XXXIII. Aircraft. Ships ...	4. 113 (i-ii). 114. 115.
XXXIV. Bearings. Brakes. Wheels ...	12 (i-iii). 103 (i). 144 (i-ii).
XXXV. Dynamo-electric machines. Electrical converters and transformers, supply and transmission systems.	35. 38 (ii). 38 (iv).
XXXVI. Electrical conduction, insulation, measurement, and testing. Electrolysis. Galvanic batteries.	36. 37. 38 (i). 41. 53.
XXXVII. Electric switches, switchgear, protective cut-out and motor control systems.	38 (iii). 38 (v).
XXXVIII. Music. Phonographs. Signals and alarms ...	13. 40 (i-ii). 88 (i-ii). 118 (i-ii).
XXXIX. Telephones ...	40 (iv).
XL. Arc lamps. Telegraphs and television. Thermionic valves. Wireless.	39 (i). 40 (iii). 40 (v).

## ABRIDGMENT CLASS AND INDEX KEY

Key to the Abridgment Classes and Groups and the Index Headings under which Specifications are classified.

Vol. I. 7s. 6d. (*Postage abroad extra*).

*Contents* :—Lists of Abridgment Classes arranged numerically and alphabetically, Table of Contents of Abridgment Classes, Consolidated List of Index Headings and main cross-references, arranged alphabetically.

Vol. II. 10s. (*Postage abroad extra*).

*Contents* :—Details of the subdivisions of each Index Heading and the cross-references thereunder. This volume is specially required for use with the Group Abridgment Volumes (Series C).

---

## FIFTY YEARS SUBJECT INDEX 1861—1910.

6d. *per volume*. (*Postage abroad extra*.)

A subject index of all published Complete Specifications of the years 1861—1910 classified in 271 volumes corresponding to series (B) of the Illustrated Abridgment Classes.

For a continuation of the "Fifty Years Subject Index" the searcher should consult the appropriate Abridgment Volumes and the subject-matter index published weekly in the Official Journal (Patents).

---

## GROUP ALLOTMENT INDEX TO ABRIDGMENTS OF SPECIFICATIONS

This Index specifies the Group volume in which Abridgments are published, and is issued after the publication of every 20,000 Specifications from 340,001 onwards. Three volumes are now on sale, dealing with Specifications Nos. 340,001—360,000, 360,001—380,000, and 380,001—400,000. Price per volume 1s. 0d. (inland); 1s. 2d. (abroad).

---

LONDON

Printed by HIS MAJESTY'S STATIONERY OFFICE PRESS, Pocock Street, S.E.1  
Published at the PATENT OFFICE, 25, Southampton Buildings, Chancery Lane, London, W.C.2  
1933



ULTIMHEAT<sup>®</sup>  
VIRTUAL MUSEUM





ULTIMHEAT®  
VIRTUAL MUSEUM